

ABBREVIATIONS USED IN THIS MANUAL

IN01H-0M

ATF	Automatic Transmission Fluid
B ₀	Overdrive Brake
B ₁	No.1 Brake
B ₂	No.2 Brake
B ₃	No.3 Brake
C ₀	Overdrive Direct Clutch
C ₁	Front Clutch
C ₂	Rear Clutch
D	Disc
F	Flange
F ₀	O/D One-way Clutch
F ₁	No.1 One-way Clutch
F ₂	No.2 One-way Clutch
MP	Multipurpose
O/D	Overdirve
P	Plate
SSM	Special Service Materials
SST	Special Service Tools

GLOSSARY OF SAE AND TOYOTA TERMS

This glossary lists all SAE-J1930 terms and abbreviations used in this manual in compliance with SAE^{IND16-02} recommendations, as well as their Toyota equivalents.

SAE ABBREVIATIONS	SAE TERMS	TOYOTA TERMS ()--ABBREVIATIONS
A/C	Air Conditioning	Air Conditioner
ACL	Air Cleaner	Air Cleaner
AIR	Secondary Air Injection	Air Injection (AI)
AP	Accelerator Pedal	-
B+	Battery Positive Voltage	+B, Battery Voltage
BARO	Barometric Pressure	-
CAC	Charge Air Cooler	Intercooler
CARB	Carburetor	Carburetor
CFI	Continuous Fuel Injection	-
CKP	Crankshaft Position	Crank Angle
CL	Closed Loop	Closed Loop
CMP	Camshaft Position	Cam Angle
CPP	Clutch Pedal Position	-
CTOX	Continuous Trap Oxidizer	-
CTP	Closed Throttle Position	-
DFI	Direct Fuel Injection (Diesel)	Direct Injection (DI)
DI	Distributor Ignition	-
DLC1	Data Link Connector 1	1: Check Connector
DLC2	Data Link Connector 2	2: Toyota Diagnosis Communication Link (TDCL)
DLC3	Data Link Connector 3	3: OBD II Diagnostic Connector
DTC	Diagnostic Trouble Code	Diagnostic Code
DTM	Diagnostic Test Mode	-
ECL	Engine Control Level	-
ECM	Engine Control Module	Engine ECU (Electronic Control Unit)
ECT	Engine Coolant Temperature	Coolant Temperature, Water Temperature (THW)
EEPROM	Electrically Erasable Programmable Read Only Memory	Electrically Erasable Programmable Read Only Memory (EEPROM), Erasable Programmable Read Only Memory (EPROM)
EFE	Early Fuel Evaporation	Cold Mixture Heater (CMH), Heat Control Valve (HCV)
EGR	Exhaust Gas Recirculation	Exhaust Gas Recirculation (EGR)
EI	Electronic Ignition	Toyota Distributorless Ignition (TDI)
EM	Engine Modification	Engine Modification (EM)
EPROM	Erasable Programmable Read Only Memory	Programmable Read Only Memory (PROM)
EVAP	Evaporative Emission	Evaporative Emission Control (EVAP)
FC	Fan Control	-
FEEPROM	Flash Electrically Erasable Programmable Read Only Memory	-
FEPROM	Flash Erasable Programmable Read Only Memory	-
FF	Flexible Fuel	-
FP	Fuel Pump	Fuel Pump
GEN	Generator	Alternator
GND	Ground	Ground (GND)
HO2S	Heated Oxygen Sensor	Heated Oxygen Sensor (HO2S)

INTRODUCTION - GLOSSARY OF SAE AND TOYOTA TERMS

IAC	Idle Air Control	Idle Speed Control (ISC)
IAT	Intake Air Temperature	Intake or Inlet Air Temperature
ICM	Ignition Control Module	-
IFI	Indirect Fuel Injection	Indirect Injection
IFS	Inertia Fuel-Shutoff	-
ISC	Idle Speed Control	-
KS	Knock Sensor	Knock Sensor
MAF	Mass Air Flow	Air Flow Meter
MAP	Manifold Absolute Pressure	Manifold Pressure Intake Vacuum
MC	Mixture Control	Electric Bleed Air Control Valve (EBCV) Mixture Control Valve (MCV) Electric Air Control Valve (EACV)
MDP	Manifold Differential Pressure	-
MFI	Multiport Fuel Injection	Electronic Fuel Injection (EFI)
MIL	Malfunction Indicator Lamp	Check Engine Light
MST	Manifold Surface Temperature	-
MVZ	Manifold Vacuum Zone	-
NVRAM	Non-Volatile Random Access Memory	-
O2S	Oxygen Sensor	Oxygen Sensor, O ₂ Sensor (O ₂ S)
OBD	On-Board Diagnostic	On-Board Diagnostic (OBD)
OC	Oxidation Catalytic Converter	Oxidation Catalyst Converter (OC), CCo
OP	Open Loop	Open Loop
PAIR	Pulsed Secondary Air Injection	Air Suction (AS)
PCM	Powertrain Control Module	-
PNP	Park/Neutral Position	-
PROM	Programmable Read Only Memory	-
PSP	Power Steering Pressure	-
PTOX	Periodic Trap Oxidizer	Diesel Particulate Filter (DPF) Diesel Particulate Trap (DPT)
RAM	Random Access Memory	Random Access Memory (RAM)
RM	Relay Module	-
ROM	Read Only Memory	Read Only Memory (ROM)
RPM	Engine Speed	Engine Speed
SC	Supercharger	Supercharger
SCB	Supercharger Bypass	-
SFI	Sequential Multiport Fuel Injection	Electronic Fuel Injection (EFI), Sequential Injection
SPL	Smoke Puff Limiter	-
SRI	Service Reminder Indicator	-
SRT	System Readiness Test	-
ST	Scan Tool	-
TB	Throttle Body	Throttle Body
TBI	Throttle Body Fuel Injection	Single Point Injection Central Fuel Injection (Ci)
TC	Turbocharger	Turbocharger
TCC	Torque Converter Clutch	Torque Converter
TCM	Transmission Control Module	Transmission ECU (Electronic Control Unit)
TP	Throttle Position	Throttle Position
TR	Transmission Range	-

IN-8

INTRODUCTION - GLOSSARY OF SAE AND TOYOTA TERMS

TVV	Thermal Vacuum Valve	Bimetallic Vacuum Switching Valve (BVSV) Thermostatic Vacuum Switching Valve (TVSV)
TWC	Three-Way Catalytic Converter	Three-Way Catalyst (TWC) CC _{RO}
TWC+OC	Three-Way + Oxidation Catalytic Converter	CC _R + CC _o
VAF	Volume Air Flow	Air Flow Meter
VR	Voltage Regulator	Voltage Regulator
VSS	Vehicle Speed Sensor	Vehicle Speed Sensor (Reed Switch Type)
WOT	Wide Open Throttle	Full Throttle
WU-OC	Warm Up Oxidation Catalytic Converter	-
WU-TWC	Warm Up Three-Way Catalytic Converter	Manifold Converter
3GR	Third Gear	-
4GR	Fourth Gear	-

HOW TO USE THIS MANUAL

To assist you in finding your way through the manual, the Section Title and major heading are given at the top of every page. IN032-0J

PREPARATION

Preparation lists the SST (Special Service Tools), recommended tools, equipment, lubricant and SSM (Special Service Materials) which should be prepared before beginning the operation and explains the purpose of each one.

REPAIR PROCEDURES

Most repair operations begin with an overview illustration. It identifies the components and shows how the parts fit together.

Example:

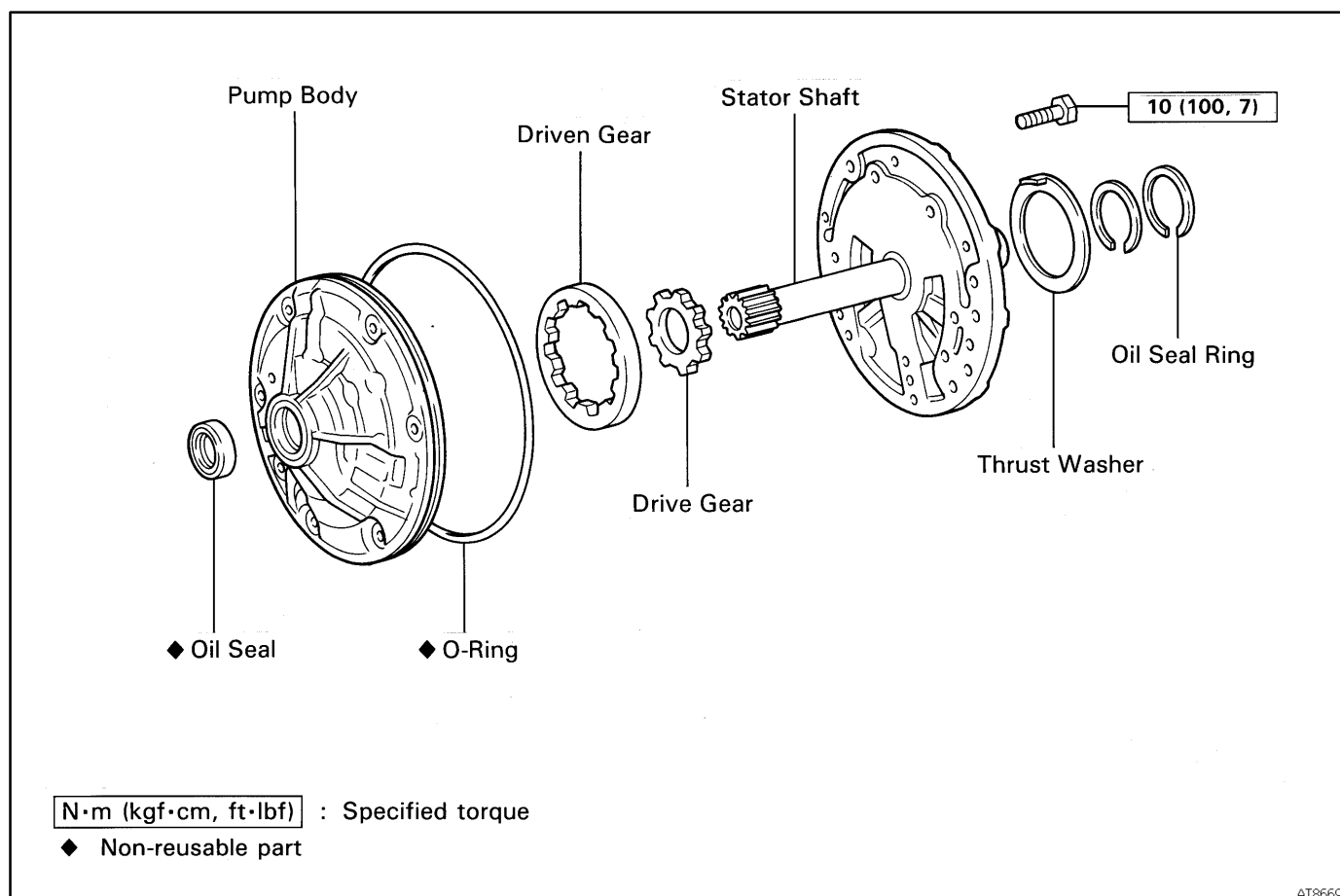

The procedures are presented in a step-by-step format:

- ★ The illustration shows what to do and where to do it.
- ★ The task heading tells what to do.
- ★ The detailed text tells how to perform the task and gives other information such as specifications and warnings.

Example:

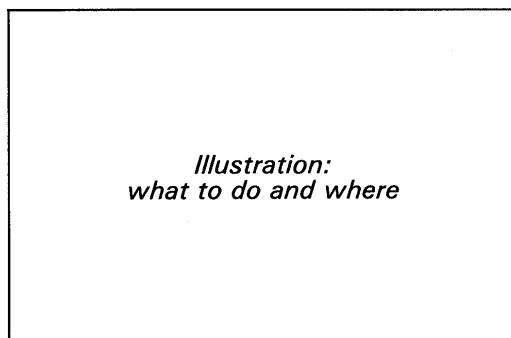

Task heading : what to do

21. CHECK PISTON STROKE OF OVERDRIVE BRAKE

(a) Place SST and a dial indicator onto the overdrive brake piston as shown in the illustration.

SST 09350-30020 (09350-06120)

Set part No. *Component part No.*

Detailed text: how to do task

(b) Measure the stroke applying and releasing the compressed air (392 – 785 kPa, 4 – 8 kgf/cm² or 57 – 114 psi) as shown in the illustration.

Piston stroke: 1.40 – 1.70 mm (0.0551 – 0.0669 in.)

Specification

V00081

This format provides the experienced technician with a FAST TRACK to the information needed. The upper case task heading can be read at a glance when necessary, and the text below it provides detailed information. Important specifications and warnings always stand out in bold type.

REFERENCES

References have been kept to a minimum. However, when they are required you are given the page to refer to.

SPECIFICATIONS

Specifications are presented in bold type throughout the text where needed. You never have to leave the procedure to look up your specifications. They are also found at the back of AT section, for quick reference.

CAUTIONS, NOTICES, HINTS:

- ★ CAUTIONS are presented in bold type, and indicate there is a possibility of injury to you or other people.
- ★ NOTICES are also presented in bold type, and indicate the possibility of damage to the components being repaired.
- ★ HINTS are separated from the text but do not appear in bold. They provide additional information to help you perform the repair efficiently.

SI UNIT

The UNITS given in this manual are primarily expressed according to the SI UNIT (International System of Unit), and alternately expressed in the metric system and in the English system.

Example:

Torque: 30 N·m (310 kgf·cm, 22 ft·lbf)

AT-2

AUTOMATIC TRANSMISSION - DESCRIPTION

DESCRIPTION

GENERAL

AT044-04

The A43D is a 4-speed automatic transmission.

The A43D automatic transmission is mainly composed of a torque converter clutch, a overdrive (hereafter called O/D) planetary gear unit, a 3-speed planetary gear unit and a hydraulic control system.

Sectional View

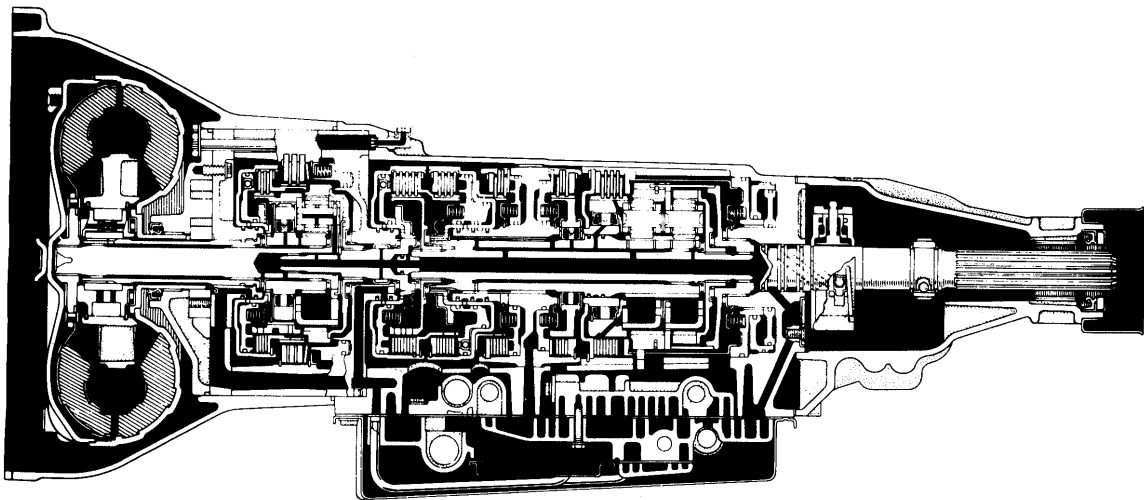

AT4220

GENERAL SPECIFICATIONS

Type of Transmission		A43D
Type of Engine		22R-E
Torque Converter Clutch Stall Torque Ratio		1.75 : 1
Lock-up Mechanism		Equipped
Gear Ratio	1st Gear	2.452
	2nd Gear	1.452
	3rd Gear	1.000
	O/D Gear	0.688
	Reverse Gear	2.212
Number of Discs and Plates	O/D Direct Clutch (C ₀)	1 / 0
	Forward Clutch (C ₁)	4 / 4
	Rear Clutch (C ₂)	3 / 3
	No.2 Brake (B ₂)	3 / 3
	No.3 Brake (B ₃)	5 / 4
	O/D Brake (B ₀)	3 / 3
	No.1 Brake (B ₁)	1 / 1
ATF Type		ATF DEXRON® II
Capacity (US qts, Imp.qts)	Total	6.3 (6.7, 5.5)
	Drain and Refill	2.4 (2.5, 2.1)

OPERATION

1. OPERATING CONDITIONS

AT0A5-02

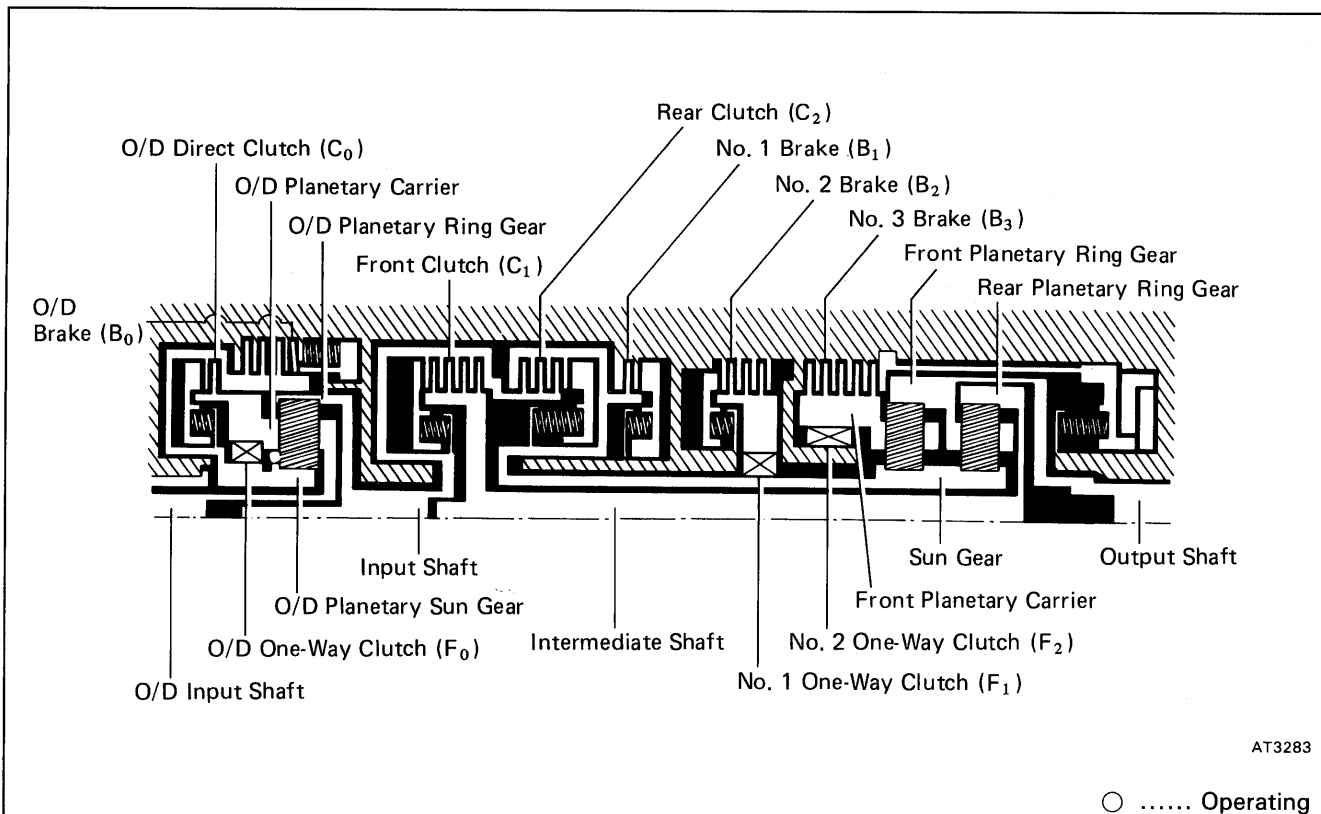

AT3283

○ Operating

Shift lever position	Gear position	C ₀	C ₁	C ₂		B ₀	B ₁	B ₂	B ₃		F ₀	F ₁	F ₂
				I.P.	O.P.				I.P.	O.P.			
P	Parking	○							○	○	○		
R	Reverse	○		○	○				○	○	○		
N	Neutral	○									○		
D	1st	○	○								○		○
	2nd	○	○					○			○	○	
	3rd	○	○		○			○			○		
	O/D		○		○	○		○					
2	1st	○	○								○		○
	2nd	○	○				○	○			○	○	
L	1st	○	○						○	○	○		○

I.P. Inner Piston
O.P. Outer Piston

2. FUNCTION OF COMPONENTS

COMPONENT	FUNCTION
O/D Direct Clutch (C ₀)	Connects overdrive sun gear and overdrive carrier
O/D Brake (B ₀)	Prevents overdrive sun gear from turning either clockwise or counterclockwise
O/D One-Way Clutch (F ₀)	When transmission is being driven by engine, connects overdrive sun gear and overdrive carrier
Front Clutch (C ₁)	Connects input shaft and intermediate shaft
Rear Clutch (C ₂)	Connects input shaft and front & rear planetary sun gear
No. 1 Brake (B ₁)	Prevents front & rear planetary sun gear from turning either clockwise or counterclockwise
No. 2 Brake (B ₂)	Prevents outer race of F ₁ from turning either clockwise or counterclockwise, thus preventing front & rear planetary sun gear from turning counterclockwise
No. 3 Brake (B ₃)	Prevents front planetary carrier from turning either clockwise or counterclockwise
No. 1 One-Way Clutch (F ₁)	When B ₂ is operating, prevents front & rear planetary sun gear from turning counterclockwise
No. 2 One-Way Clutch (F ₂)	Prevents front planetary carrier from turning counterclockwise

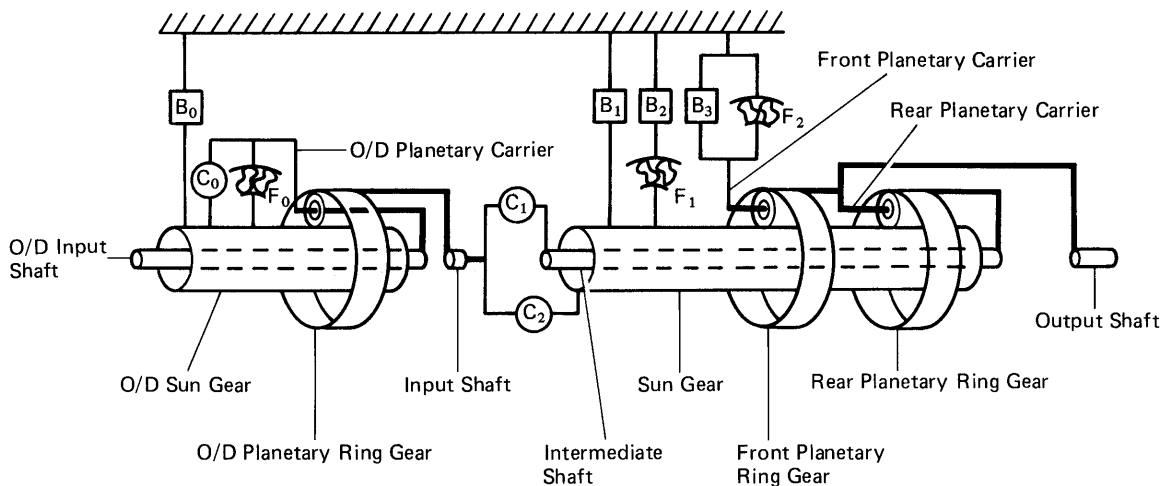

AT3282

The conditions of operation for each gear position are shown in the following illustrations:

D or 2 Position 1st Gear

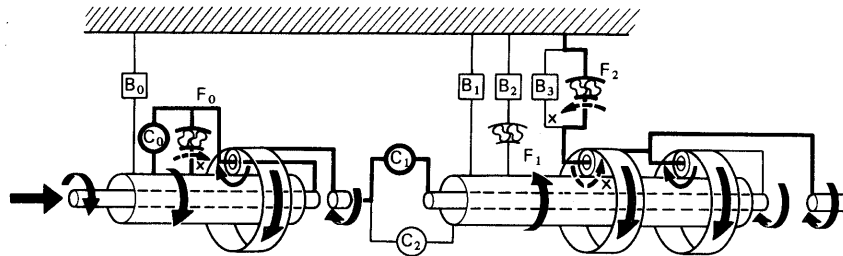

AT7802

D Position 2nd Gear

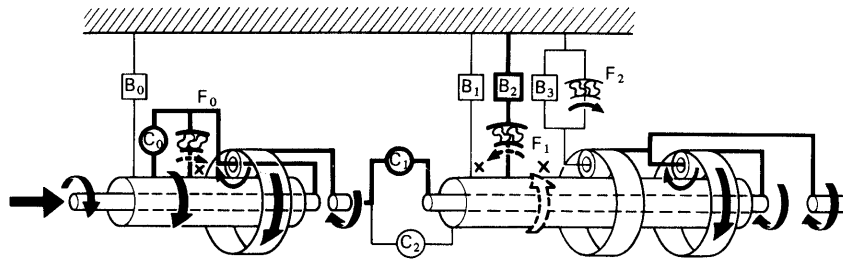

AT7803

D or 2 Position 3rd Gear

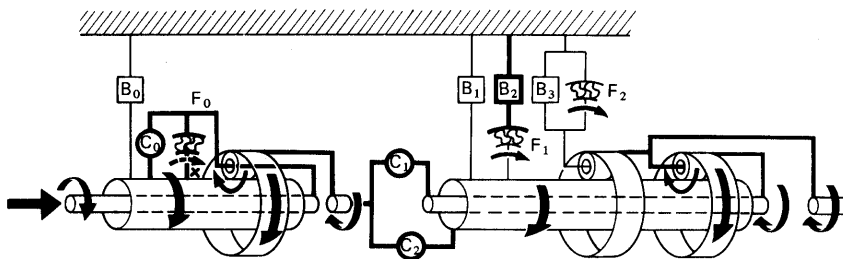

AT7804

D Position O/D

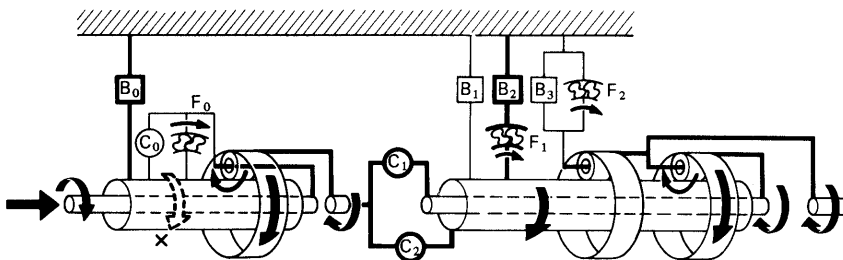

AT7805

2 or L Position 2nd Gear

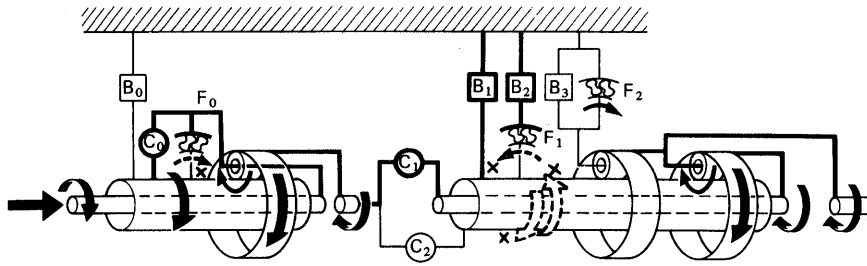

AT7806

L Position 1st Gear

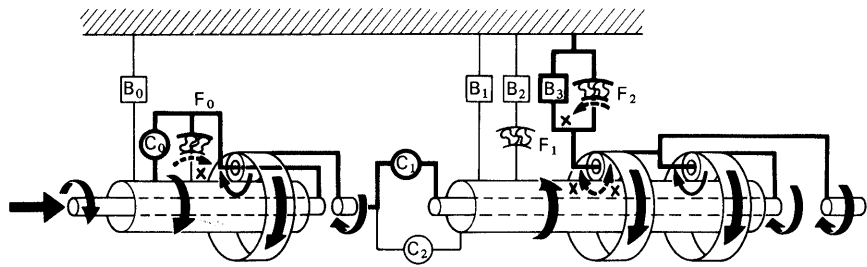

AT7807

R Position Reverse Gear

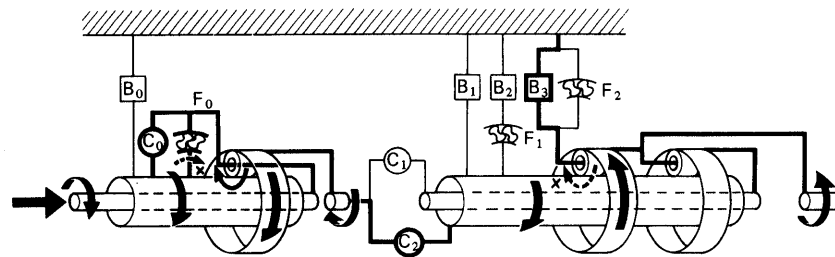

AT7808

3. HYDRAULIC CONTROL SYSTEM

The hydraulic control system is composed of the oil pump, the valve body, the governor body, the accumulators, the clutches and brakes as well as the fluid passage which connect all of these components. Based in the hydraulic pressure created by the oil pump, the hydraulic control system governs the hydraulic pressure acting on the torque converter, clutches and brakes in accordance with the vehicle driving conditions.

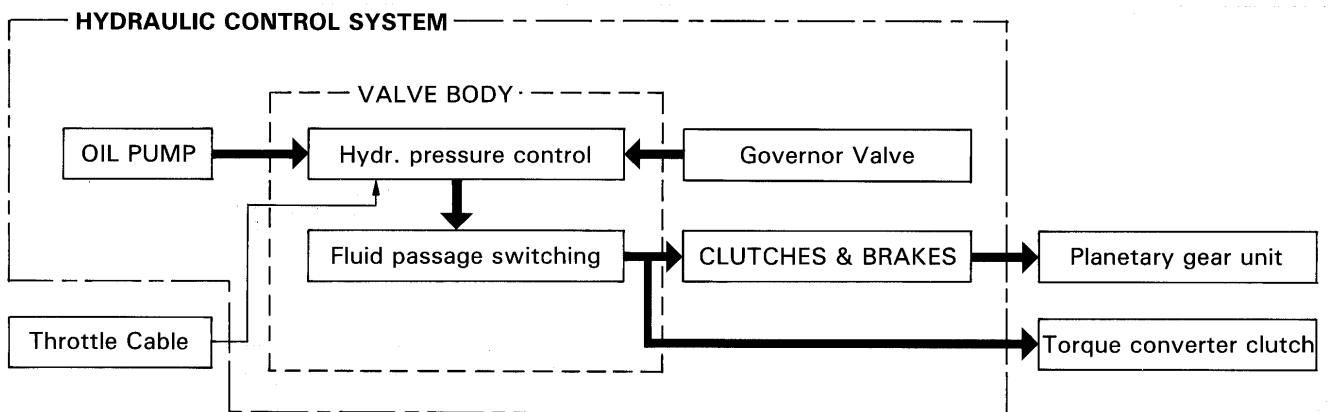





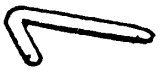

AT-10

AUTOMATIC TRANSMISSION - PREPARATION

PREPARATION SST (SPECIAL SERVICE TOOLS)

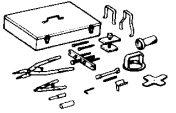
AT0A6-03

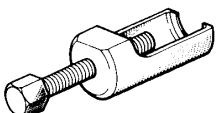
	<p>09350-20015 TOYOTA Automatic Transmission Tool Set</p>	
	<p>(09350-06120) No.2 Measure Terminal</p>	
	<p>(09361-3001 1) Manual Valve Lever Shaft Oil Seal Replacer</p>	
	<p>(09362-3001 1) Guide Bolt</p>	
	<p>(09369-20040) Piston Spring Compressor Set</p>	
	<p>(09370-12010) Clutch Drum Thrust Play Gauge</p>	
	<p>09350-30020 TOYOTA Automatic Transmission Tool Set</p>	
	<p>(09350-07080) Brake Reaction Sleeve Puller</p>	
	<p>(09350-07090) Brake No.1 Piston Puller</p>	
	<p>09610-20012 Pitman Arm Puller</p>	

AT0A7-02

RECOMMENDED TOOLS

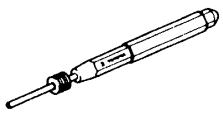
	<p>09031-00030 Pin Punch .</p>	
---	--------------------------------	--

EQUIPMENT

AT0A8-03

Feeler gauge	
Vernier calipers	
Dial indicator or dial indicator with magnetic base	
Dial indicator	
Straight edge	
Torque wrench	
Cylinder gauge	

LUBRICANT

AT0A9-03

Item	Capacity	Classification
Dry fill	6.3 liters (6.7 US qts, 5.5 Imp. qts)	ATF DEXRON® II
Drain and refill	2.4 liters (2.5 US qts, 2.1 Imp. qts)	

SSM (SPECIAL SERVICE MATERIALS)

AT0AA-03

08833-00080	Adhesive 1344, THREE BOND 1344, LOCTITE 242 or equivalent	Oil pump set bolt Extension housing set bolt
-------------	---	---

COMPONENT PARTS REMOVAL COMPONENTS

AT0AB-04

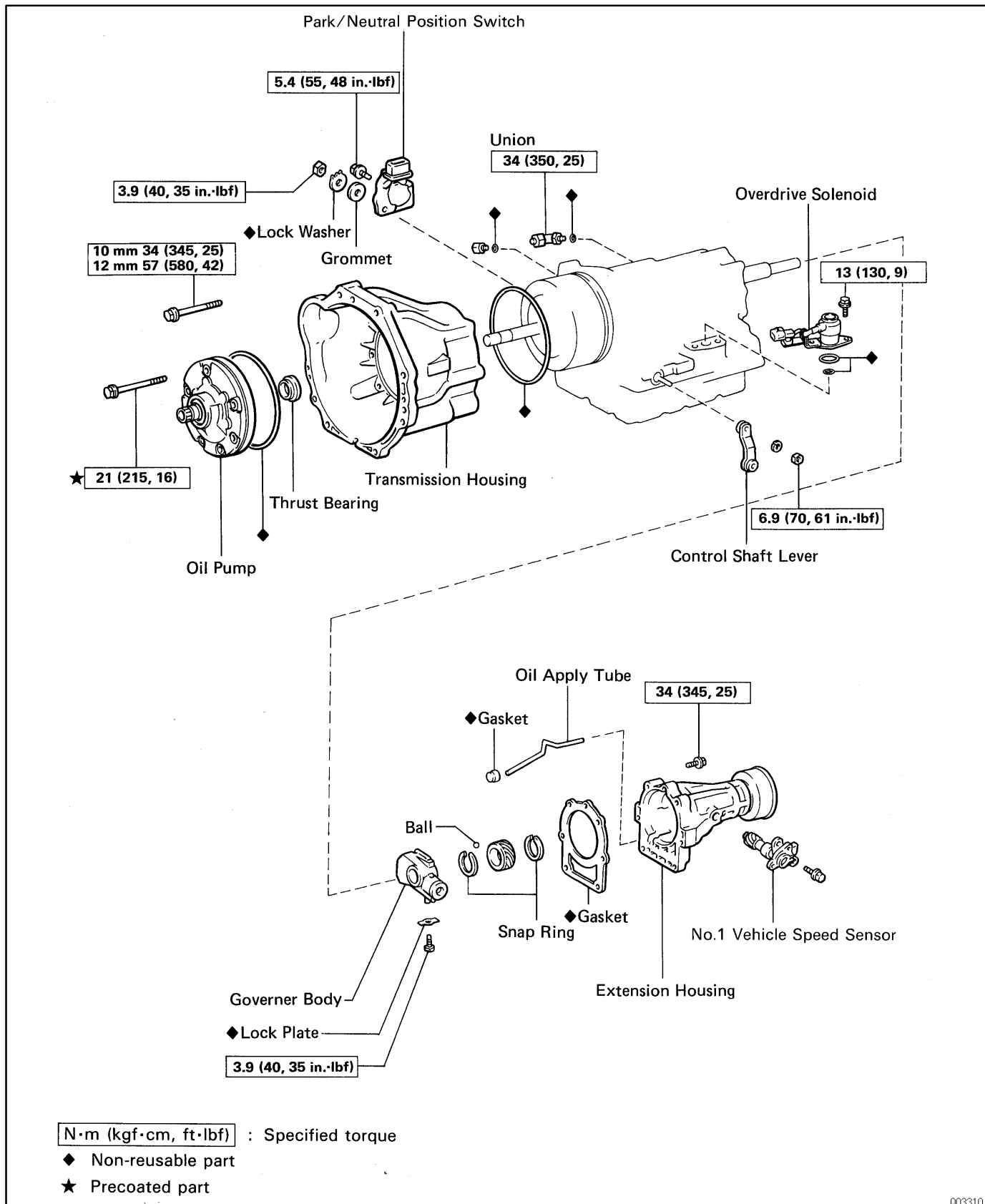

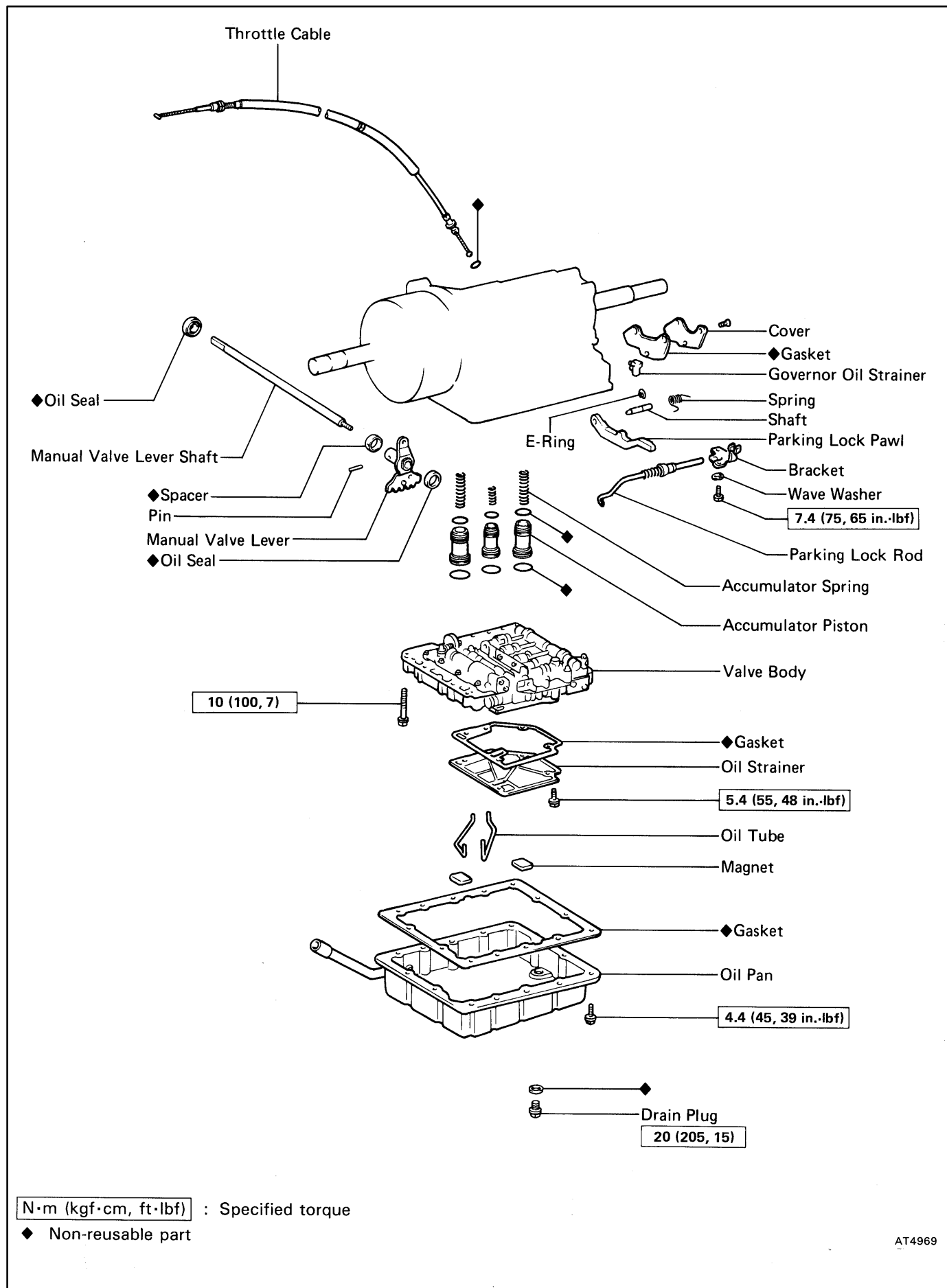

N·m (kgf·cm, ft·lbf) : Specified torque

◆ Non-reusable part

AUTOMATIC TRANSMISSION - COMPONENT PARTS REMOVAL

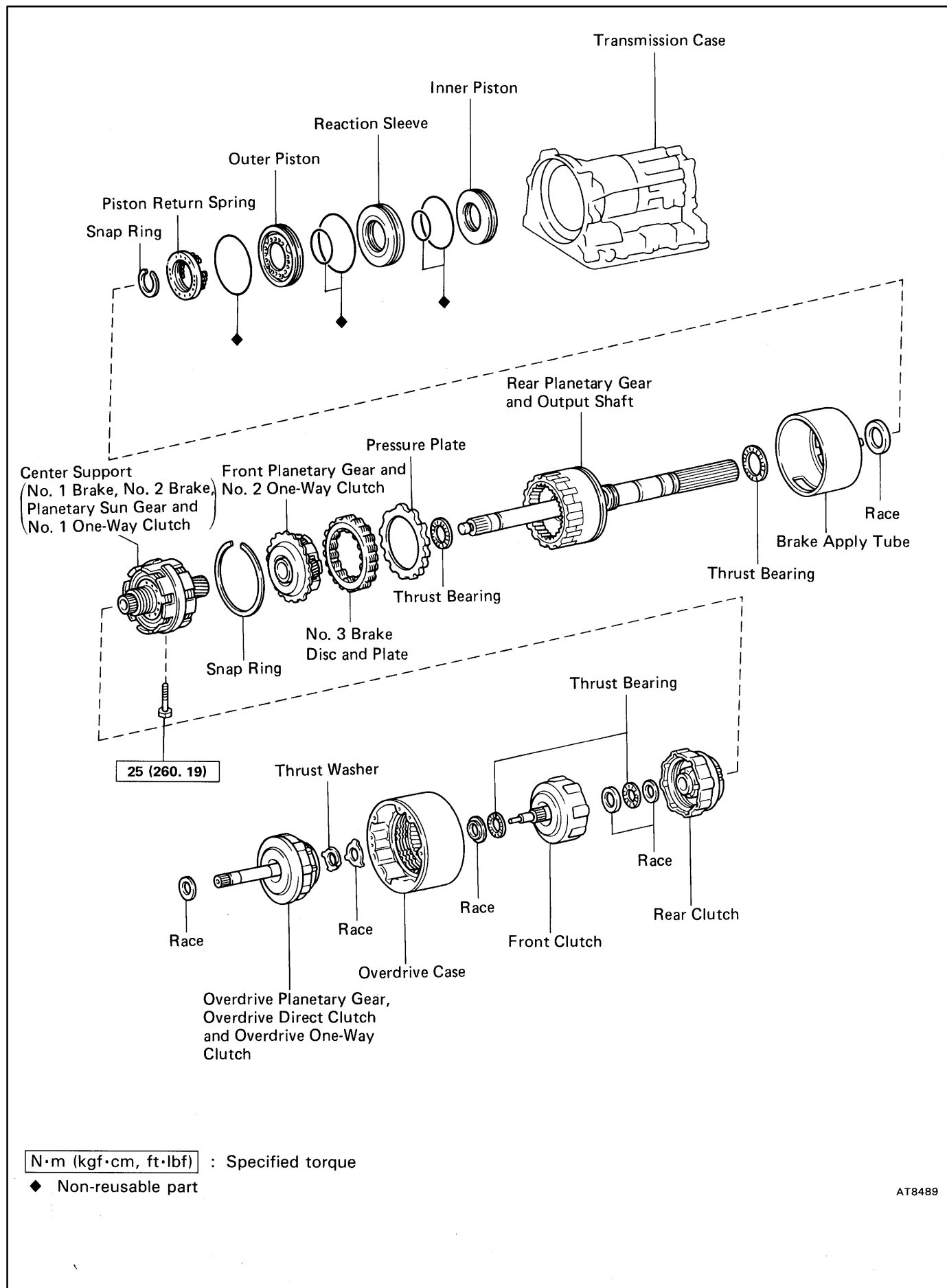

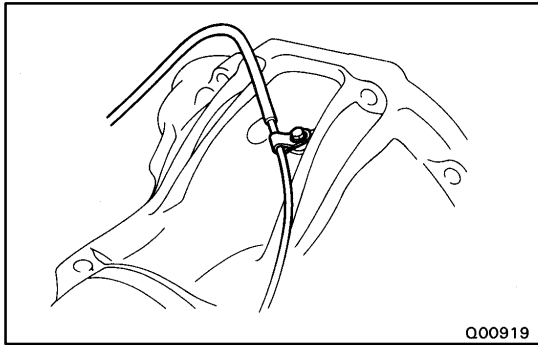

BASIC SUBASSEMBLY SEPARATION

1. REMOVE WIRE HARNESS CLAMP AND THROTTLE CABLE CLAMP

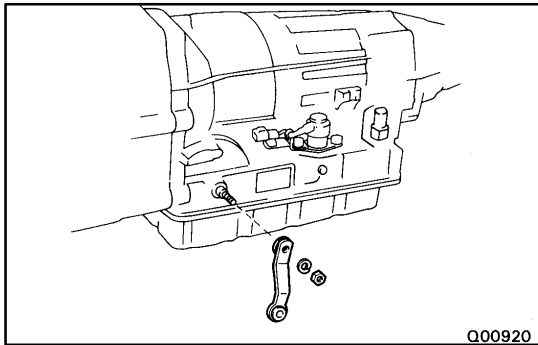

2. REMOVE CONTROL SHAFT LEVER

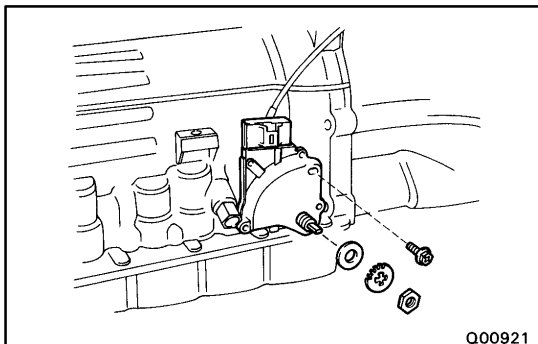

3. REMOVE PARK/NEUTRAL POSITION SWITCH

- (a) Unstake the lock washer.
- (b) Remove the nut and bolt.
- (c) Remove the lock washer and grommet.
- (d) Remove the park/neutral position switch.

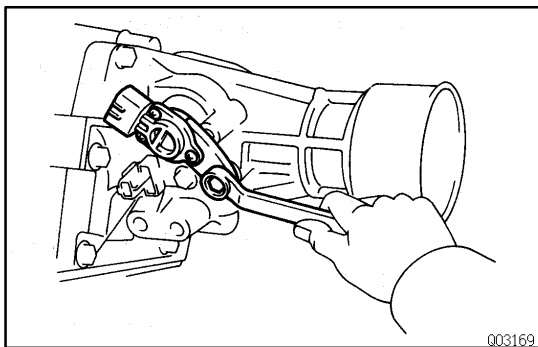

4. REMOVE NO.1 VEHICLE SPEED SENSOR

- (a) Remove the bolt and pull out the No.1 vehicle speed sensor.
- (b) Remove the O-ring from the sensor.

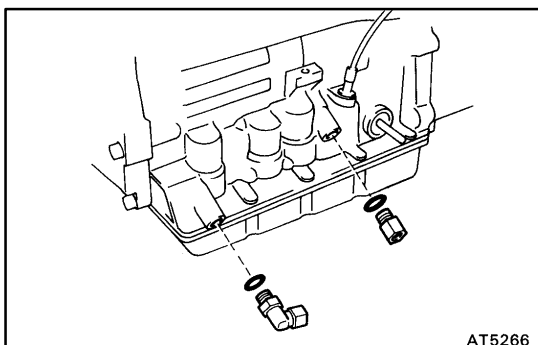

5. REMOVE UNIONS

- (a) Remove the 2 unions.
- (b) Remove the O-ring from both unions.

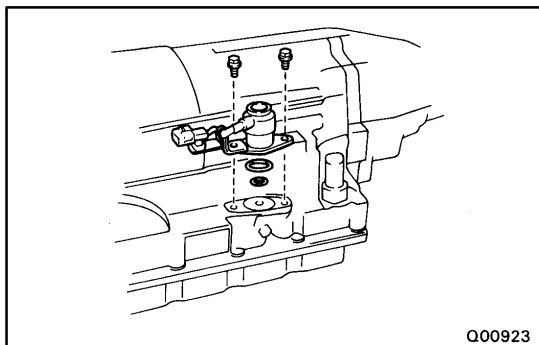

Q00923

6. REMOVE OVERDRIVE SOLENOID

- (a) Remove the 2 bolts and overdrive solenoid.
- (b) Remove the 2 O-rings.

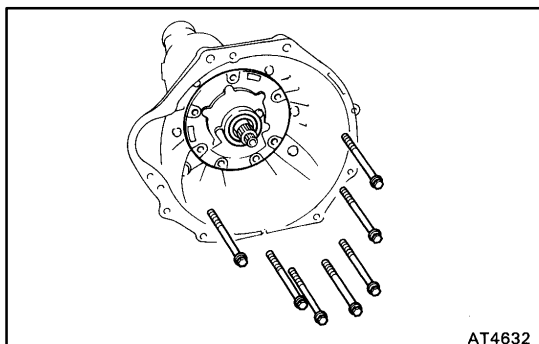

AT4632

7. REMOVE OIL PUMP

- (a) Remove the 7 bolts holding the oil pump to the transmission case.

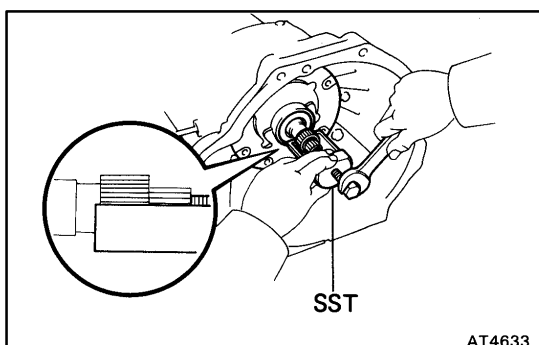

AT4633

- (b) Using SST, remove the oil pump.
SST 09610-20012

NOTICE: Do not damage the stator shaft bushing surface.

- (c) Remove the O-ring from it.

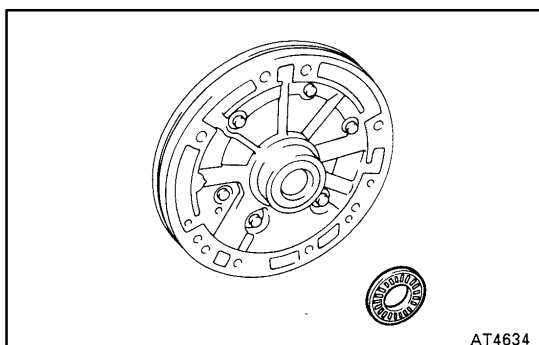

AT4634

- (d) Remove the assembled bearing and race from the oil pump rear side.

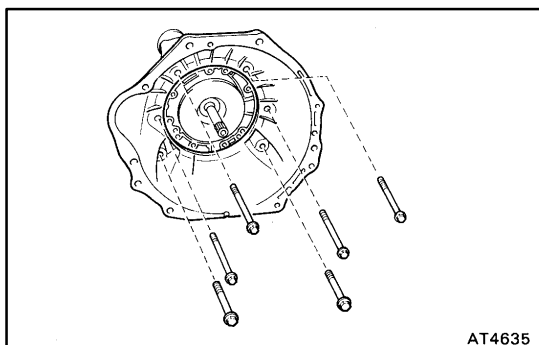

AT4635

8. REMOVE TRANSMISSION HOUSING

- (a) Remove the 6 bolts.
- (b) While holding the input shaft, remove the transmission housing.
- (c) Remove the O-ring from the overdrive case.

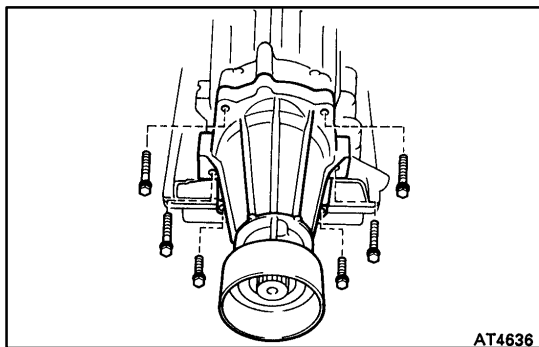

9. REMOVE EXTENSION HOUSING AND GASKET

- (a) Remove the 6 bolts.
- (b) Remove the extension housing and gasket.

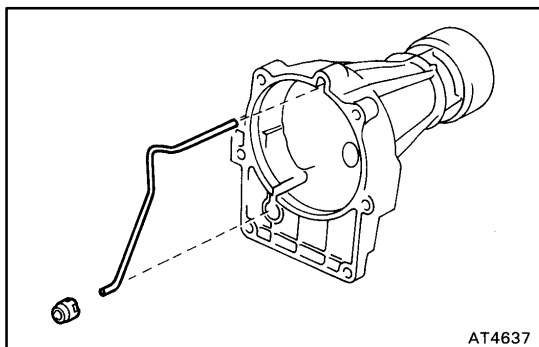

- (c) Remove the oil apply tube and gasket from the extension housing.

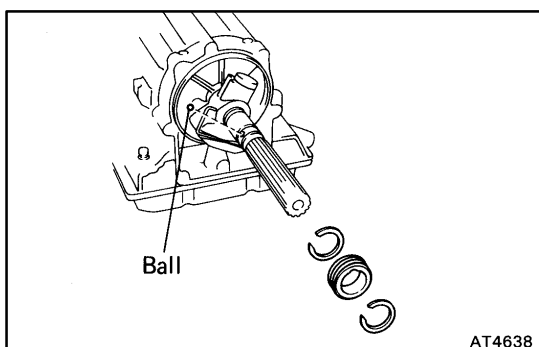

10. REMOVE VEHICLE SPEED SENSOR DRIVE GEAR AND BALL

- (a) Using a snap ring expander, remove the snap ring.
- (b) Remove the vehicle speed sensor drive gear and ball.
- (c) Using a snap ring expander, remove the snap ring.

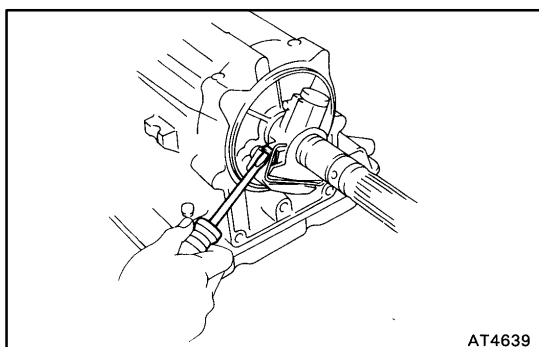

11. REMOVE GOVERNOR BODY

- (a) Using a screwdriver, loosen the staked part of the lock plate.
- (b) Remove the governor body lock bolt.

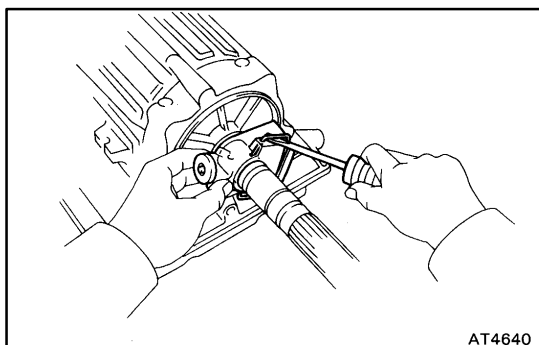

- (c) While lifting the retaining clip with a screwdriver, slide off the governor body.

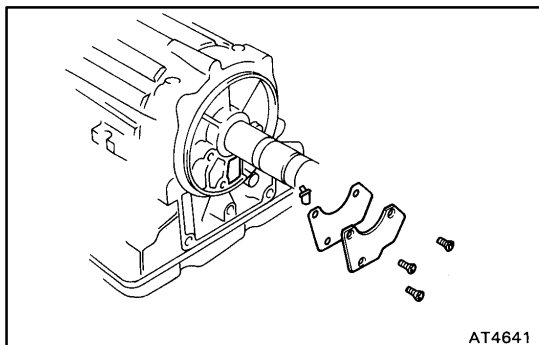

AT4641

12. REMOVE GOVERNOR OIL SEAL STRAINER

- (a) Remove the 3 screws, cover and gasket.
- (b) Remove the oil strainer from the transmission case.

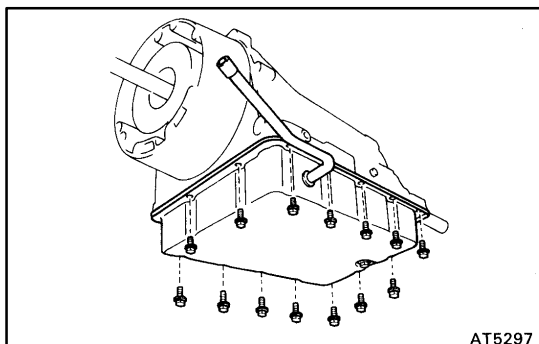

AT5297

13. REMOVE OIL PAN

NOTICE: Do not turn the transmission over as this will contaminate the valve body with any foreign matter at the bottom of the pan.

- (a) Remove the 14 bolts.
- (b) Remove the oil pan with lifting the transmission case.
- (c) Remove the oil pan gasket.

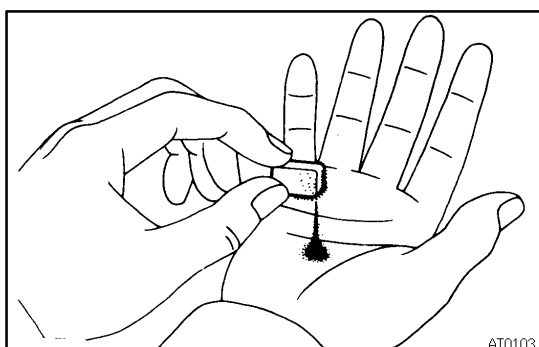

AT0103

14. EXAMINE PARTICLES IN PAN

Remove the magnets and use them to collect steel particles.

Carefully look at the foreign matter and particles in the pan and on the magnets to anticipate the type of wear you will find in the transmission:

Steel (magnetic) bearing, gear and clutch plate wear

Brass (non-magnetic) ... bushing wear

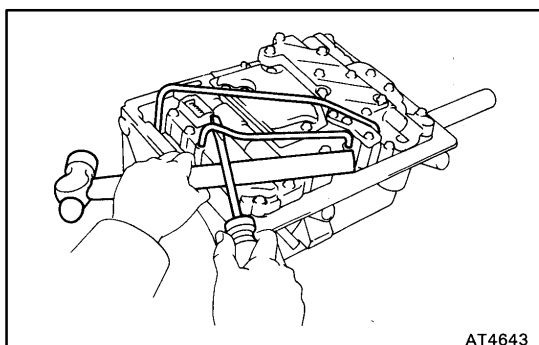

AT4643

15. REMOVE OIL TUBE

- (a) Turn over the transmission.
- (b) Pry up both tube ends with a large screwdriver and remove the 2 tubes.

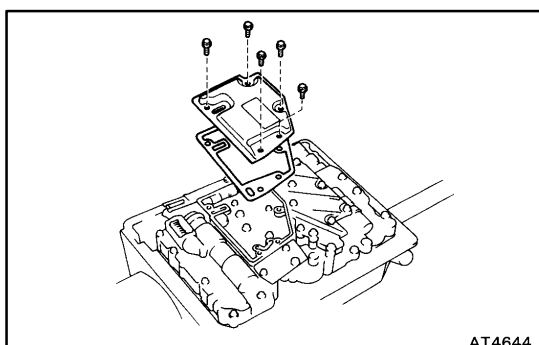

AT4644

16. REMOVE OIL STRAINER AND GASKET

- (a) Remove the 5 bolts holding the oil strainer to the valve body.
- (b) Remove the oil strainer and gasket.

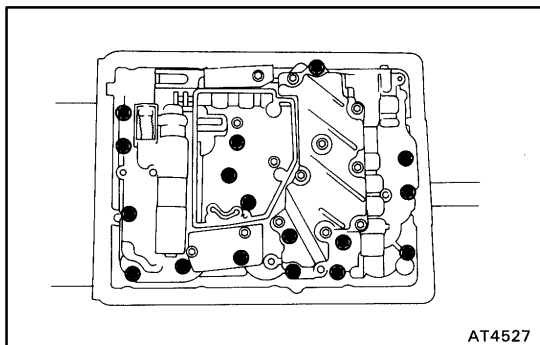

17. REMOVE VALVE BODY

(a) Remove the 17 bolts.

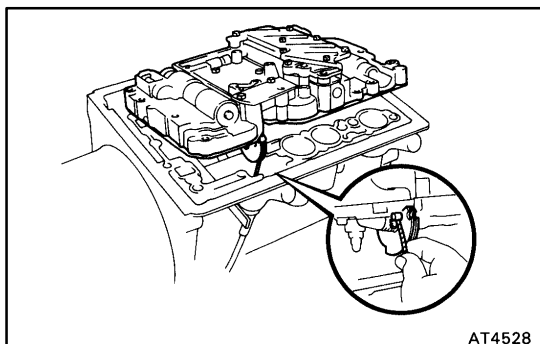

(b) Disconnect the throttle cable from the cam and remove the valve body.

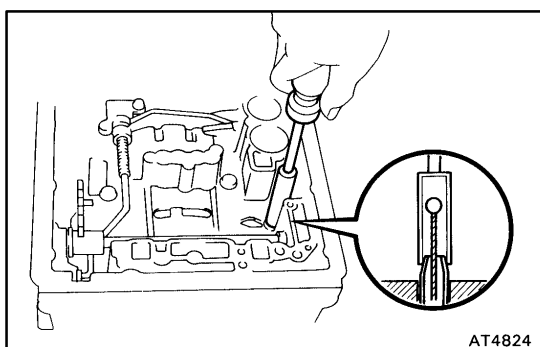

18. REMOVE THROTTLE CABLE

(a) Using a 10 mm socket driver, push the throttle cable end to remove it.

(b) Remove the O-ring.

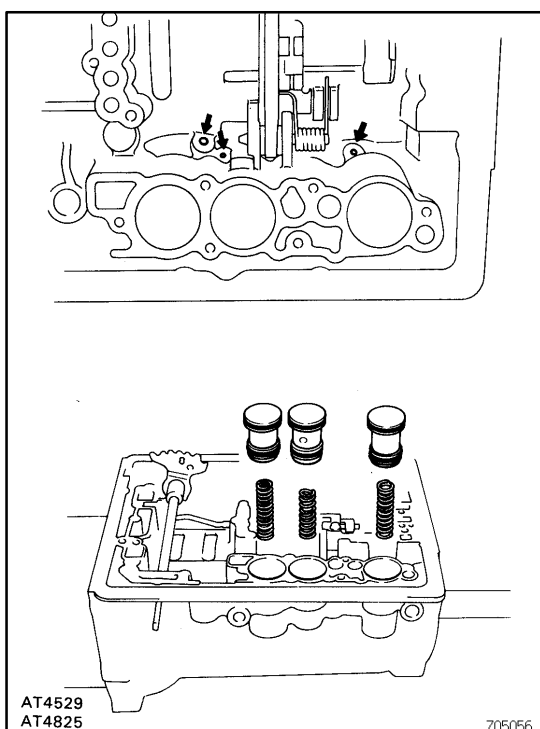

19. REMOVE ACCUMULATOR PISTONS AND SPRINGS

CAUTION: Keep face away to avoid injury. Do not use regular high-pressure air.

(a) Position a rag to catch each piston.

(b) Applying compressed air to the oil holes shown, and remove the 3 pistons and springs.

(c) Remove the 2 O-rings from each piston.

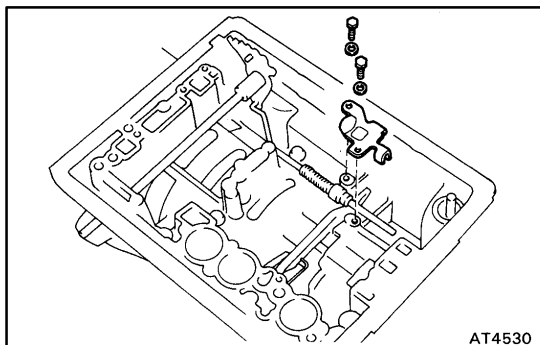

20. REMOVE PARKING LOCK ROD AND PAWL

- (a) Remove the 2 bolts and wave washers.
- (b) Remove the parking lock pawl bracket.

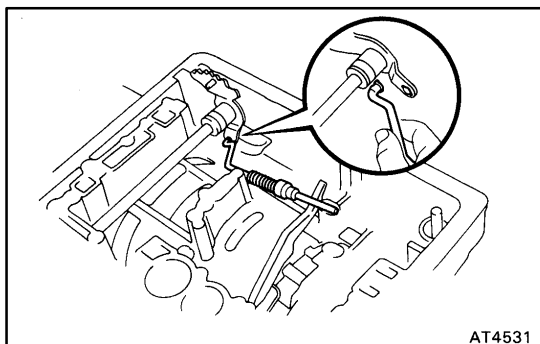

- (c) Disconnect the parking lock rod from the manual valve lever.

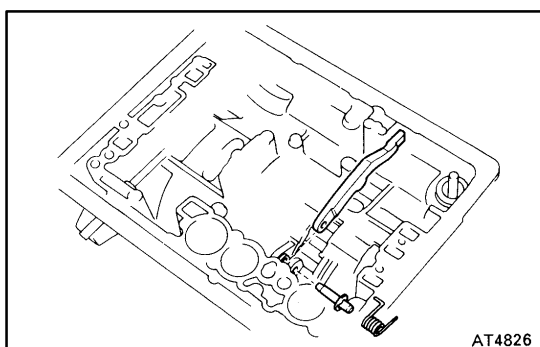

- (d) Pull out the shaft and remove the spring and lock pawl.
- (e) Remove the E-ring from the shaft.

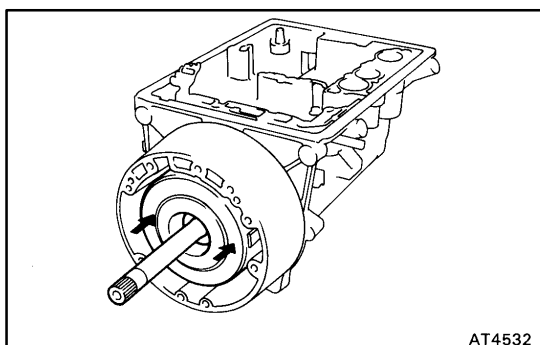

21. MEASURE INSTALLATION DISTANCE OF OVER-DRIVE DIRECT CLUTCH

HINT: Make a note of the distance for reassembly.

- (a) Push the input shaft and drum toward the rear to make sure the overdrive direct clutch is installed correctly.

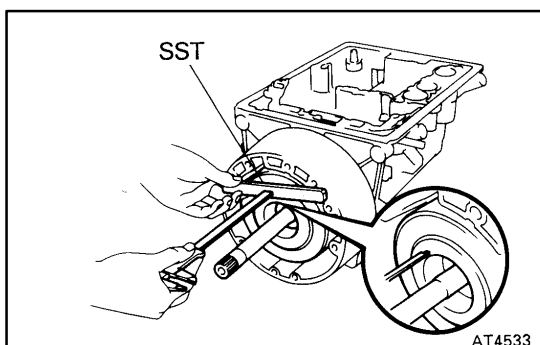

- (b) Place SST on the overdrive case.
SST 09350-20015 (09370-12010)
- (c) Using calipers, measure distance between the tops of SST and the clutch drum.

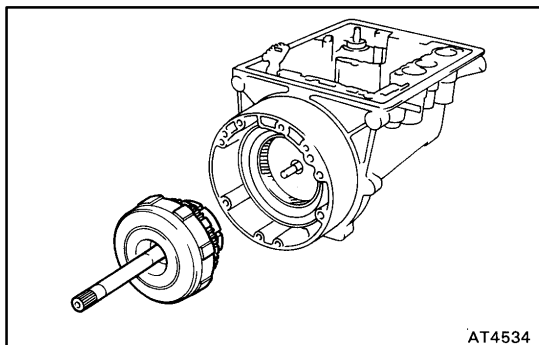

22. REMOVE OVERDRIVE PLANETARY GEAR, WITH OVERDRIVE DIRECT CLUTCH AND OVERDRIVE ONE-WAY CLUTCH

- (a) Remove the overdrive planetary gear with the overdrive direct clutch and overdrive one-way clutch from the overdrive case.

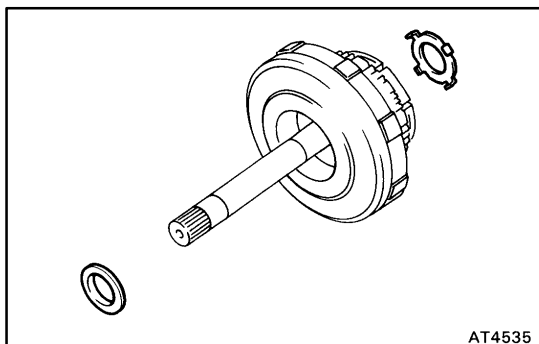

- (d) Remove the race and thrust washer.

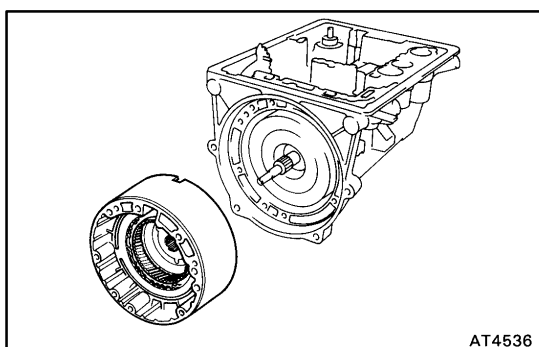

23. REMOVE OVERDRIVE CASE

- (a) Remove the overdrive case from the transmission case. HINT: When the overdrive case is removed, the front clutch sometimes adheres to it.

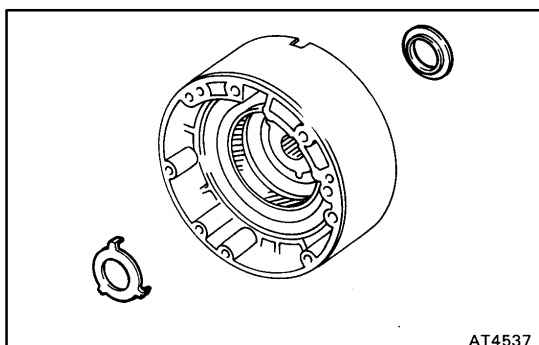

- (b) Remove the 2 races.

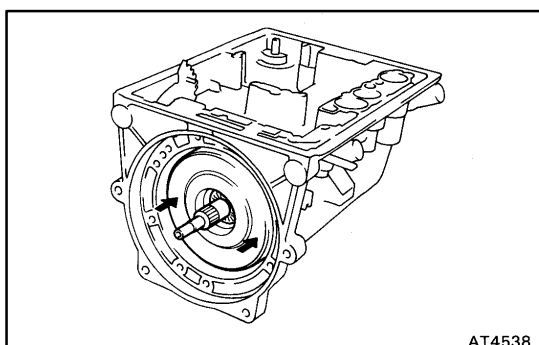

24. MEASURE INSTALLATION DISTANCE OF FRONT CLUTCH

HINT: Make a note of the distance for reassembly.

- (a) Push the input shaft and drum toward the rear to make sure the front clutch is installed correctly.

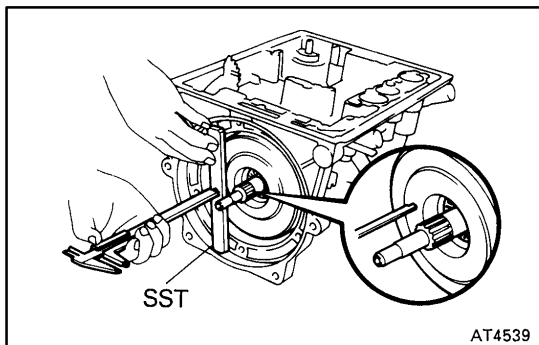

- (b) Place SST on the transmission case.
SST 09350-20015 (09370-12010)
- (c) Using calipers, measure distance between the tops of SST and the clutch drum.

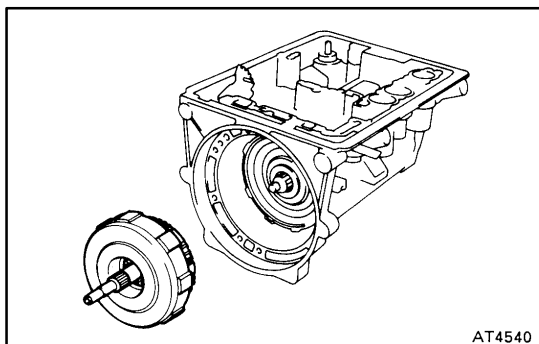

25. REMOVE FRONT CLUTCH

- (a) Remove the front clutch from the transmission case.

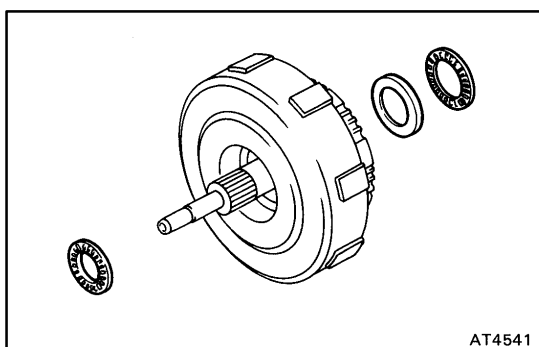

- (b) Remove the 2 bearings and a race.

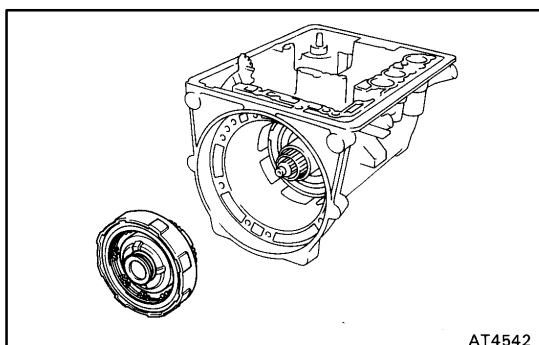

26. REMOVE REAR CLUTCH

- (a) Remove the rear clutch from the transmission case.

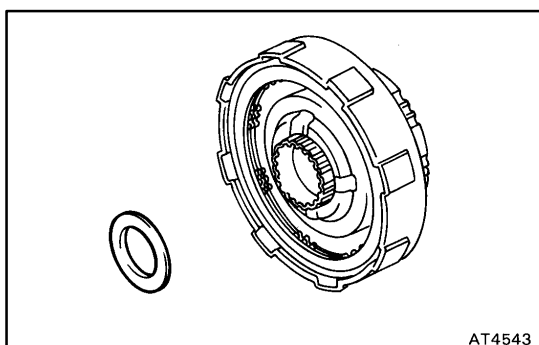

- (b) Remove the race.

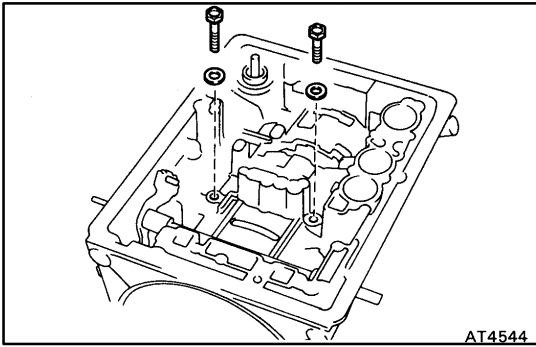

27. REMOVE CENTER SUPPORT

(a) Remove the 2 bolts and wave washers.

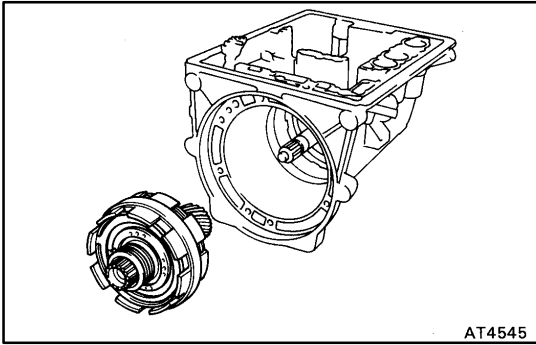

(b) Remove the center support from the transmission case.

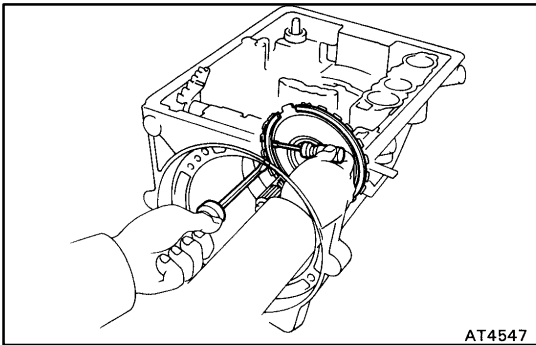

28. REMOVE FRONT PLANETARY GEAR UNIT

(a) Using 2 screwdrivers, remove the snap ring.

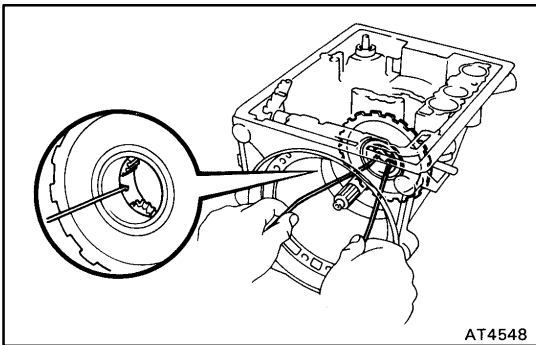

(b) Insert 2 wires into the planetary gear and remove it.

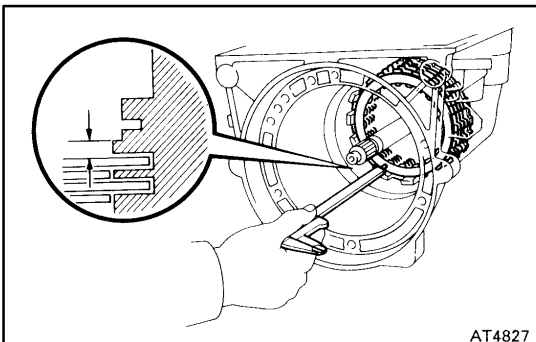

29. CHECK PACK CLEARANCE OF NO.3 BRAKE

Using calipers, measure the clearance between the disc and transmission case.

Clearance:

0.61-2.64 mm (0.0240-0.1039 in.)

If the values are nonstandard, inspect the discs.

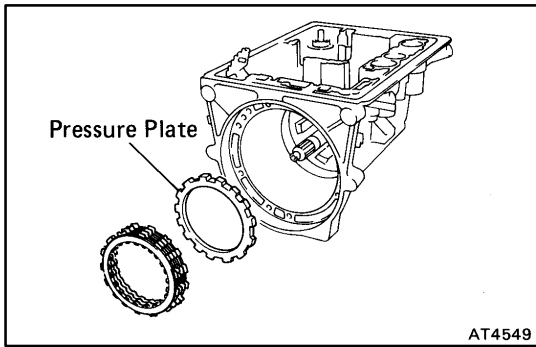

30. REMOVE NO.3 BRAKE PACK AND PRESSURE PLATE

- (a) Remove the 5 discs and 4 plates.
- (b) Remove the pressure plate.

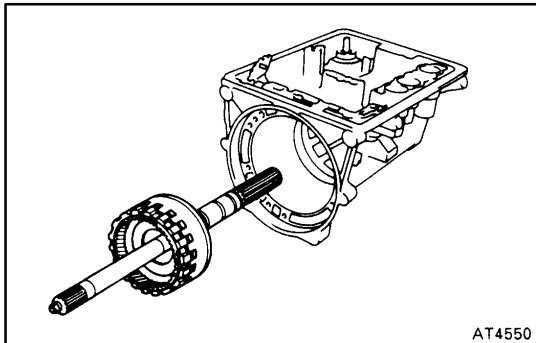

31. REMOVE REAR PLANETARY GEAR UNIT AND OUTPUT SHAFT

- (a) Remove the rear planetary gear unit and output shaft.

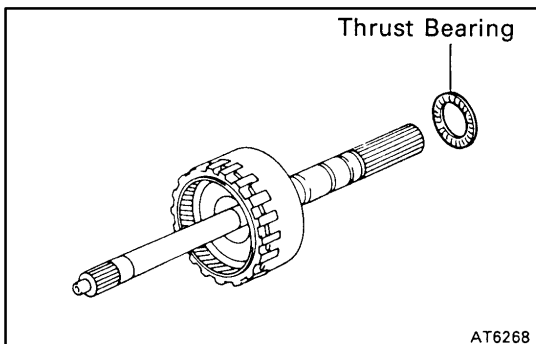

- (b) Remove the 2 bearings.

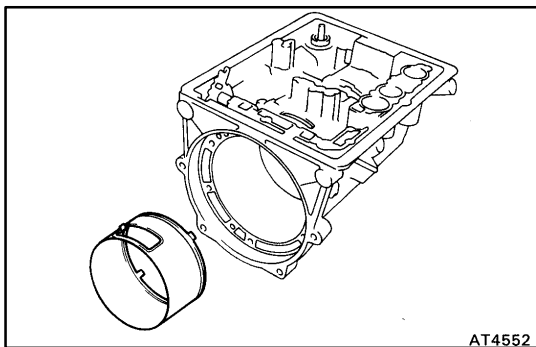

32. REMOVE BRAKE APPLY TUBE

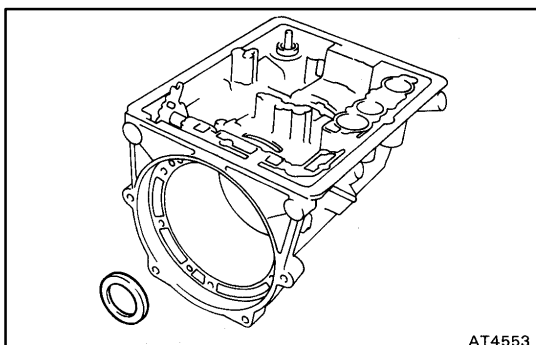

33. REMOVE RACE

Remove the race from the transmission case.

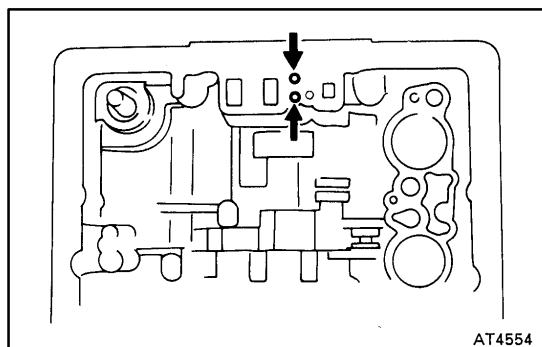

34. CHECK NO.3 BRAKE PISTONS MOVING

Make sure the No.3 brake pistons move smoothly when applying and releasing the compressed air into the transmission case.

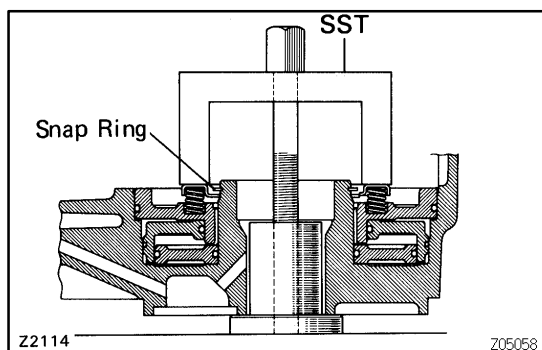

35. REMOVE COMPONENTS OF NO.3 BRAKE PISTON

(a) Set SST on the spring retainer, and compress the return springs.

SST 09350-20015 (09362-20040)

(b) Using a snap ring expander, remove the snap ring.

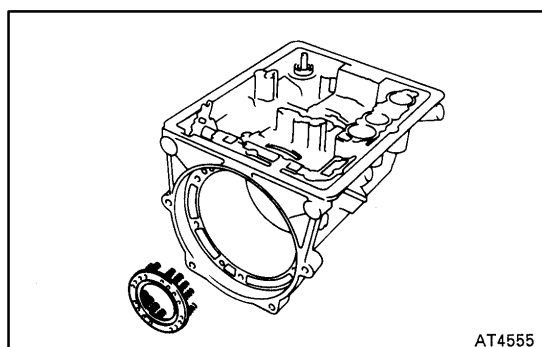

(c) Remove the piston return spring.

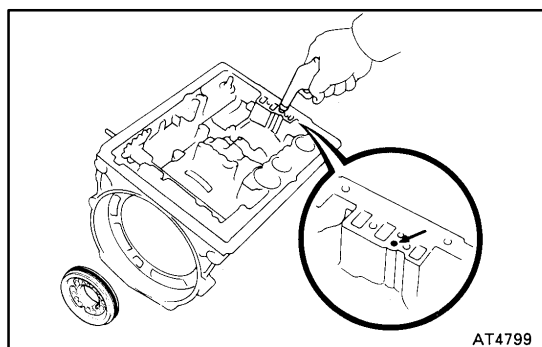

(d) Hold outer piston with hand, apply compressed air to the transmission case to the remove the outer piston. If the piston does not pop out with compressed air, lift the piston out with needle-nose pliers.

(e) Remove the O-ring from the outer piston.

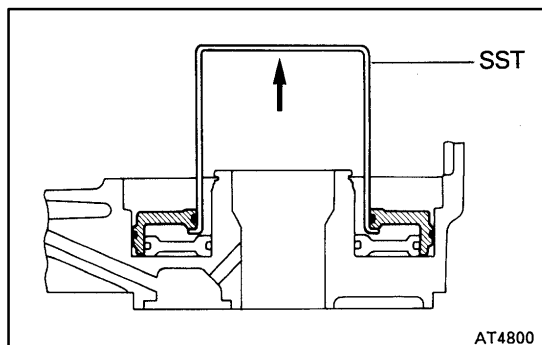

(f) Insert SST behind the reaction sleeve and gradually lift it out of the transmission case.

SST 09350-30020 (09350-07080)

(g) Remove the 2 O-rings from the reaction sleeve.

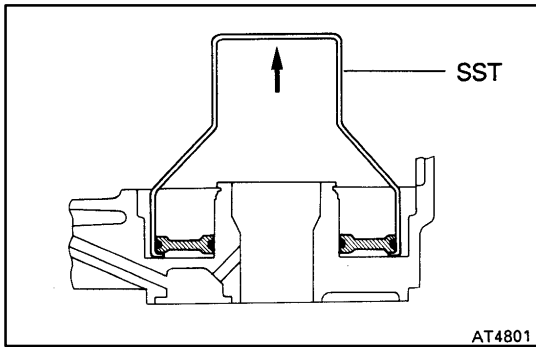

- (h) Insert SST behind the inner piston and gradually lift it out of the transmission case.
SST 09350-30020 (09350-07090)
- (i) Remove the 2 O-rings from the inner piston.

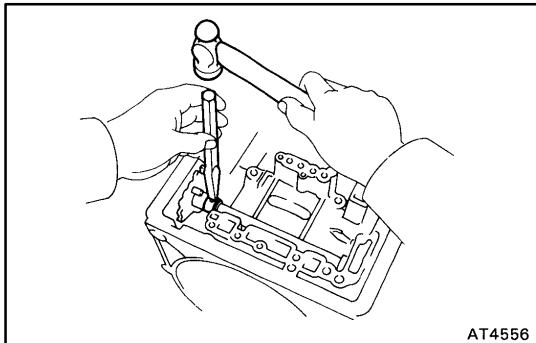

36. REMOVE MANUAL VALVE LEVER, SHAFT AND OIL SEALS

- (a) Using a chisel, cut off the spacer and slide it toward the lever.
- (b) Using a pin punch and hammer, drive out the pin.

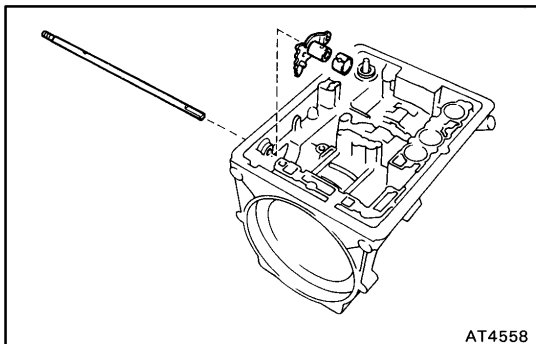

- (c) Pull the lever shaft out through the case and remove the lever.
- (d) Remove the spacer from the lever.

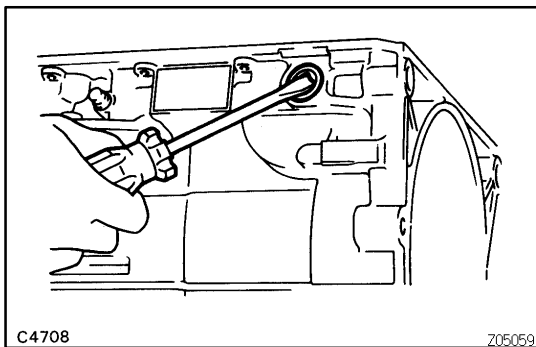

- (e) Using a screwdriver, remove the 2 oil seals.

COMPONENT PARTS

ATOAD-03

GENERAL NOTES

The instructions here are organized so that you work on only one component group at a time.

This will help avoid confusion from similar-looking parts of different subassemblies being on your workbench at the same time.

The component groups are inspected and repaired from the converter housing side.

As much as possible, complete the inspection, repair and assembly before proceeding to the next component group. If a component group cannot be assembled because parts are being ordered, be sure to keep all parts of that group in a separate container while proceeding with disassembly, inspection, repair and assembly of other component groups.

Recommended ATF:

DEXRON® II

GENERAL CLEANING NOTES:

1. All disassembled parts should be washed clean and any fluid passages and holes blown through with compressed air.
2. When using compressed air to dry parts, always aim away from yourself to prevent accidentally spraying automatic transmission fluid or kerosene on your face.
3. The recommended automatic transmission fluid or kerosene should be used for cleaning.

PARTS ARRANGEMENT:

1. After cleaning, the parts should be arranged in correct order to allow efficient inspection, repairs, and reassembly.
2. When disassembling a valve body, be sure to keep each valve together with the corresponding spring.
3. New discs for the brakes and clutches that are to be used for replacement must be soaked in transmission fluid for at least 15 minutes before assembly.

GENERAL ASSEMBLY:

1. All oil seal rings, clutch discs, clutch plates, rotating parts, and sliding surfaces should be coated with transmission fluid prior to reassembly.
2. All gaskets and rubber O-rings should be replaced.
3. Make sure that the ends of a snap ring are not aligned with one of the cutouts and are installed in the groove correctly.
4. If a worn bushing is to be replaced, the subassembly containing that bushing must also be replaced.
5. Check thrust bearings and races for wear or damage. Replace if necessary.
6. Use petroleum jelly to keep parts in place.

OIL PUMP COMPONENTS

AT0AE-03

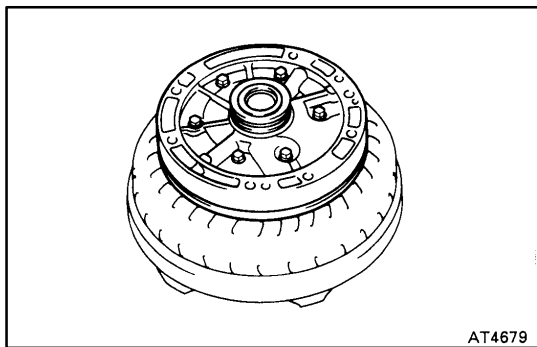
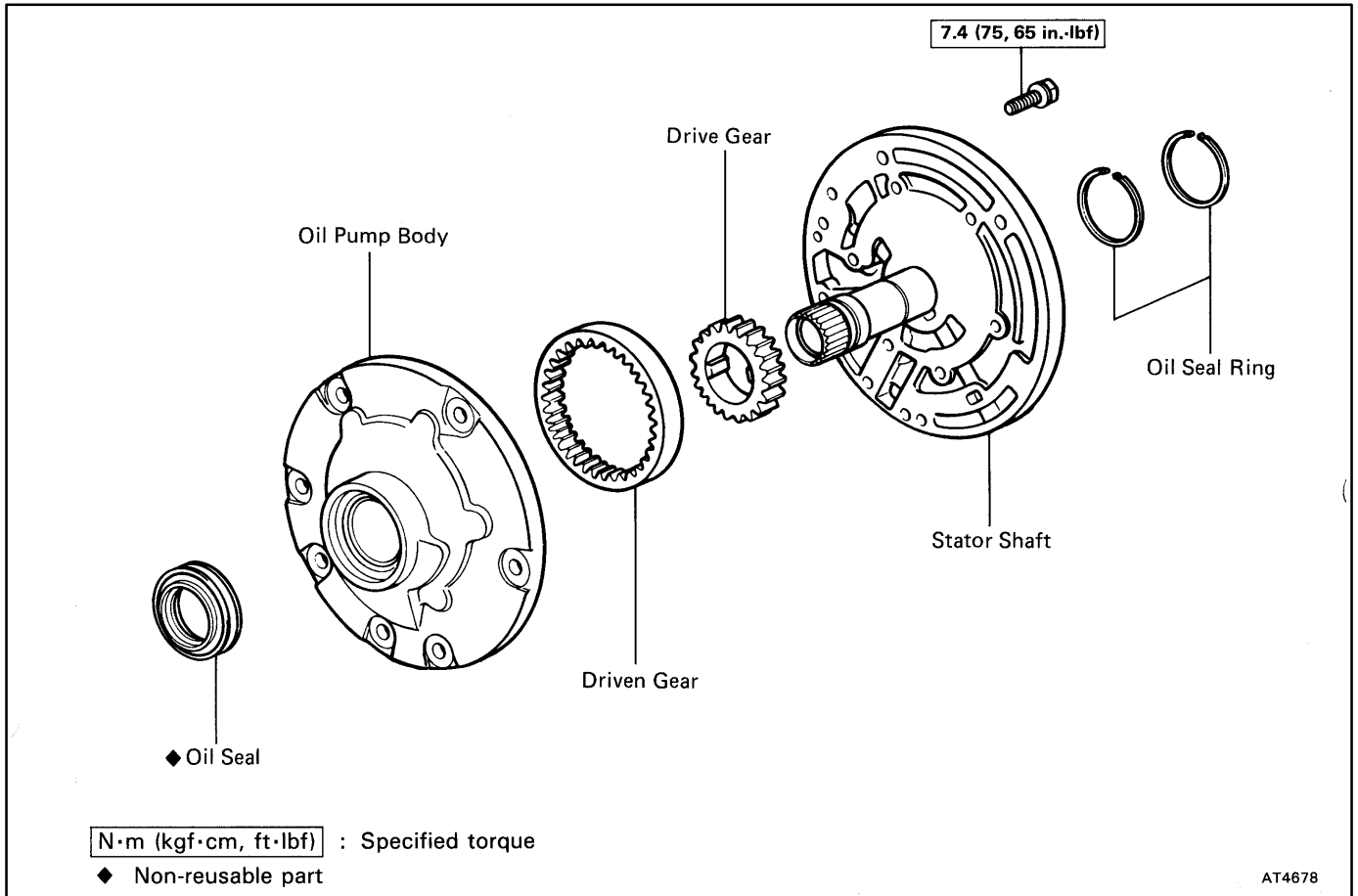

OIL PUMP DISASSEMBLY

AT0AF-03

1. USE TORQUE CONVERTER CLUTCH AS WORK STAND

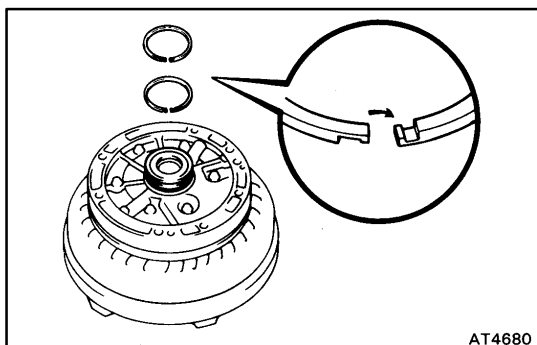

2. REMOVE OIL SEAL RINGS

Remove the 2 oil seal rings.

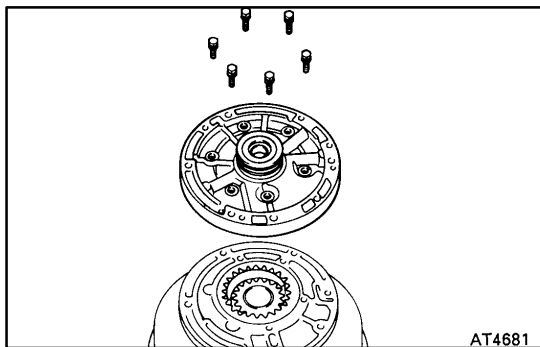

3. REMOVE STATOR SHAFT

Remove the 6 bolts, and then remove the stator shaft from the oil pump body.

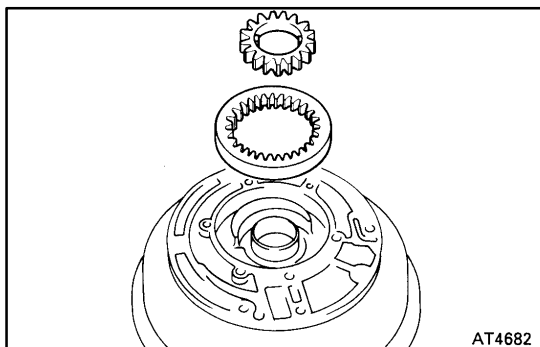

4. REMOVE OIL PUMP DRIVE GEAR AND DRIVEN GEAR

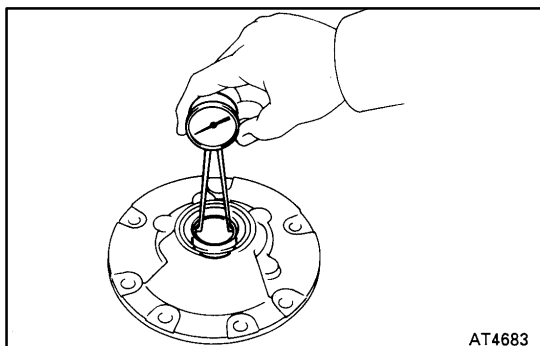

OIL PUMP INSPECTION

AT0AG-03

1. CHECK OIL PUMP BODY BUSHING

Using a dial indicator, measure the inside diameter of the oil pump body bushing.

Maximum inside diameter:

38.19 mm (1.5035 in.)

If the inside diameter is greater than the maximum, replace the oil pump body.

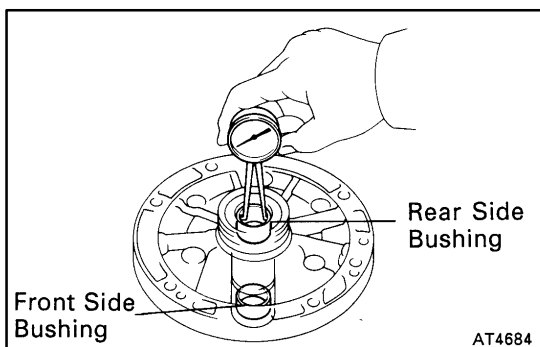

2. CHECK STATOR SHAFT BUSHING

Using a dial indicator, measure the inside diameter of the stator shaft bushings.

Maximum inside diameter:

Front side 21.58 mm (0.8496 in.)

Rear side 21.58 mm (0.8496 in.)

If the inside diameter is greater than the maximum, replace the stator shaft.

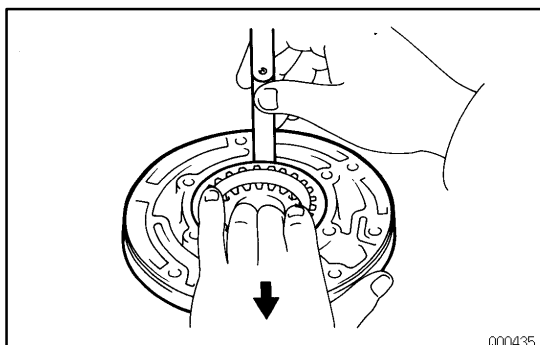

3. CHECK BODY CLEARANCE OF DRIVEN GEAR

Push the driven gear to one side of the body. Using a feeler gauge, measure the clearance.

Standard body clearance:

0.07-0.15 mm (0.0028-0.0059 in.)

Maximum body clearance:

0.3 mm (0.012 in.)

If the body clearance is greater than the maximum, replace the drive gear, driven gear or pump body.

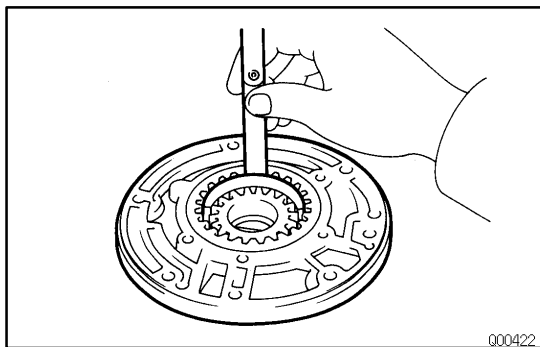

4. CHECK TIP CLEARANCE OF DRIVEN GEAR

Measure between the driven gear teeth and the crescent-shaped part of the pump body.

Standard tip clearance:

0.11-0.14 mm (0.0043-0.0055 in.)

Maximum tip clearance:

0.3 mm (0.012 in.)

If the tip clearance is greater than the maximum, replace the drive gear, driven gear or pump body.

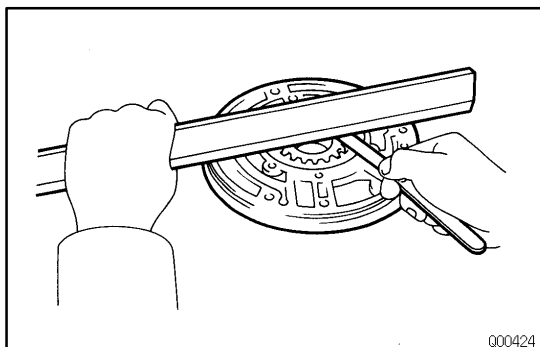

5. CHECK SIDE CLEARANCE OF BOTH GEARS

Using a steel straight edge and a feeler gauge, measure the side clearance of both gears.

Standard side clearance:

0.02-0.05 mm (0.0008-0.0020 in.)

Maximum side clearance:

0.1 mm (0.004 in.)

If the side clearance is greater than the maximum, replace the drive gear, driven gear or pump body.

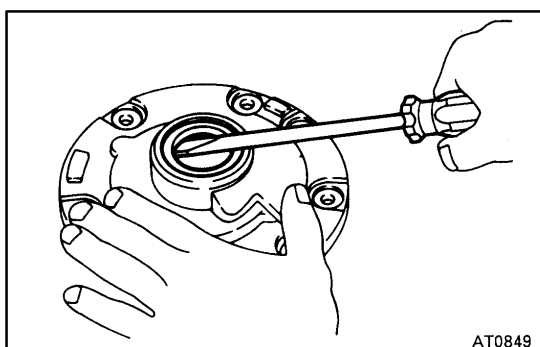

6. IF NECESSARY, REPLACE OIL SEAL

(a) Pry off the oil seal with a screwdriver.

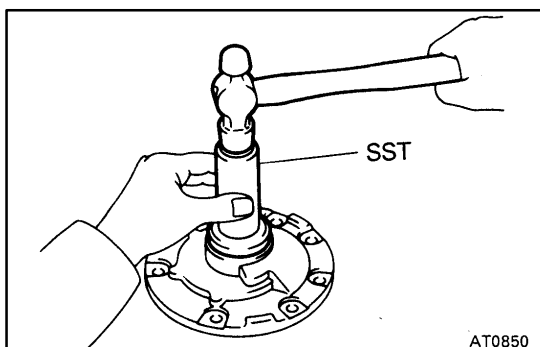

(b) Using SST, install a new oil seal.

The oil seal end should be flushed with the outer edge of the pump body.

SST 09350-20015 (09388-20010)

(c) Coat the oil seal lip with MP grease.

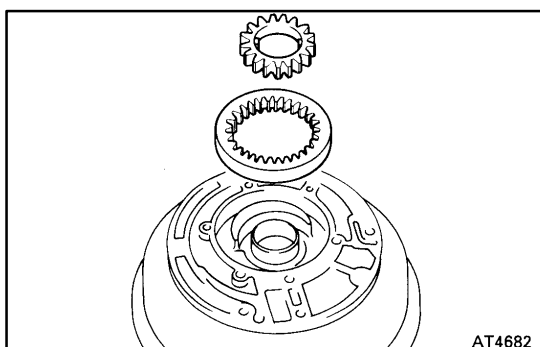

OIL PUMP ASSEMBLY

1. INSTALL DRIVEN GEAR AND DRIVE GEAR TO OIL PUMP BODY

(a) Place the oil pump body on the torque converter clutch.

(b) Coat the driven gear and drive gear with ATF.

(c) Install the driven gear and drive gear.

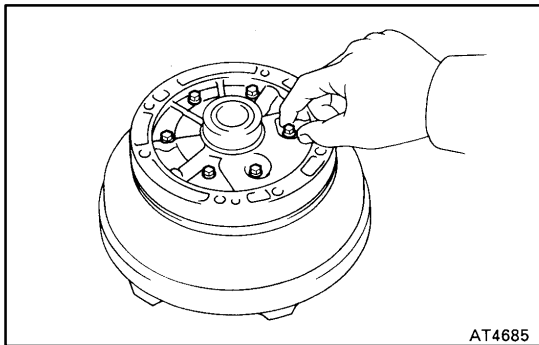

2. INSTALL STATOR SHAFT TO OIL PUMP BODY

- (a) Align the stator shaft with each bolt hole.
- (b) Temporarily install the 6 bolts.

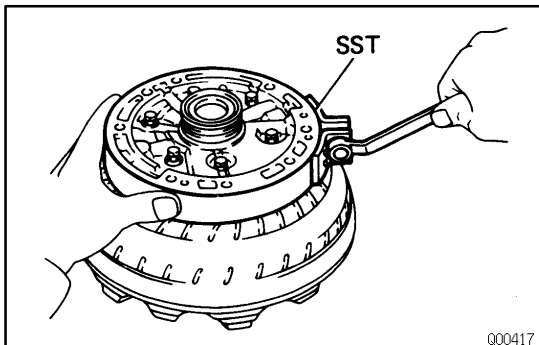

- (c) Install SST around the pump body and stator shaft.
SST 09350-20015 (09363-20010)
- (d) Tighten SST to align the pump body and stator shaft.

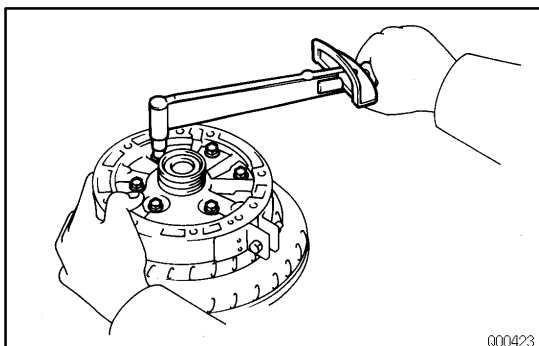

- (e) Tighten the 6 bolts.
Torque: 7.4 N-m (75 kgf-cm, 65 in.-lbf)
- (f) Remove SST.

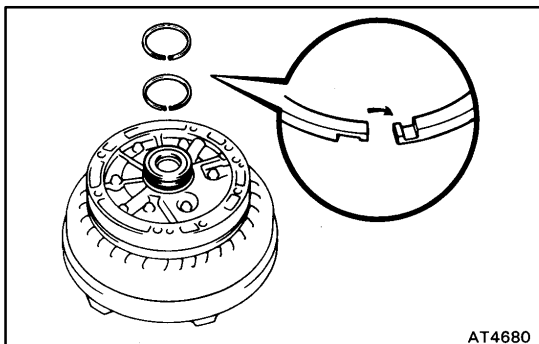

3. INSTALL OIL SEAL RINGS

- (a) Coat the 2 oil seal rings with ATF.
- (b) Install 2 oil seal rings to the stator shaft, then snug them down by squeezing their ends together.

NOTICE: Do not spread the ring ends too much.

HINT: After installing the oil seal rings, check that they rotate smoothly.

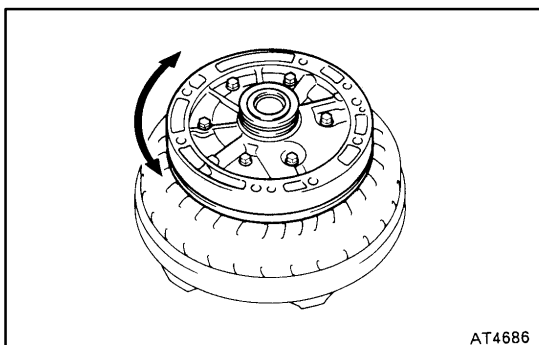

4. CHECK OIL PUMP DRIVE GEAR ROTATION

Make sure the drive gear rotates smoothly.

OVERDRIVE DIRECT CLUTCH COMPONENTS

AT0AJ-02

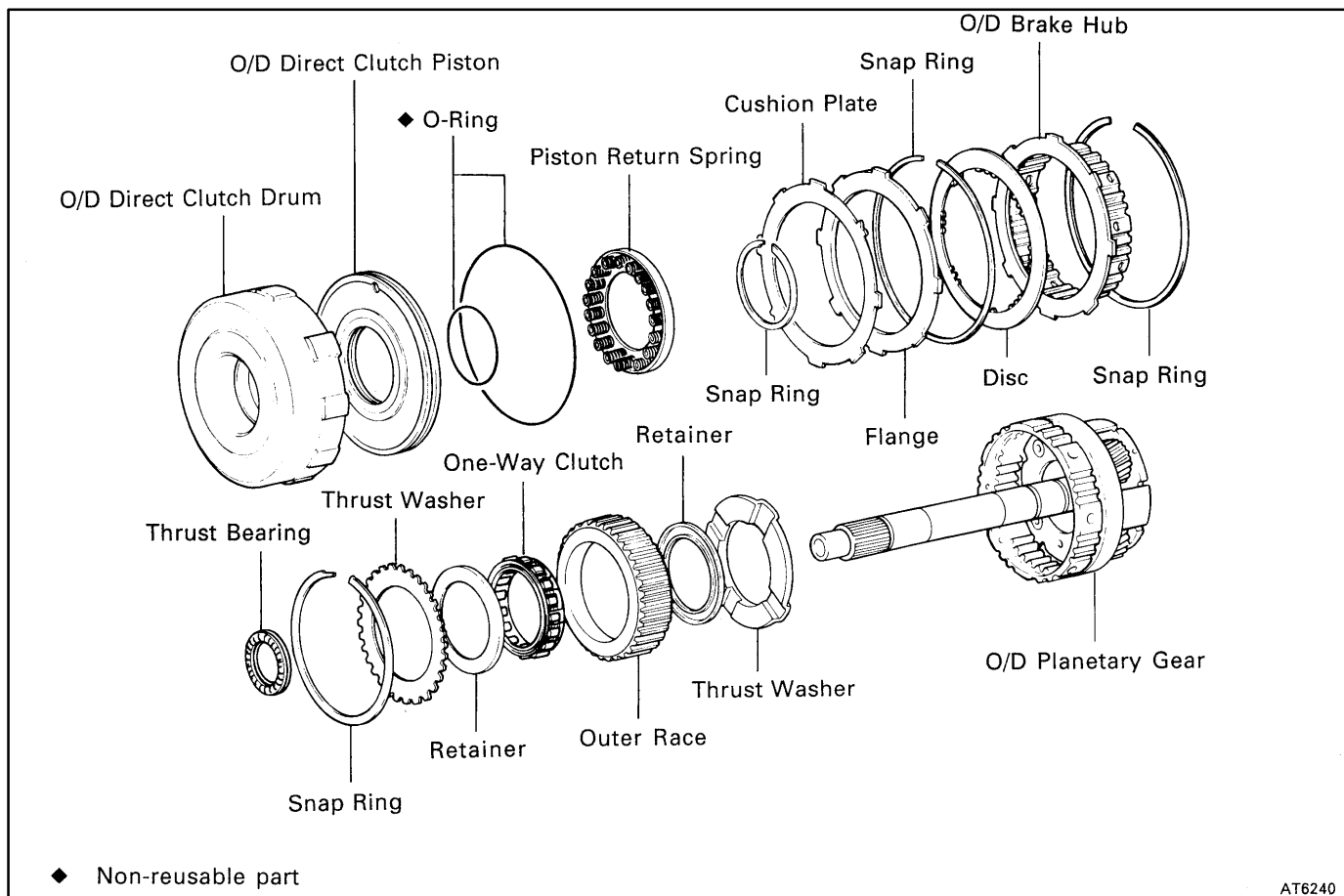

AT0AK-03

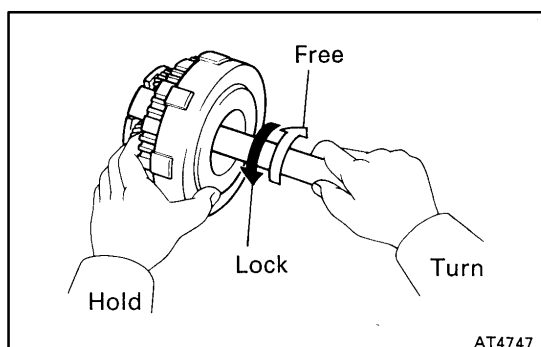

OVERDRIVE PLANETARY GEAR, OVERDRIVE DIRECT CLUTCH AND OVERDRIVE ONE-WAY CLUTCH DISASSEMBLY

1. **CHECK OPERATION OF ONE-WAY CLUTCH**
Hold the O/D direct clutch drum and turn the input shaft. The input shaft turns freely clockwise and locks counter clockwise.
2. **REMOVE OVERDRIVE DIRECT CLUTCH ASSEMBLY FROM OVERDRIVE PLANETARY GEAR**
 - (a) Remove the overdrive direct clutch from the overdrive planetary gear.

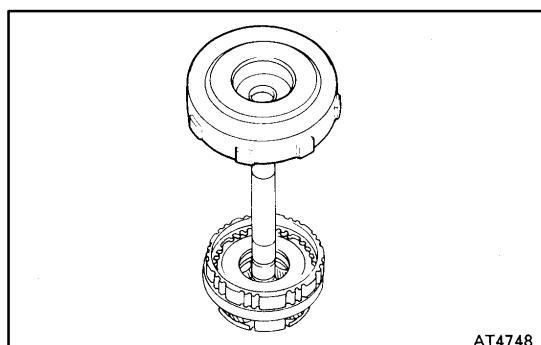

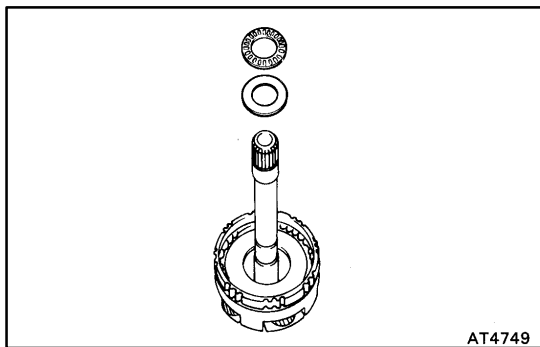

(b) Remove the bearing and race from the planetary carrier.

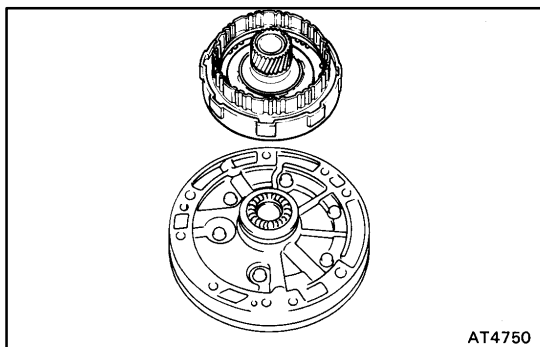

3. CHECK PISTON STROKE OF OVERDRIVE DIRECT CLUTCH

(a) Place the O/D direct clutch assembly onto the oil pump.

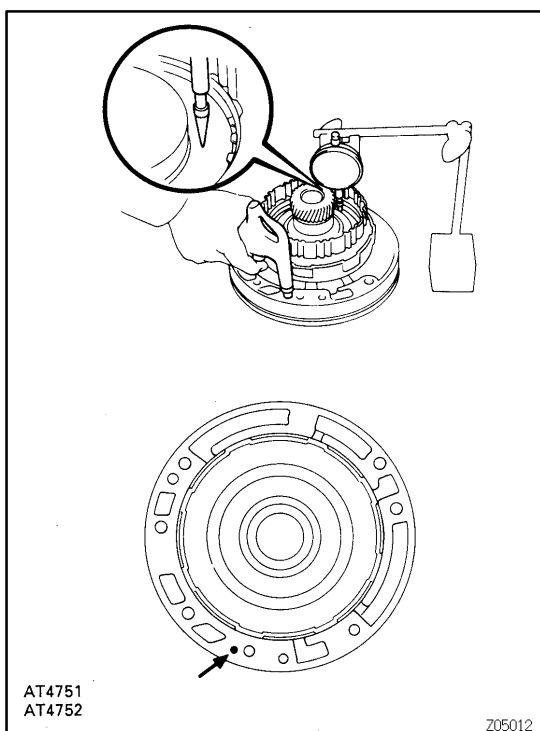

(b) Using a dial indicator, measure the O/D direct clutch piston stroke while applying and releasing compressed air (392-785 kPa, 4-8 kgf/cm², 57-114 psi).

Piston stroke:

1.77-2.58 mm (0.0697-0.1016 in.)

If the values are nonstandard, inspect the discs.

(c) Remove the O/D direct clutch assembly from the oil pump.

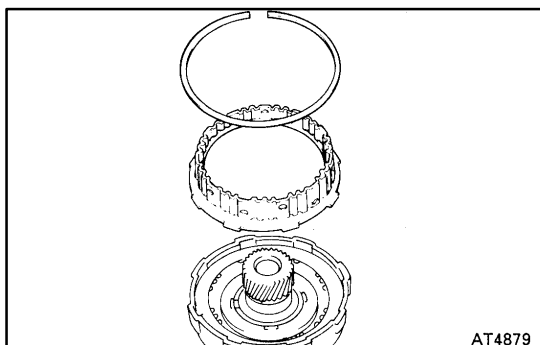

4. REMOVE OVERDRIVE BRAKE HUB

(a) Using a screwdriver, remove the snap ring.

(b) Remove the O/D brake hub.

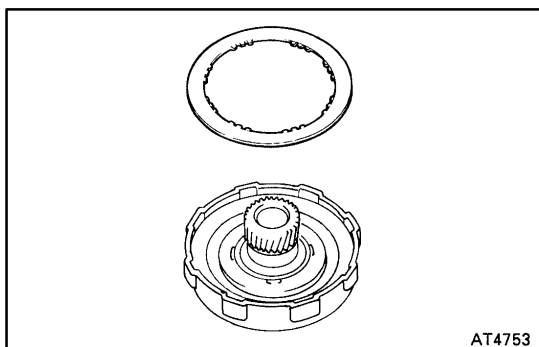

5. REMOVE DISC

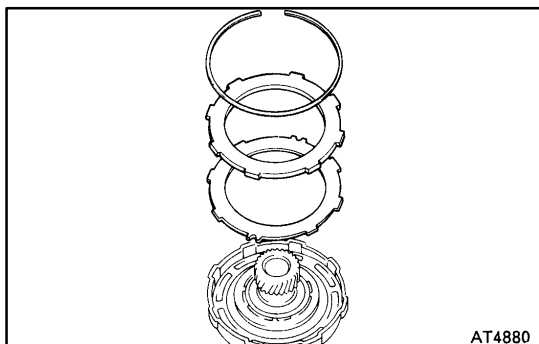

6. REMOVE FLANGE AND CUSHION PLATE

- (a) Using a screwdriver, remove the snap ring.
- (b) Remove the flange and cushion plate.

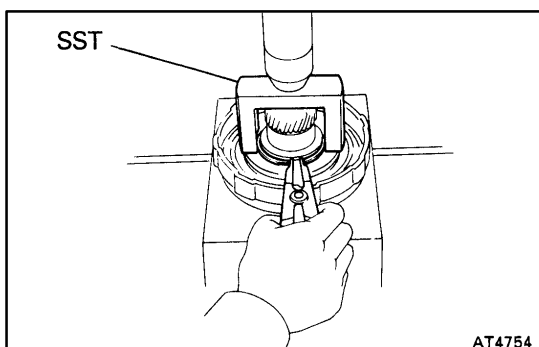

7. REMOVE PISTON RETURN SPRINGS

- (a) Place SST on the spring seat and compress the return springs with a shop press.
SST 09350-20015 (09369-20040)
- (b) Using a snap ring expander, remove the snap ring.

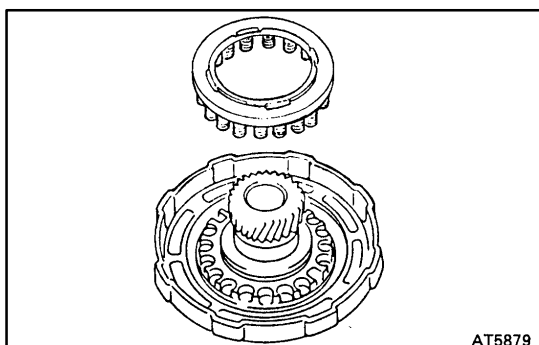

- (c) Remove the spring seat and 18 springs.

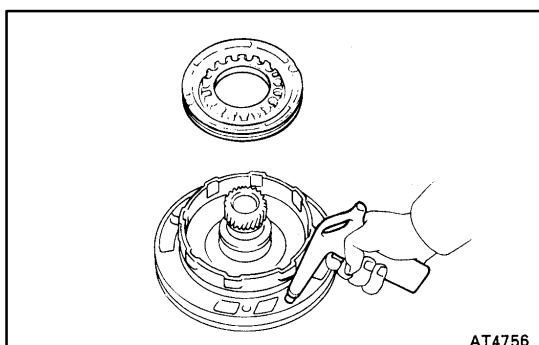

8. REMOVE OVERDRIVE DIRECT CLUTCH PISTON

- (a) Place the O/D direct clutch onto the oil pump.
- (b) Hold the O/D direct clutch piston and apply compressed air to the oil pump to remove the O/D direct clutch piston.
HINT: Make sure the direct clutch piston is square in the drum before applying compressed air.
- (c) Remove the 2 O-rings from the piston.

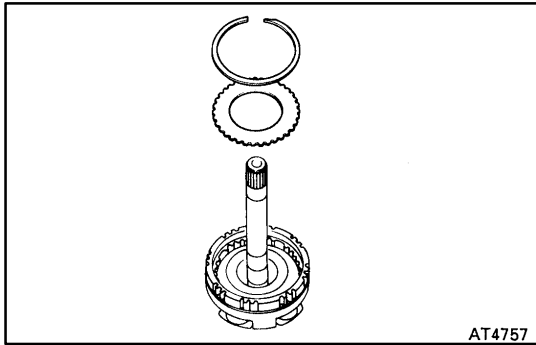

9. REMOVE THRUST WASHER

- (a) Using a screwdriver, remove the snap ring.
- (b) Remove the thrust washer.

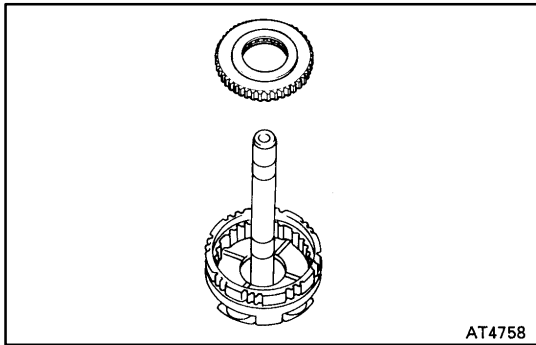

10. REMOVE ONE-WAY CLUTCH ASSEMBLY

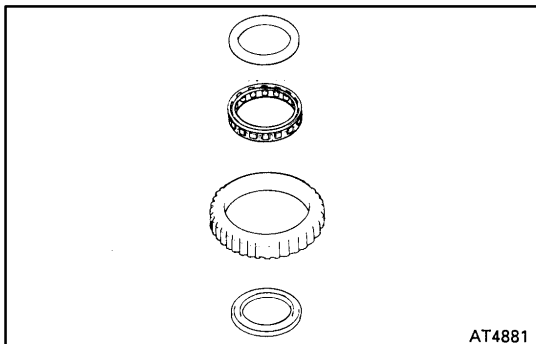

11. DISASSEMBLE ONE-WAY CLUTCH

- (a) Remove the 2 retainers from both sides.
- (b) Remove the one-way clutch from the outer race.

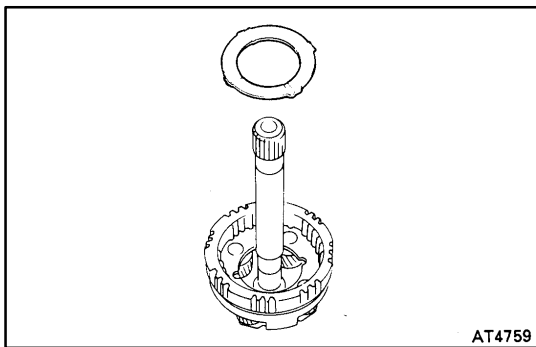

12. REMOVE THRUST WASHER

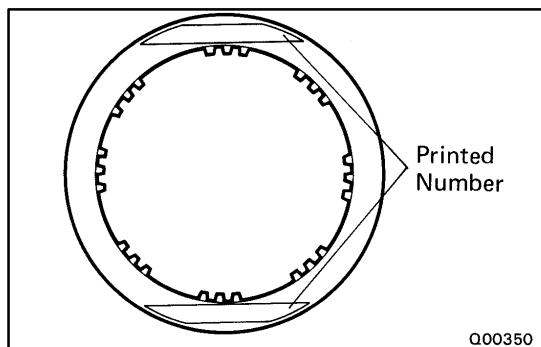

OVERDRIVE PLANETARY GEAR AND OVERDRIVE DIRECT CLUTCH INSPECTION

1. INSPECT DISC AND FLANGE

Check to see if the sliding surface of the disc and flange are worn or burnt. If necessary, replace them.

HINT:

- ★ If the lining of the disc is peeling off or discolored, or even if a parts of the printed numbers are defaced, replace disc.
- ★ Before assembling new disc, soak it in ATF for at least 15 minutes.

2. CHECK OVERDRIVE DIRECT CLUTCH PISTON

- (a) Check that check ball is free by shaking the piston.
- (b) Check that the valve does not leak by applying low-pressure compressed air.

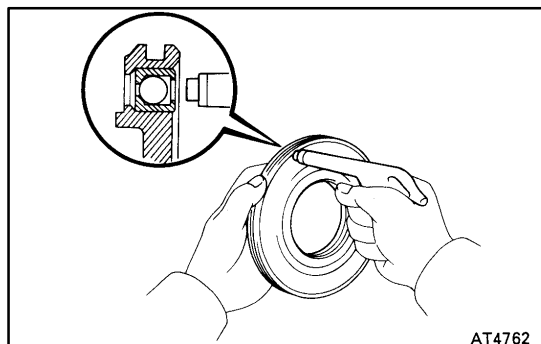

3. CHECK OVERDRIVE DIRECT CLUTCH DRUM BUSHINGS

Using a dial indicator, measure the inside diameter of the clutch drum bushings.

Maximum inside diameter:

23.14 mm (0.9110 in.)

If the inside diameter is greater than the maximum, replace the clutch drum.

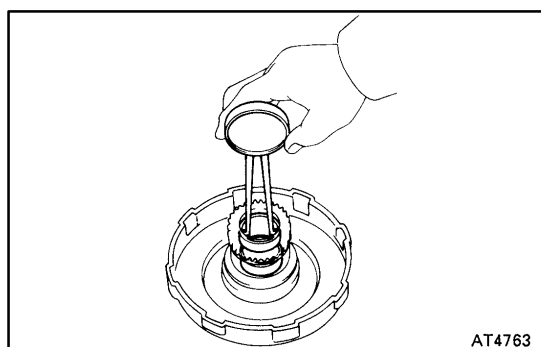

4. CHECK OVERDRIVE PLANETARY GEAR BUSHING

Using a dial indicator, measure the inside diameter of the planetary gear bushing.

Maximum inside diameter:

11.27 mm (0.4437 in.)

If the inside diameter is greater than the maximum, replace the planetary gear.

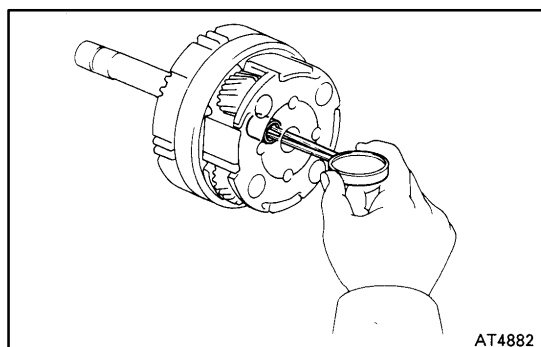

5. MEASURE PLANETARY PINION GEAR THRUST CLEARANCE

Using a feeler gauge, measure the planetary pinion gear thrust clearance.

Standard clearance:

0.20-0.50 mm (0.0079-0.0197 in.)

If the clearance is non-standard, inspect the planetary gear thrust washer.

If necessary, replace the planetary gear assembly.

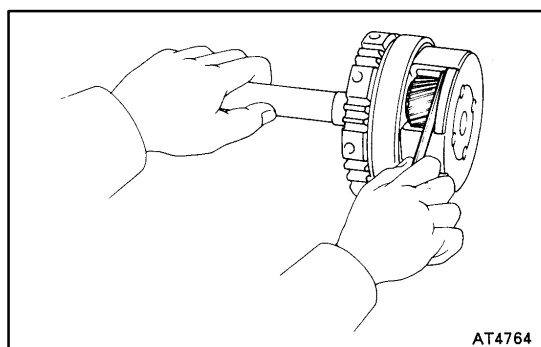

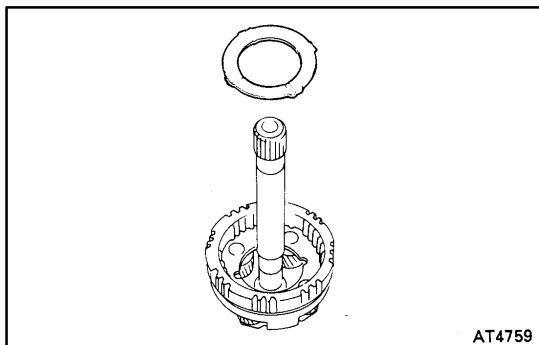

AT4759

OVERDRIVE PLANETARY GEAR, OVERDRIVE DIRECT CLUTCH AND OVERDRIVE ONE-WAY CLUTCH ASSEMBLY

1. INSTALL THRUST WASHER

Install the thrust washer to the overdrive planetary gear, the grooved side facing upward.

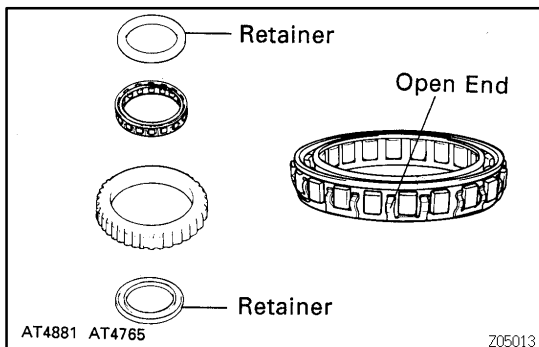

AT4881 AT4765

Z05013

2. ASSEMBLE ONE-WAY CLUTCH

- (a) Install the one-way clutch into the outer race, the open end of the retainers facing upward.
- (b) Install the 2 retainers to both sides.

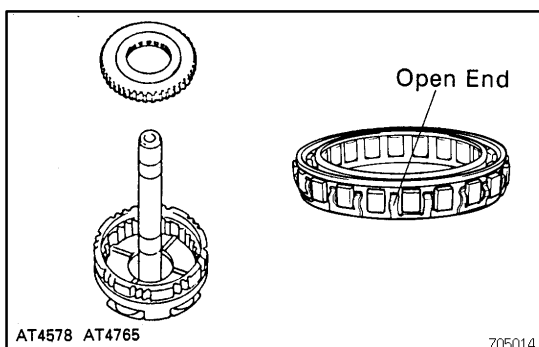

AT4578 AT4765

Z05014

3. INSTALL ONE-WAY CLUTCH ASSEMBLY

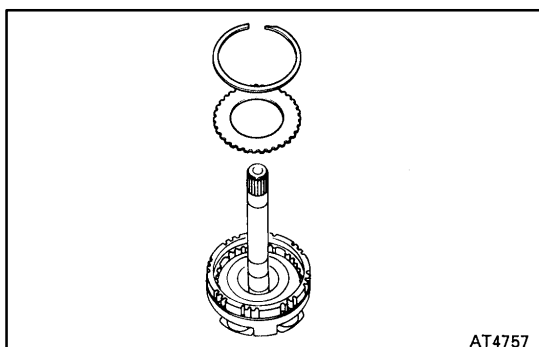

AT4757

4. INSTALL THRUST WASHER

- (a) Install the thrust washer.
- (b) Using a screwdriver, install the snap ring.

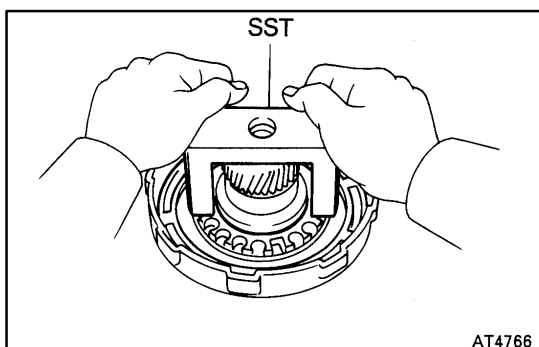

AT4766

5. INSTALL OVERDRIVE DIRECT CLUTCH PISTON

- (a) Coat new O-rings with ATF and install them on the O/D direct clutch piston.
- (b) Place SST on the direct clutch piston.
SST 09350-20015 (09369-20040)
- (c) Being careful not to damage the O-rings, press in the direct clutch piston into the clutch drum with both hands.

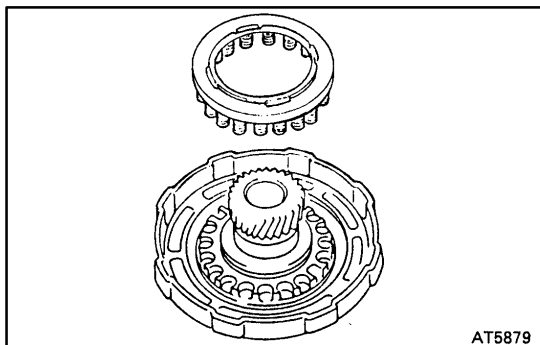

6. INSTALL PISTON RETURN SPRINGS

(a) Install the 18 springs and spring seat.

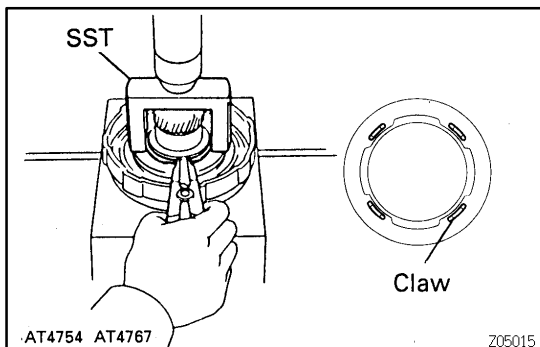

(b) Place SST on the spring seat, and compress the return springs with a shop press.

SST 09350-20015 (09369-20040)

(c) Install the snap ring with a snap ring expander. Be sure the end gap of the snap ring is not aligned with the spring seat claw.

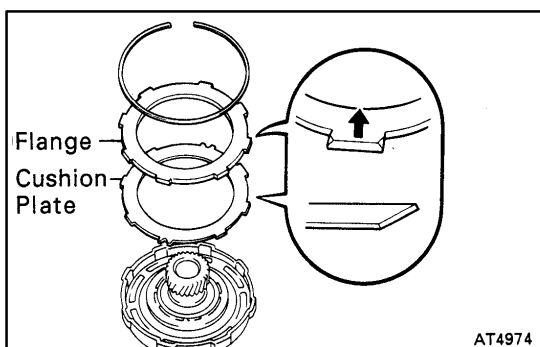

7. INSTALL CUSHION PLATE AND FLANGE

(a) Install the cushion plate.

(b) Install flange, the rounded edge facing upward.

(c) Install the snap ring. Be sure the end gap of the snap ring is not aligned with the cutout portion of the drum.

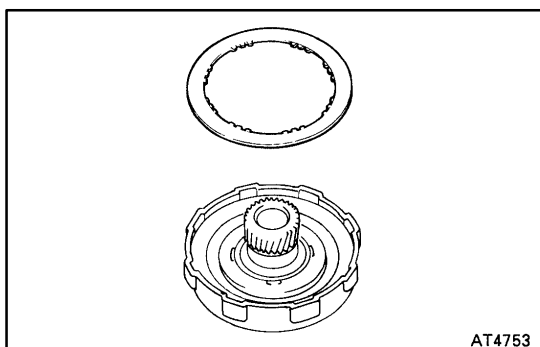

8. INSTALL DISC

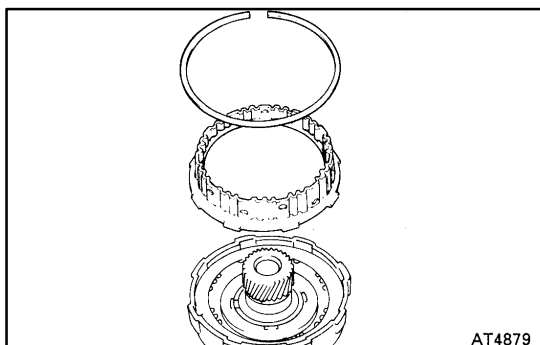

9. INSTALL OVERDRIVE BRAKE HUB

(a) Install the O/D brake hub.

(b) Using a screwdriver, install the snap ring. Be sure the end gap of the snap ring is not aligned with the cutout portion of the drum.

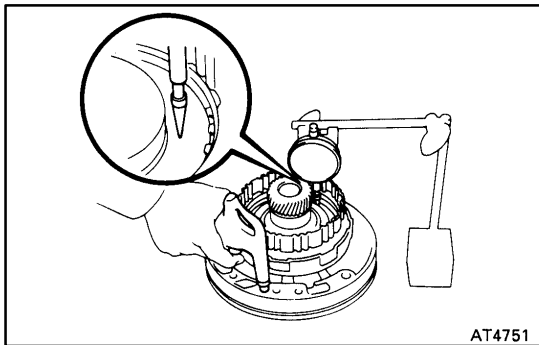

10. CHECK PISTON STROKE OF OVERDRIVE DIRECT CLUTCH

- (a) Place the O/D direct clutch assembly onto the oil pump.
- (b) Using dial indicator, measure the overdrive direct clutch piston stroke while applying and releasing compressed air (392-785 kPa, 4-8 kgf/cm², 57-114 psi).

Piston stroke:

1.77-2.58 mm (0.0697-0.1016 in.)

If the piston stroke is less than the limit, parts may have been assembled incorrectly, check and reassemble again.

11. INSTALL OVERDRIVE DIRECT CLUTCH ASSEMBLY

- (a) Coat the race and bearing with petroleum jelly and install them onto the O/D planetary gear.

Bearing and race diameter

mm (in.)

	Inside	Outside
Bearing	24.9 (0.980)	37.5 (1.476)
Race	25.0 (0.984)	37.4 (1.472)

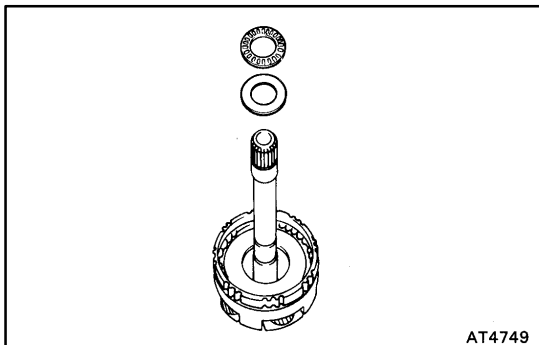

- (b) Install the direct clutch assembly onto the O/D planetary gear.

HINT: Mesh the splines of the O/D planetary gear with the flukes of the disc by rotating and pushing the O/D planetary gear.

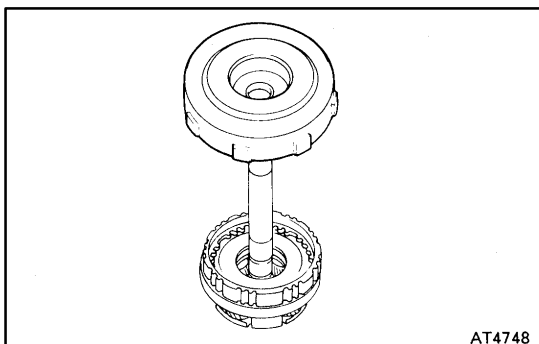

12. CHECK OPERATION OF ONE-WAY CLUTCH

Hold the O/D direct clutch drum and turn the input shaft. The input shaft turns freely clockwise and locks counter-clockwise.

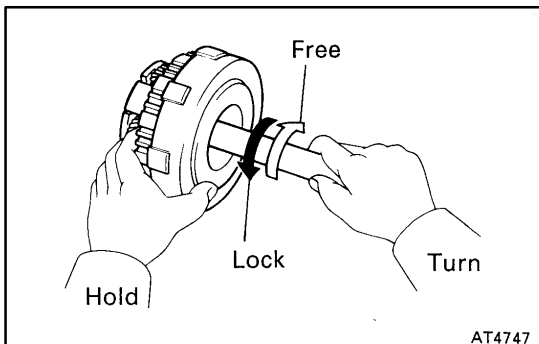

OVERDRIVE BRAKE COMPONENTS

AT0AN-02

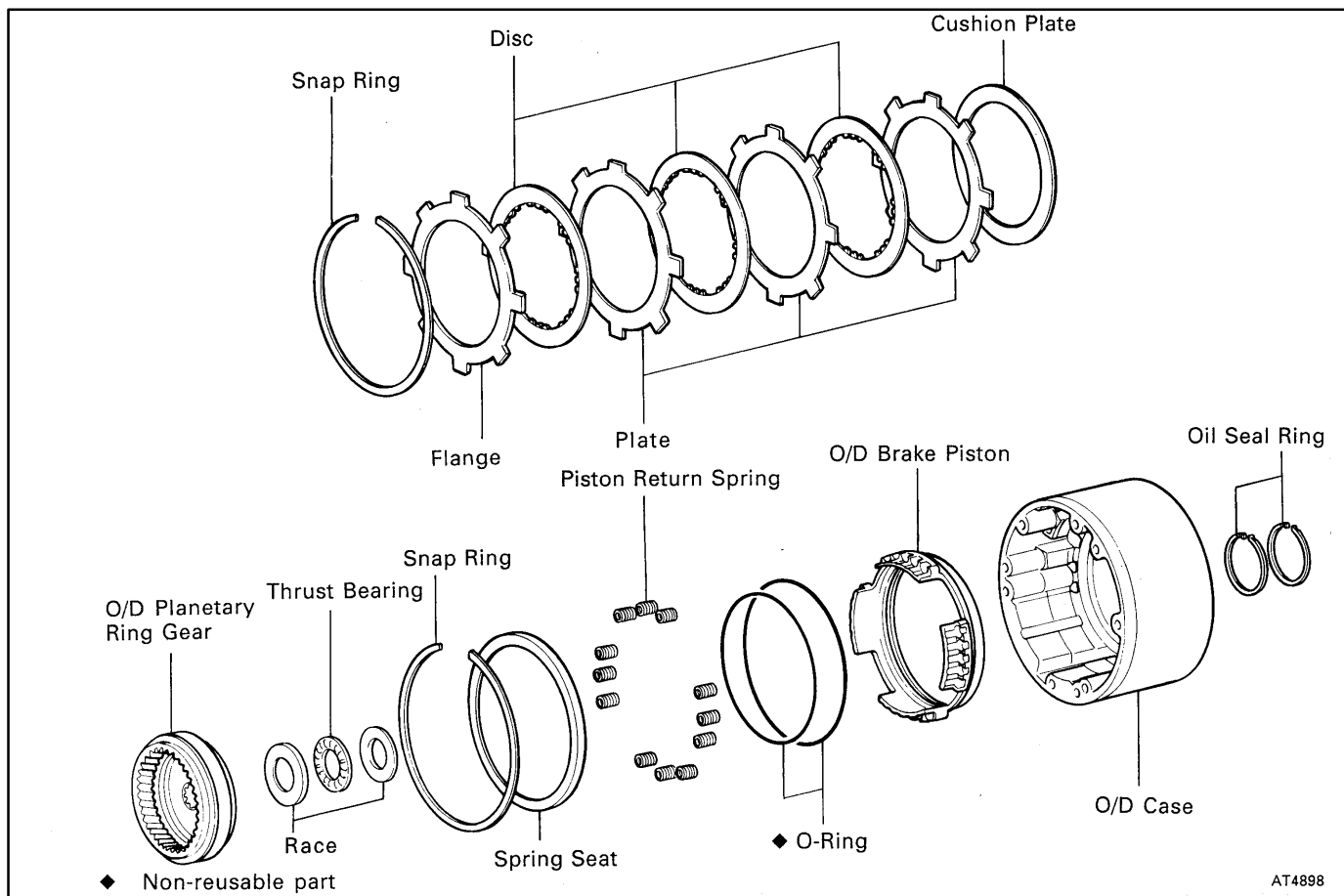

AT4898

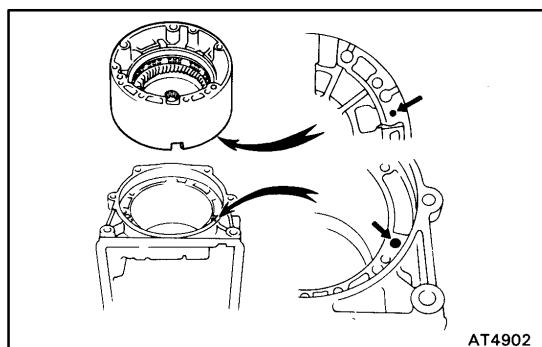

AT4902

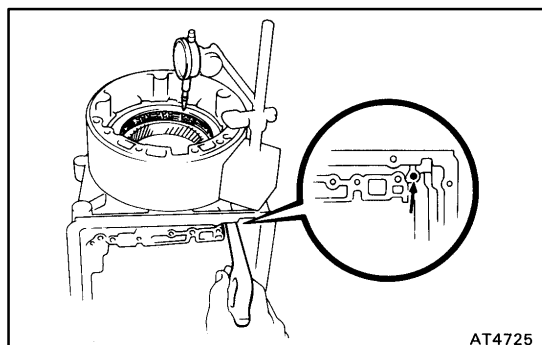

AT4725

OVERDRIVE BRAKE DISASSEMBLY

AT0AP-02

1. CHECK PISTON STROKE OF OVERDRIVE BRAKE

- (a) Place the O/D case assembly onto the transmission case, facing the cutout portion of the O/D case to the down side of the transmission case.

HINT: Make sure that the oil hole of the O/D case is aligned with the oil hole of the transmission case.

- (b) Using a dial indicator, measure the O/D brake piston stroke while applying and releasing compressed air (392-785 kPa, 4-8 kgf/cm², 57-114 psi)

Piston stroke:

0.65-2.21 mm (0.0256-0.0870 in.)

If the values are non-standard, inspect the discs.

- (c) Remove the O/D case from the transmission case.

AT-40

AUTOMATIC TRANSMISSION - OVERDRIVE BRAKE

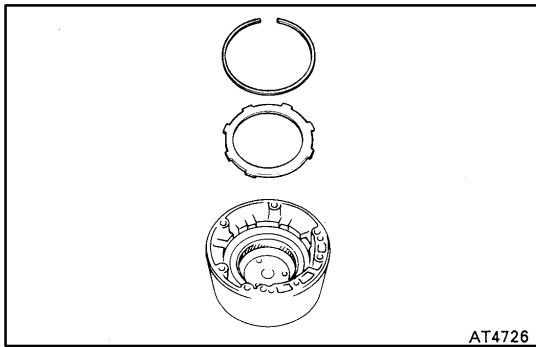

2. REMOVE FLANGE, DISCS, PLATES AND CUSHION PLATE

- (a) Using a screwdriver, remove the snap ring.
- (b) Remove the flange.

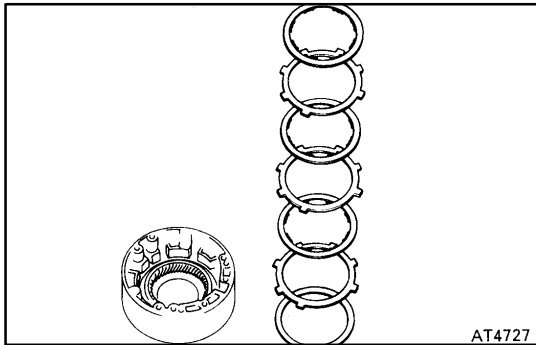

- (c) Remove the 3 discs and 3 plates.
- (d) Remove the cushion plate.

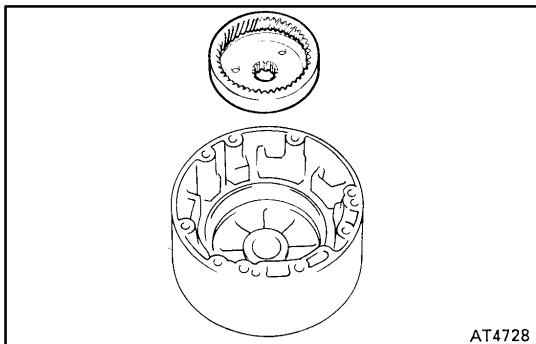

3. REMOVE OVERDRIVE PLANETARY RING GEAR

- (a) Remove the O/D planetary ring gear.

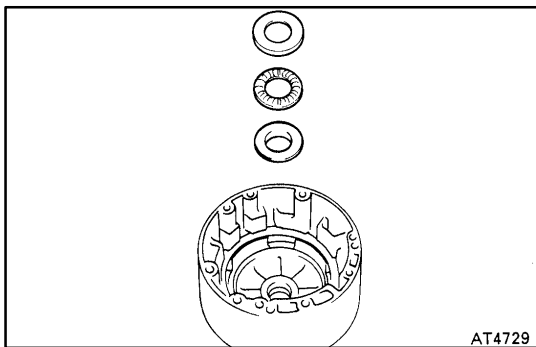

- (b) Remove the bearing and 2 races.

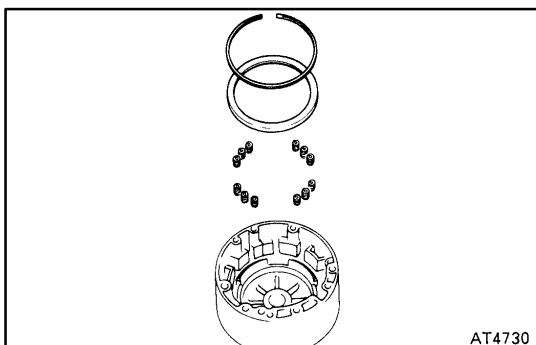

4. REMOVE PISTON RETURN SPRINGS

- (a) Using a screwdriver, remove the snap ring.
- (b) Remove the spring seat and 12 springs.

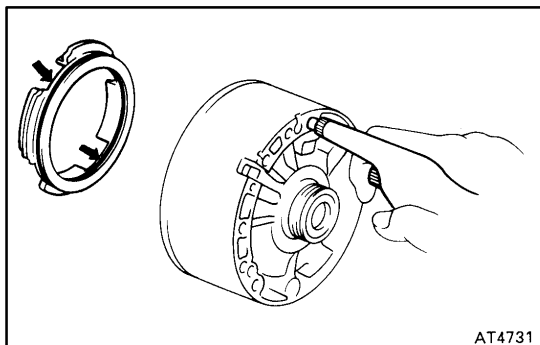

AT4731

5. REMOVE OVERDRIVE BRAKE PISTON

- (a) Hold the O/D brake piston by hand, apply compressed air into the passage to remove the O/D brake piston.
- (c) Remove the 2 O-rings from the piston.

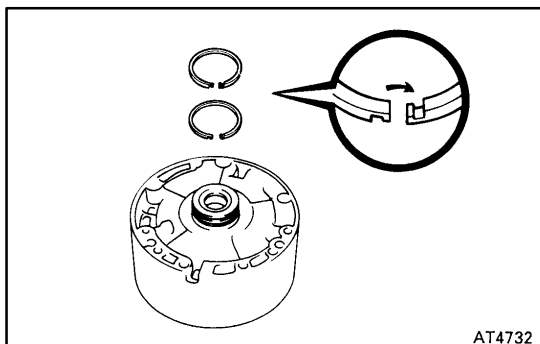

AT4732

6. REMOVE OIL SEAL RINGS

Remove the 2 oil seal rings.

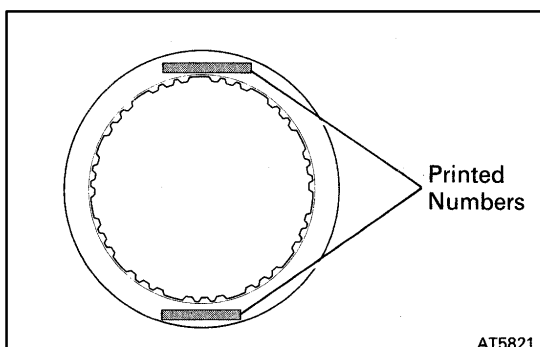

AT5821

OVERDRIVE BRAKE INSPECTION

ATOAG-03

INSPECT DISC, PLATE AND FLANGE

Check to see if the sliding surface of the disc, plate and flange are worn or burnt. If necessary, replace them.

HINT:

- ★ If the lining of the disc is peeling off or discolored, or even if a parts of the printed numbers are defaced, replace all discs.
- ★ Before assembling new discs, soak them in ATF for at least 15 minutes.

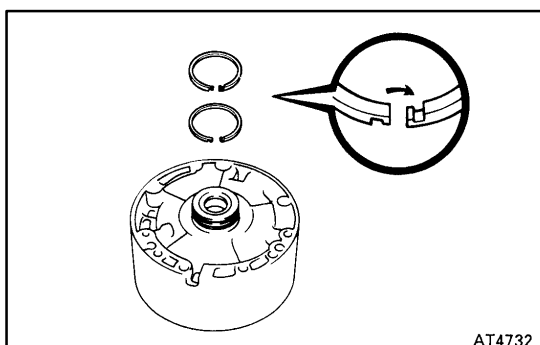

AT4732

OVERDRIVE BRAKE ASSEMBLY

ATOAR-02

1. INSTALL OIL SEAL RINGS

- (a) Coat the 2 oil seal rings with ATF.
- (b) Install 2 oil seal rings to the O/D case, then snug them down by squeezing their ends together.

NOTICE: Do not spread the ring ends more than necessary.

HINT: After installing the oil seal rings, check that they rotate smoothly.

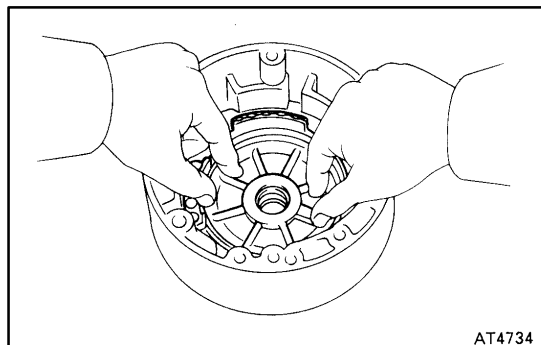

2. INSTALL OVERDRIVE BRAKE PISTON

- (a) Coat 2 new O-rings with ATF and install them on the O/D brake piston.
- (b) Being careful not to damage the O-rings, press in the brake piston into the O/D case with both hands.

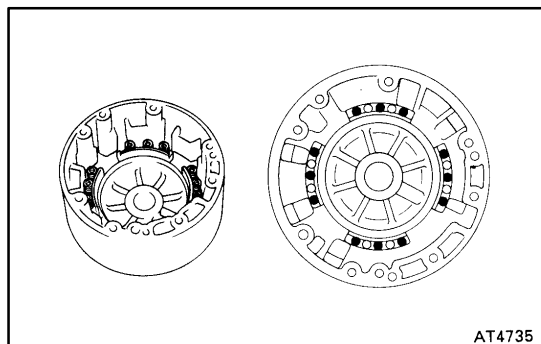

3. INSTALL PISTON RETURN SPRINGS

- (a) Install the 12 piston return springs, as shown.

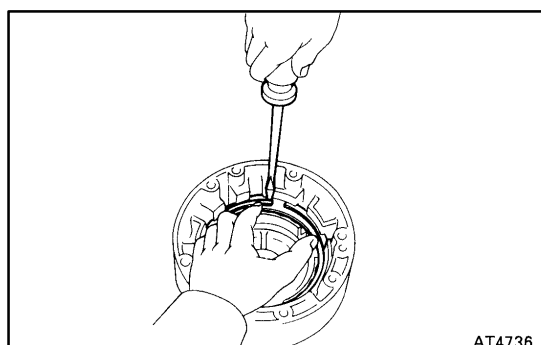

- (b) Install the spring seat.
- (c) Pushing the spring seat, install the snap ring. Be sure the end gap of the snap ring is not aligned with the cutout portion of the O/D case.

HINT: Make sure that the snap ring is inserted in its groove.

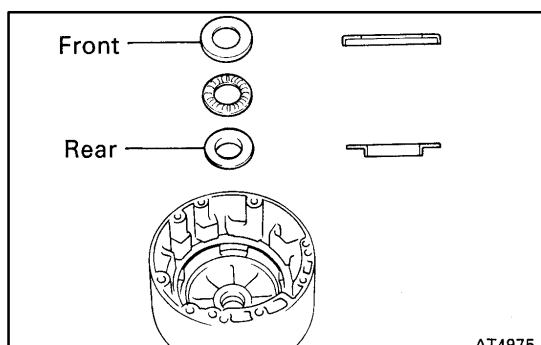

4. INSTALL OVERDRIVE PLANETARY RING GEAR

- (a) Coat the bearing and races with petroleum jelly and install them onto the overdrive case.

Bearing and races diameter
mm (in.)

	Inside	Outside
Race (Front)	30.1 (1.185)	48.5 (1.909)
Bearing	28.4 (1.118)	46.3 (1.823)
Race (Rear)	27.6 (1.087)	44.5 (1.752)

- (b) Install the O/D planetary ring gear.

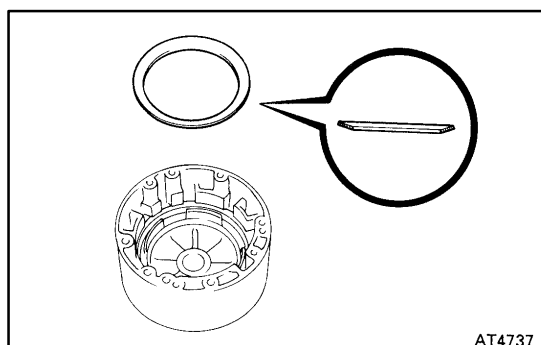

5. INSTALL CUSHION PLATE

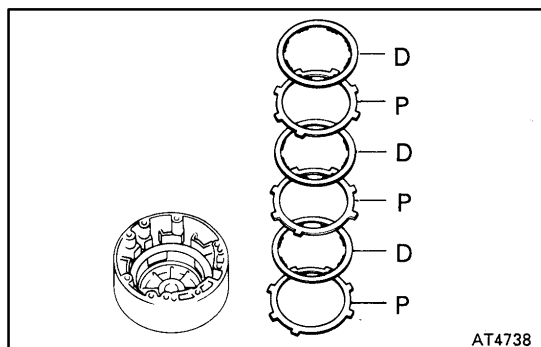

6. INSTALL PLATES AND DISCS

Install the 3 plates and 3 discs.
Install in order: P=Plate D=Disc
P-D-P-D-P-D

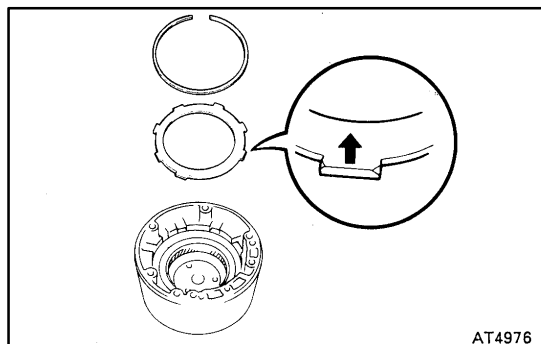

7. INSTALL FLANGE

- (a) Install the flange, the rounded edge facing upward.
- (b) Using a screwdriver, install the snap ring. Be sure the end gap of the snap ring is not aligned with the cutout portion of the O/D case.

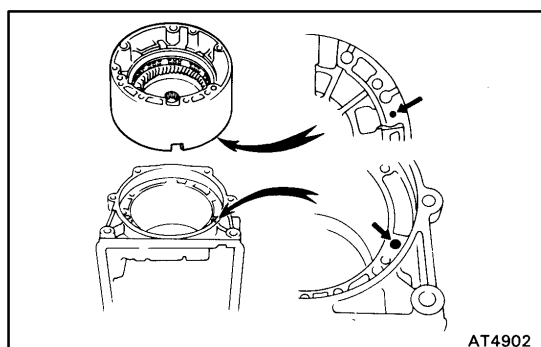

8. CHECK PISTON STROKE OF OVERDRIVE BRAKE

- (a) Place the O/D case assembly onto the transmission case, facing the cutout portion of the O/D case to the down side of the transmission case.
HINT: Make sure that the oil hole of the O/D case is aligned with the oil hole of the transmission case.

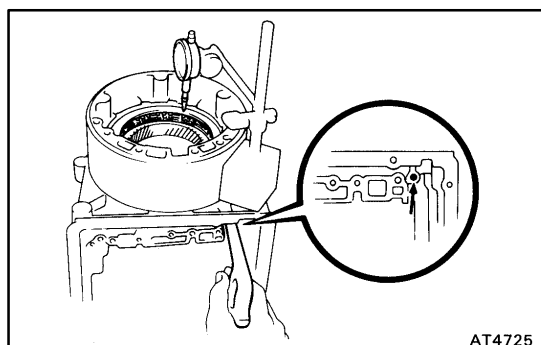

- (b) Using a dial indicator, measure the O/D brake piston stroke while applying and releasing compressed air (392-785 kPa, 4-8 kgf/cm², 57-114 psi)

Piston stroke:

0.65-2.21 mm (0.0256-0.0870 in.)

If the piston stroke is less than the limit, parts may have been assembled incorrectly, check and reassemble again.

FRONT CLUTCH COMPONENTS

ATOAS-03

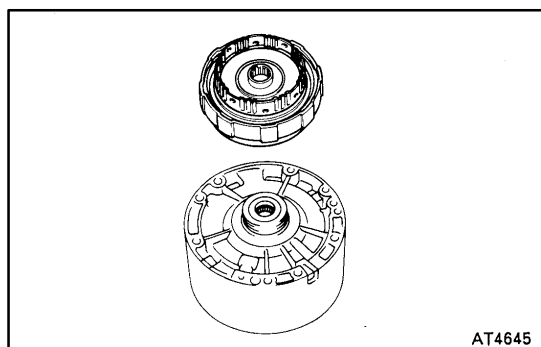
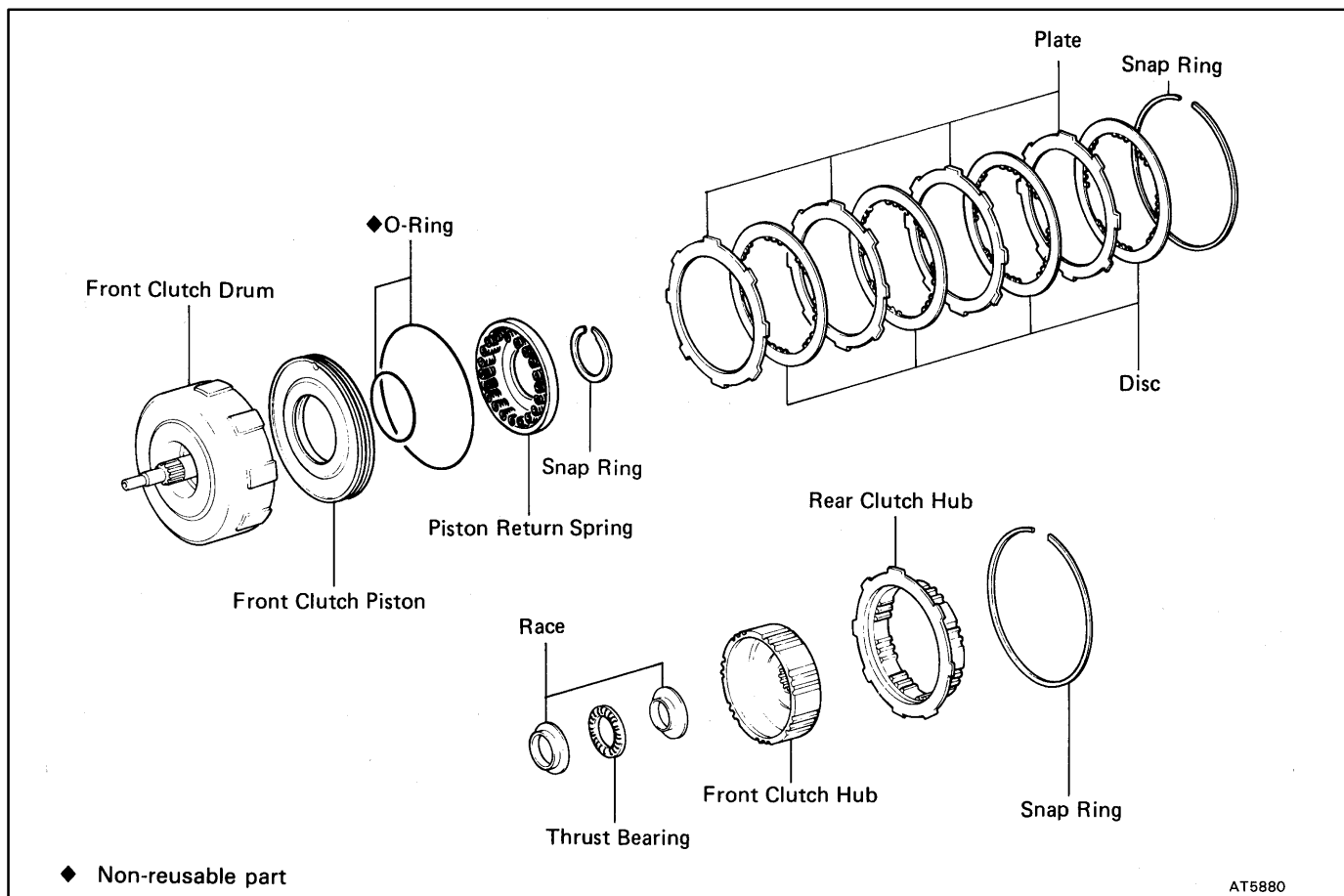

FRONT CLUTCH DISASSEMBLY

ATOAT-03

1. INSTALL FRONT CLUTCH ASSEMBLY TO OVER-DRIVE CASE

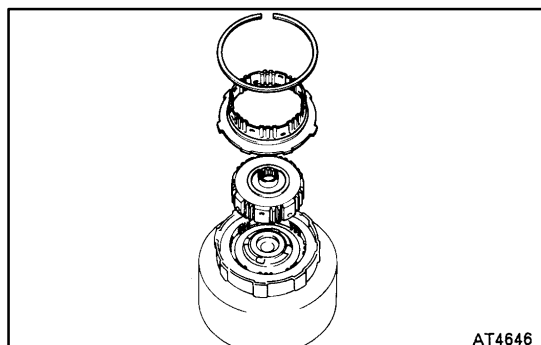

2. REMOVE REAR CLUTCH HUB AND FRONT CLUTCH HUB
 - (a) Using a screwdriver, remove the snap ring.
 - (b) Remove the rear clutch hub and front clutch hub.

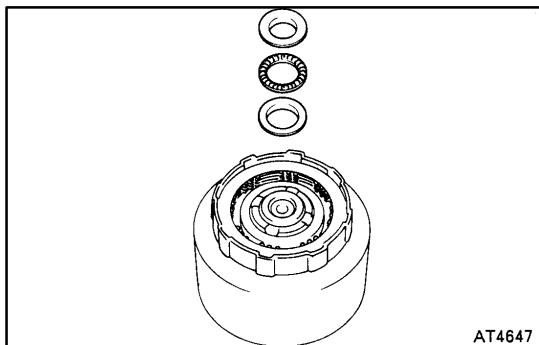

(c) Remove the bearing and 2 races.

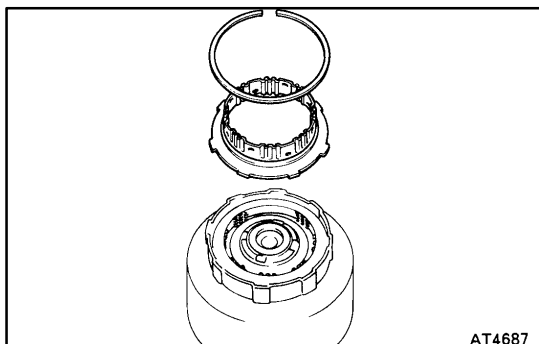

3. CHECK PISTON STROKE OF FRONT CLUTCH

- (a) Before checking the piston stroke, install the rear clutch hub.
- (b) Install the snap ring.

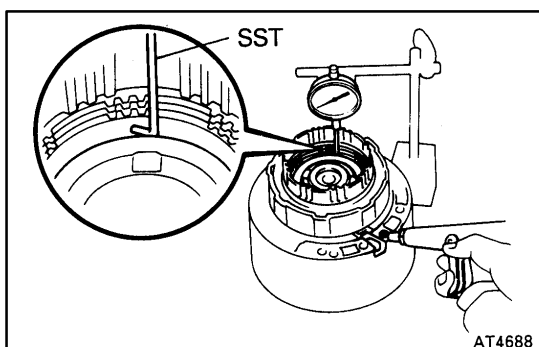

- (c) Using SST and a dial indicator, measure the front clutch piston stroke while applying and releasing compressed air (392-785 kPa, 4-8 kgf/cm², 57-114 psi).
SST 09350-20015 (09350-06120)

Piston stroke:

1.32-2.66 mm (0.0520-0.1047 in.)

If the values are non-standard, inspect the discs.

- (d) Remove the snap ring and rear clutch hub.

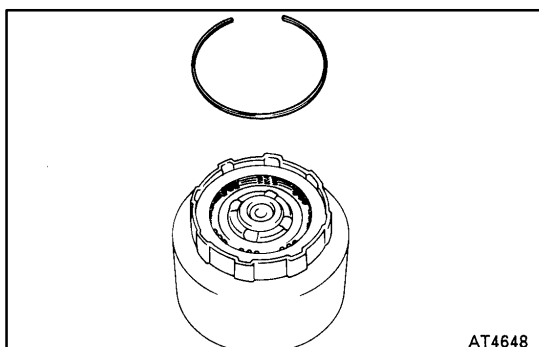

4. REMOVE DISCS AND PLATES

- (a) Using a screwdriver, remove the snap ring.

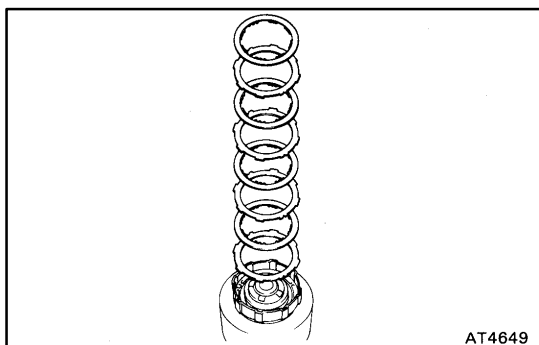

- (d) Remove the 4 discs and 4 plates.

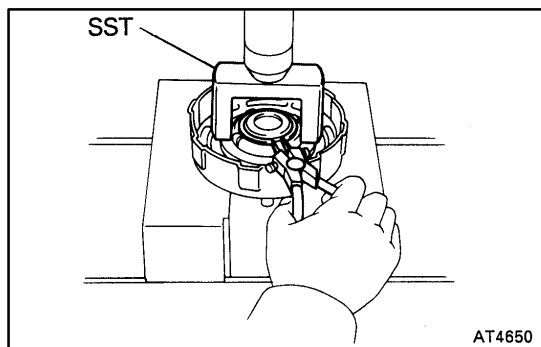

5. REMOVE PISTON RETURN SPRINGS

- (a) Place SST on the spring seat and compress the return springs with a shop press.
SST 09350-20015 (09369-20040)
- (b) Using a snap ring expander, remove the snap ring.

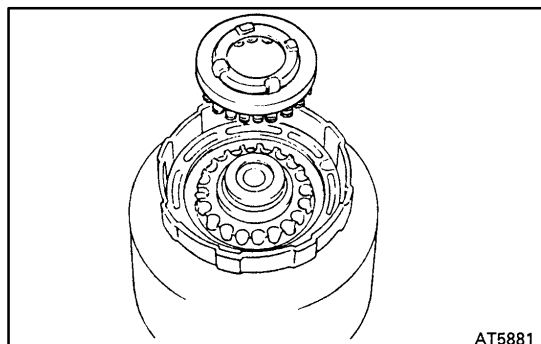

- (c) Remove the piston return spring.

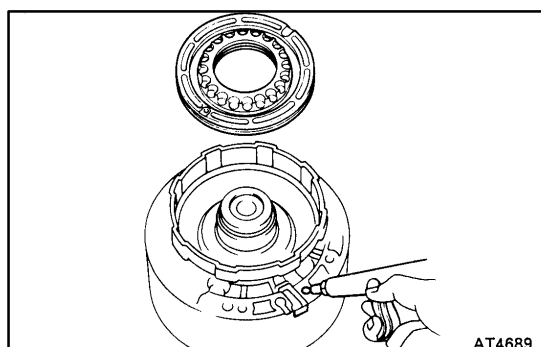

6. REMOVE FRONT CLUTCH PISTON

- (a) Place the front clutch drum onto the O/D case.
- (d) Hold the front clutch piston with hand, apply compressed air to the O/D case to remove the front clutch piston.
- (c) Remove the 2 O-rings from the piston.

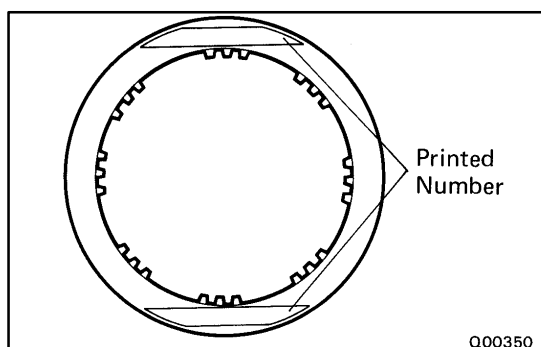

FRONT CLUTCH INSPECTION

AT0AU-03

1. INSPECT DISC AND PLATE

Check to see if the sliding surface of the disc and plate are worn or burnt. If necessary, replace them.

HINT:

- ★ If the lining of the disc is peeling off or discolored, or even if a parts of the printed numbers are defaced, replace all discs.
- ★ Before assembling new discs. soak them in ATF for at least 15 minutes.

2. CHECK FRONT CLUTCH PISTON

- (a) Check that check ball is free by shaking the piston.
- (b) Check that the valve does not leak by applying low pressure compressed air.

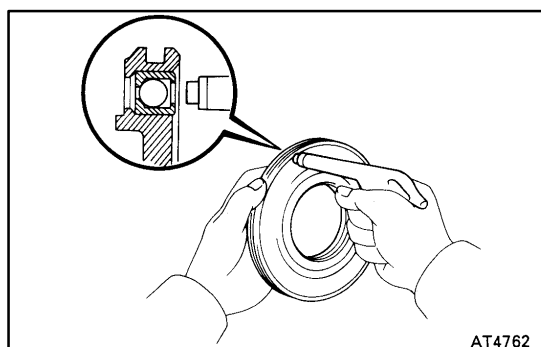

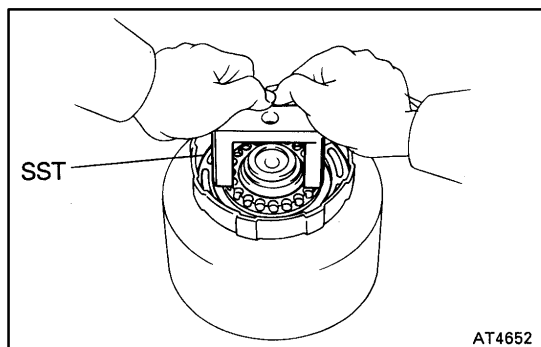

FRONT CLUTCH ASSEMBLY

1. INSTALL FRONT CLUTCH PISTON

- (a) Coat new O-rings with ATF and install them on the front clutch piston.
- (b) Place SST on the front clutch piston.
SST 09350-20015 (09369-20040)
- (c) Being careful not to damage the O-rings, press the clutch piston into the front clutch drum with both hands.

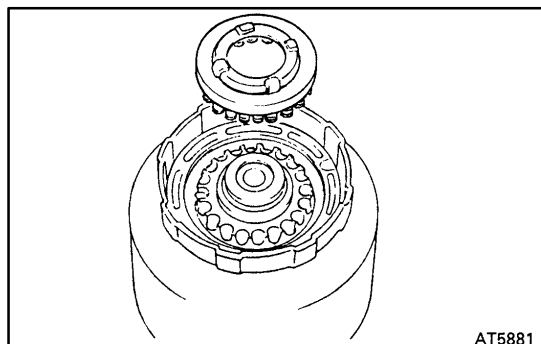

2. INSTALL PISTON RETURN SPRING

- (a) Install the piston return spring.

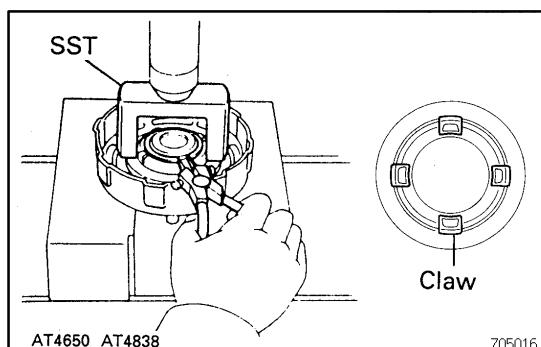

- (b) Place SST on the spring seat, and compress the return springs with a shop press.
SST 09350-20015 (09369-20040)
- (c) Install the snap ring with a snap ring expander. Be sure the end gap of the snap ring is not aligned with the spring seat claw.

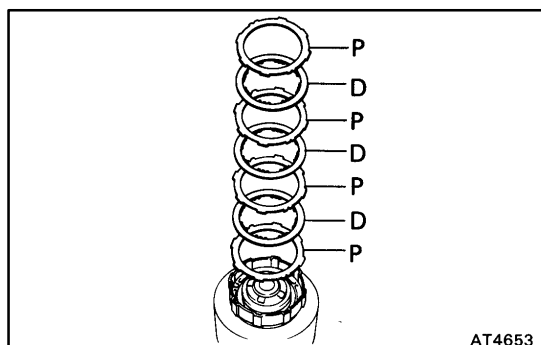

3. INSTALL PLATES AND DISCS

- (a) Install the 4 plates and 3 discs.
Install in order: P=Plate D= Disc
P-D-P-D-P-D-P

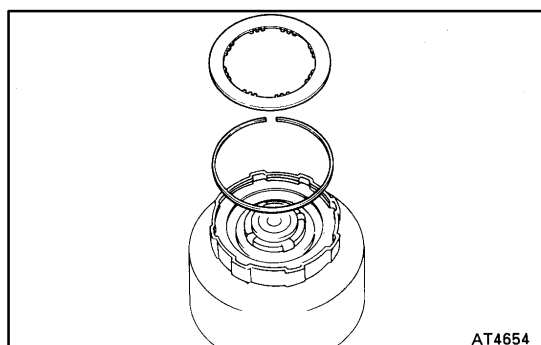

- (b) Install the snap ring. Be sure the end gap of the snap ring is not aligned with the cutout portion of the front clutch drum.
- (c) Install the disc.

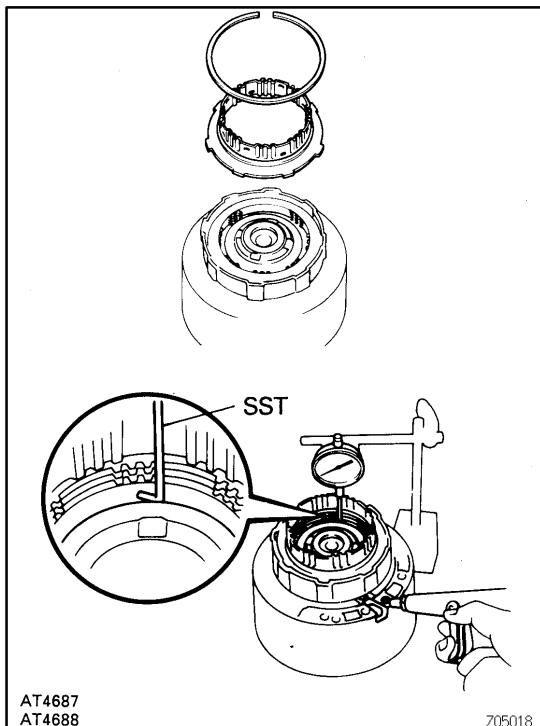

4. CHECK PISTON STROKE OF FRONT CLUTCH

- (a) Before checking the piston stroke, install the rear clutch hub.
- (b) Install the snap ring.
- (c) Using SST and a dial indicator, measure the front clutch piston stroke while applying and releasing compressed air (392-785 kPa, 4-8 kgf/cm², 57-114 psi).

SST 09350-20015 (09350-06120)

Piston stroke:

1.32-2.66 mm (0.0520-0.1047 in.)

If the piston stroke is less than the limit, parts may have been assembled incorrectly, check and reassemble again.

If the piston stroke is nonstandard, select another plate.
HINT: There are 2 different thicknesses for the plate.

Plate thickness

1.8 mm (0.071 in.)	2.0 mm (0.079 in.)
--------------------	--------------------

- (d) Remove the snap ring and rear clutch hub.

5. INSTALL FRONT CLUTCH HUB

- (a) Coat the bearing and races with petroleum jelly and install them onto the front clutch drum.

Bearing and races diameter

mm (in.)

	Inside	Outside
Race (Rear)	21.4 (0.843)	37.3 (1.469)
Bearing	23.4 (0.921)	37.5 (1.476)
Race (Front)	24.1 (0.949)	37.3 (1.469)

- (b) Install the front clutch hub into the front clutch drum.
HINT: Mesh the splines of the front clutch hub with the flukes of the discs by rotating and pushing the front clutch hub.

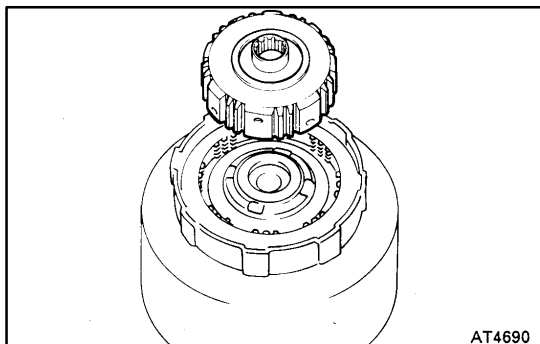
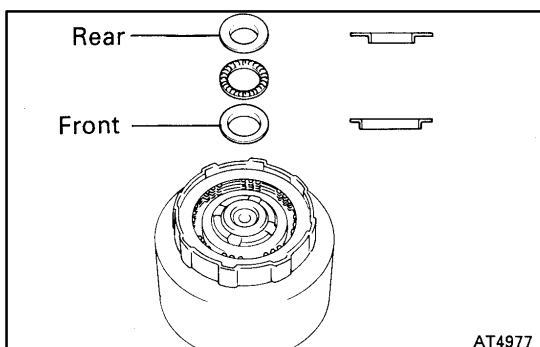

6. INSTALL REAR CLUTCH HUB

- (a) Install the rear clutch hub.
- (b) Install the snap ring. Be sure the end gap of the snap ring is not aligned with the cutout portion of the front clutch drum.

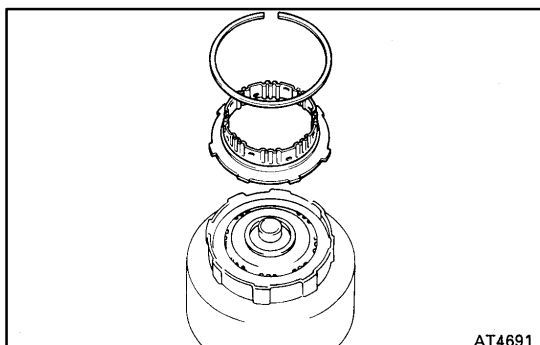

REAR CLUTCH COMPONENTS

AT0AW-03

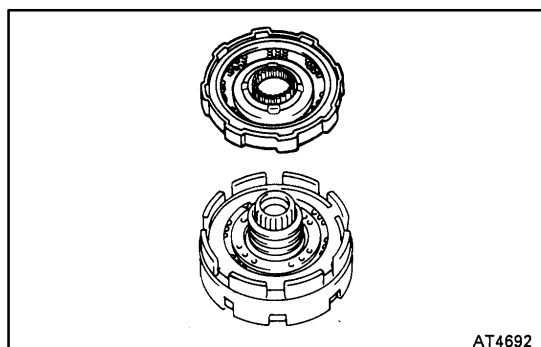
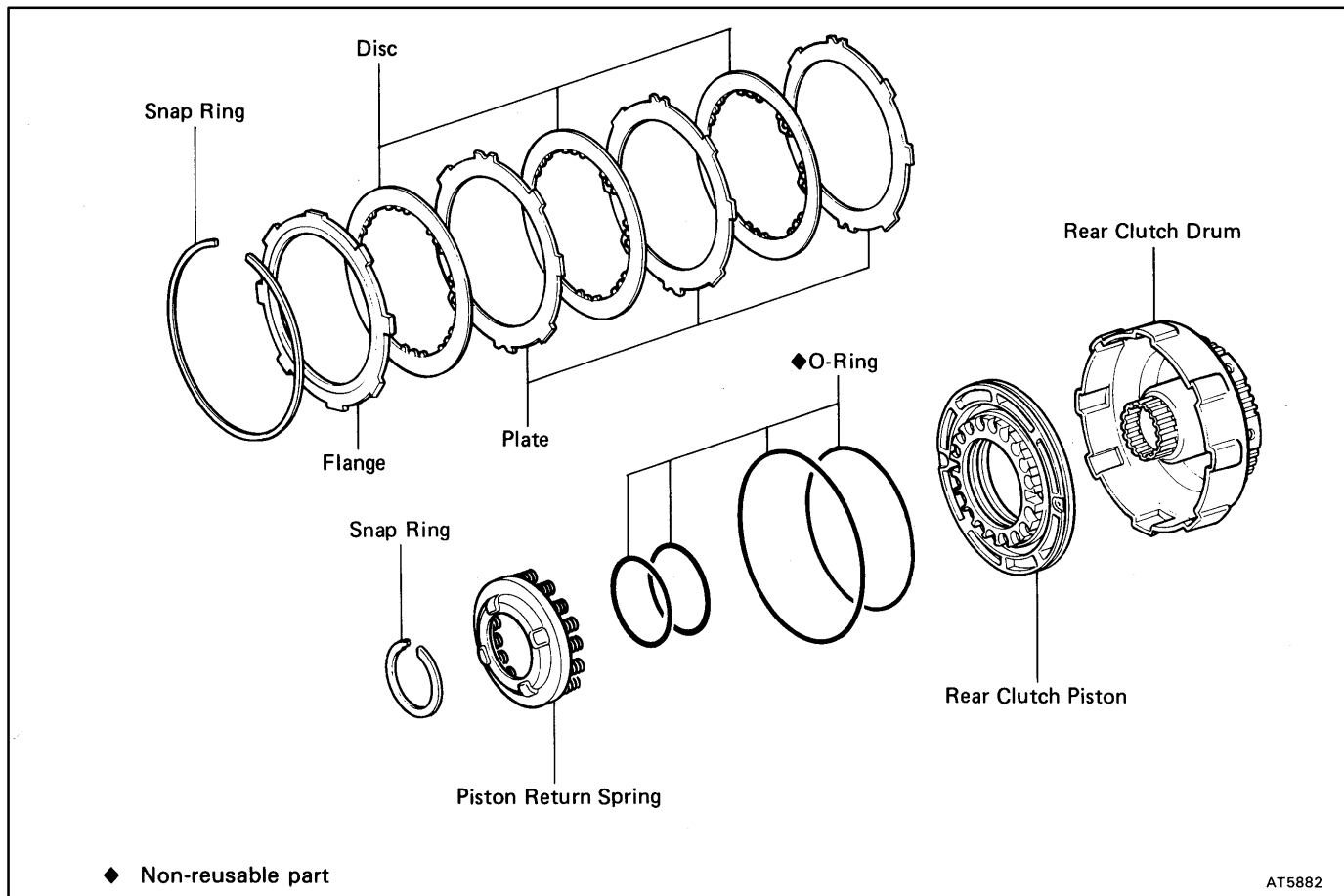

REAR CLUTCH DISASSEMBLY

AT0AX-02

1. CHECK PISTON STROKE OF REAR CLUTCH

(a) Place the rear clutch assembly onto the center support.

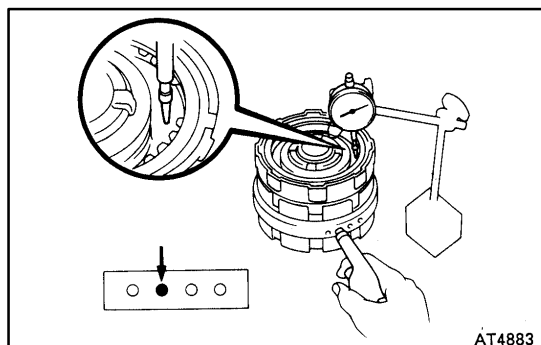

(b) Using a dial indicator, measure the rear clutch piston stroke while applying and releasing compressed air (392-785 kPa, 4-8 kgf/cm², 57-114 psi).

Piston stroke:

0.91-1.99 mm (0.0358-0.0783 in.)

If the values are non-standard, inspect the discs.

AT-50

AUTOMATIC TRANSMISSION - REAR CLUTCH

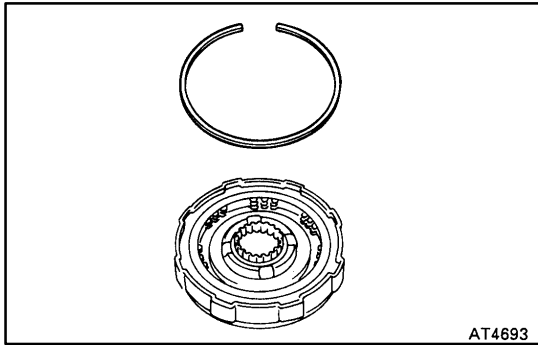

2. REMOVE FLANGE

(a) Using a screwdriver, remove the snap ring.

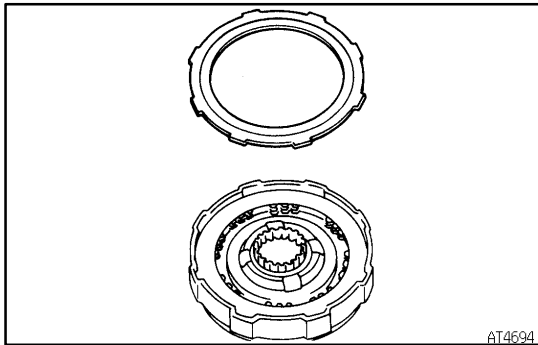

(b) Remove the flange.

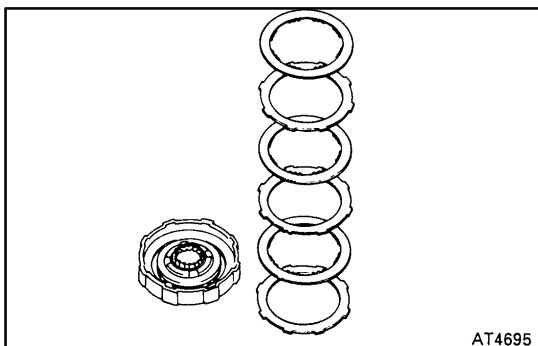

3. REMOVE DISCS AND PLATES

Remove the 3 discs and 3 plates.

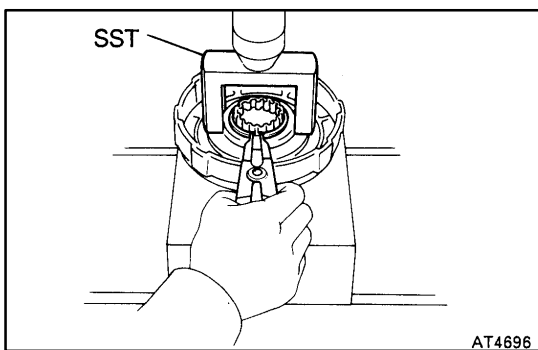

4. REMOVE PISTON RETURN SPRINGS

(a) Place SST on the spring seat and compress the return springs with a shop press.

SST 09350-20015 (09369-20040)

(b) Using a snap ring expander, remove the snap ring.

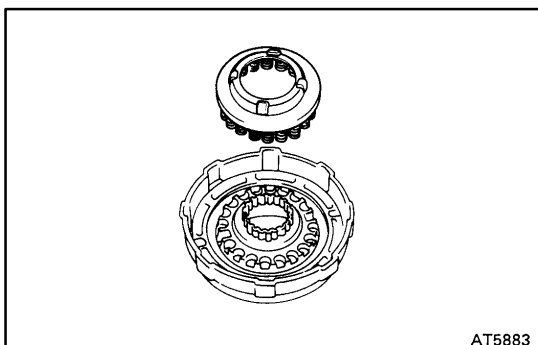

(c) Remove the piston return spring.

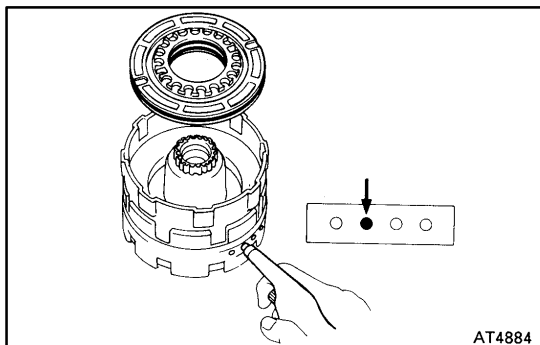

5. REMOVE REAR CLUTCH PISTON

- (a) Place the rear clutch drum onto the center support.
- (b) Hold the rear clutch piston with hand, apply compressed air to the center support to remove the rear clutch piston.
- (c) Remove the 4 O-rings from the piston.

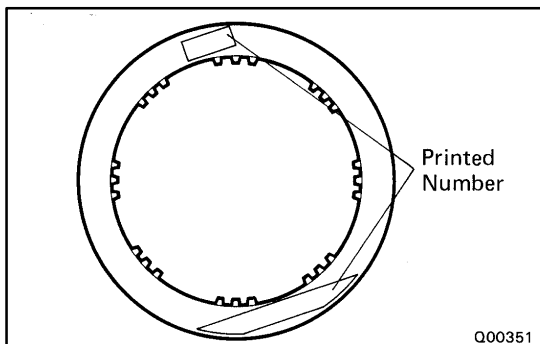

REAR CLUTCH INSPECTION

AT04Y-03

1. INSPECT DISC, PLATE AND FLANGE

Check to see if the sliding surface of the disc, plate and flange are worn or burnt. If necessary, replace them.

HINT:

- ★ If the lining of the disc is peeling off or discolored, or even if a parts of the printed numbers are defaced, replace all discs.
- ★ Before assembling new discs, soak them in ATF for at least 15 minutes.

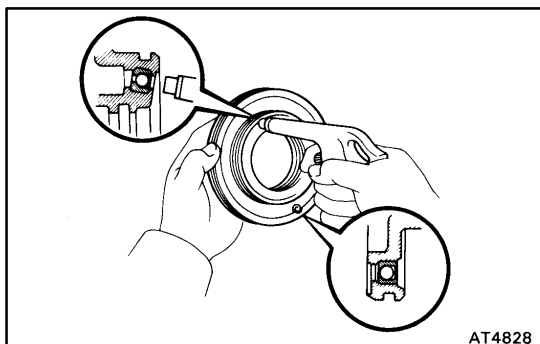

2. CHECK REAR CLUTCH PISTON

- (a) Check that check balls are free by shaking the piston.
- (b) Check that the valves do not leak by applying low-pressure compressed air.

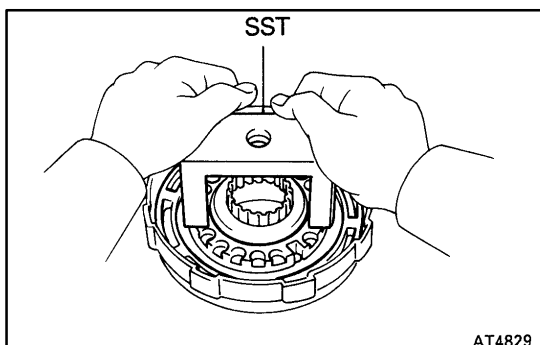

REAR CLUTCH ASSEMBLY

AT0AZ-02

1. INSTALL REAR CLUTCH PISTON

- (a) Coat new O-rings with ATF and install them on the rear clutch piston.
- (b) Place SST on the rear clutch piston.
SST 09350-20015 (09369-20040)
- (c) Being careful not to damage the O-rings, press in the rear clutch piston into the clutch drum with both hands.

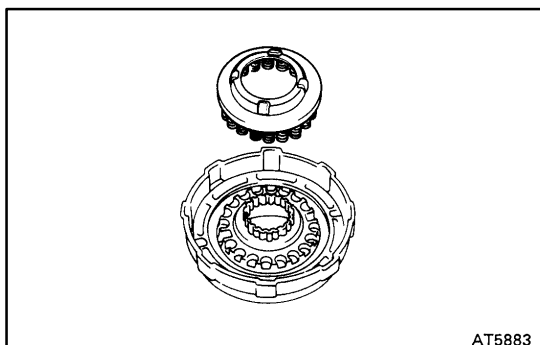

2. INSTALL PISTON RETURN SPRINGS

- (a) Install the piston return spring.

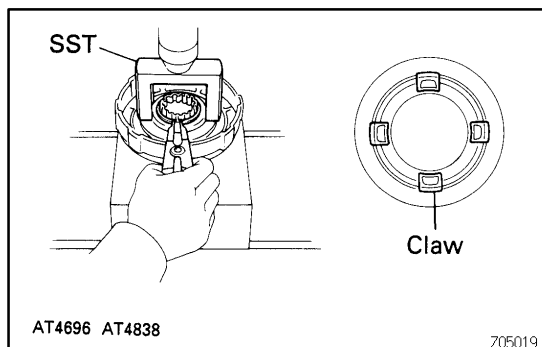

- (b) Place SST on the spring seat, and compress the return springs with a shop press.
SST 09350-20015 (09369-20040)
- (c) Install the snap ring with a snap ring expander. Be sure the end gap of the snap ring is not aligned with the spring seat claw.

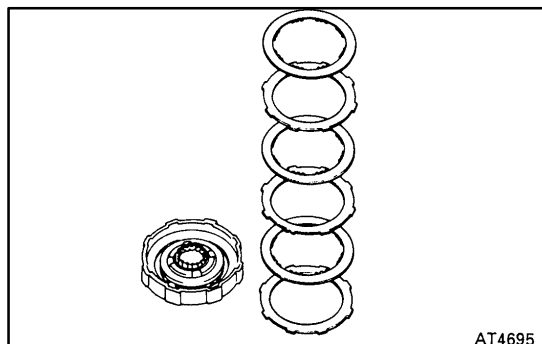

3. INSTALL PLATES AND DISCS

Install the 3 plates and 3 discs.
Install in order: P=Plate D=Disc
P-D-P-D-P-D

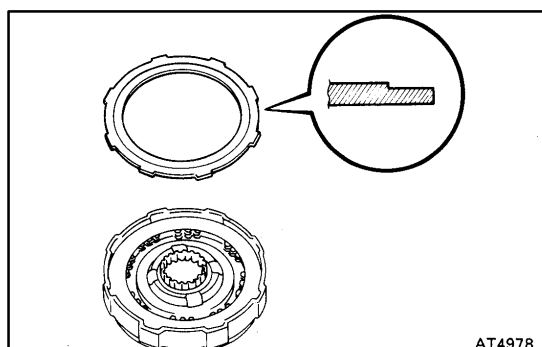

4. INSTALL FLANGE

- (a) Install the flange, the flat end facing downward.

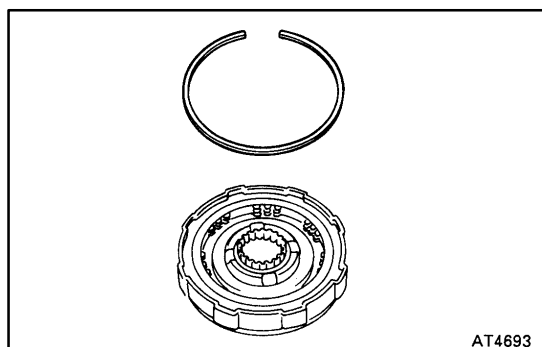

- (b) Using a screwdriver, install the snap ring. Be sure the end gap of the snap ring is not aligned with the cutout portion of the rear clutch drum.

5. CHECK PISTON STROKE OF REAR CLUTCH

- (a) Plate the rear clutch assembly onto the center support.
- (b) Using a dial indicator, measure the rear clutch piston stroke while applying and releasing compressed air (392-785 kPa, 4-8 kgf/cm², 57-114 psi).

Piston stroke:

0.91-1.99 mm (0.0358-0.0783 in.)

If the piston stroke is less than the limit, parts may have been assembled incorrectly, check and reassemble again.

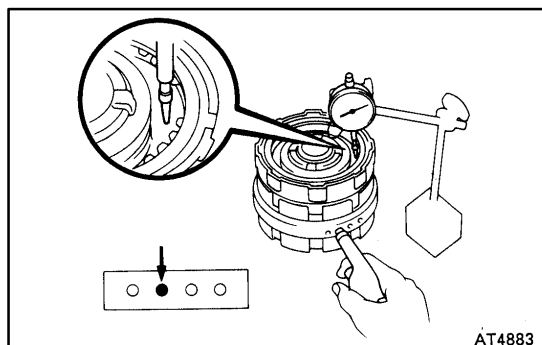

NO.1 BRAKE COMPONENTS

AT0B0-03

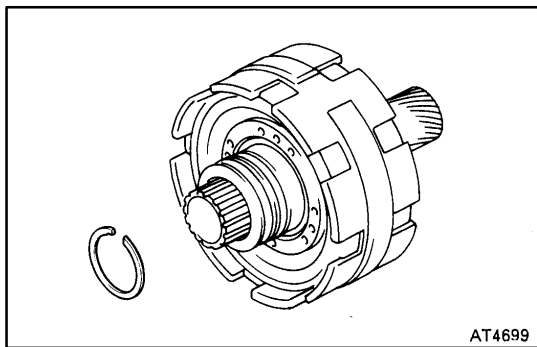
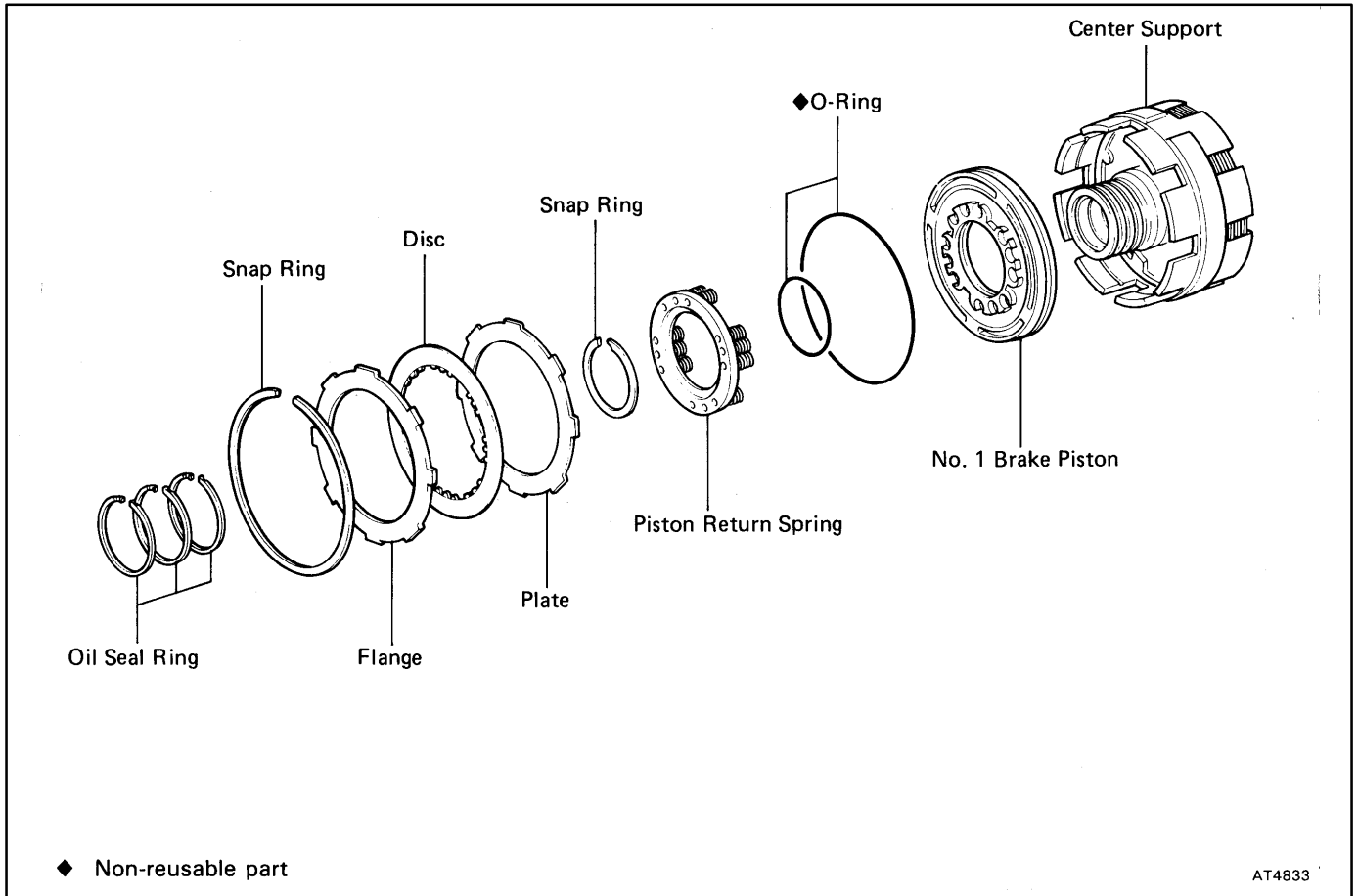

NO.1 BRAKE DISASSEMBLY

AT0B1-03

1. REMOVE PLANETARY SUN GEAR AND NO.1 ONE-WAY CLUTCH

(a) Using a snap ring expander, remove the snap ring.

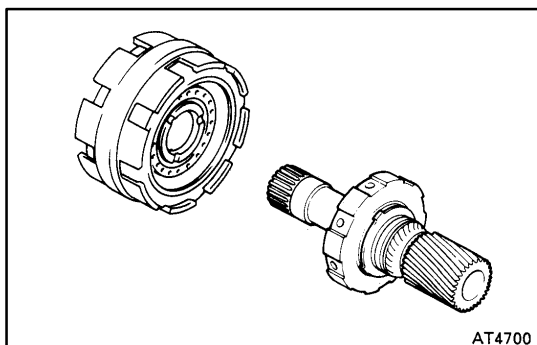

(b) Remove the planetary sun gear with No.1 one-way clutch.

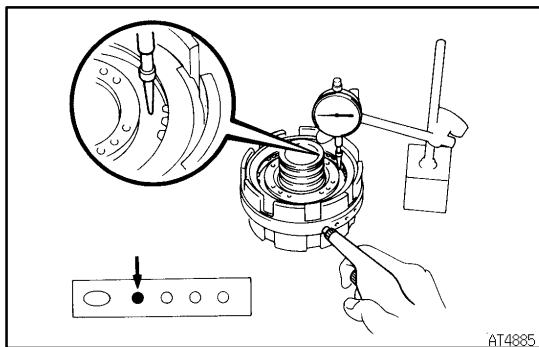

2. CHECK PISTON STROKE OF NO.1 BRAKE

Using a dial indicator, measure the No.1 brake piston stroke while applying and releasing compressed air (392-785 kPa, 4-8 kgf/cm², 57-114 psi).

Piston stroke:

0.78-1.50 mm (0.0307-0.0591 in.)

If the values are non-standard, inspect the disc.

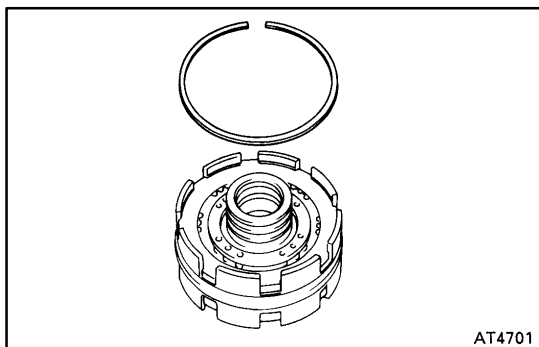

3. REMOVE FLANGE

(a) Using a screwdriver, remove the snap ring.

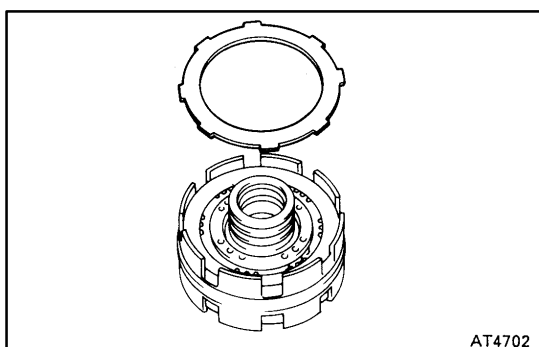

(b) Remove the flange.

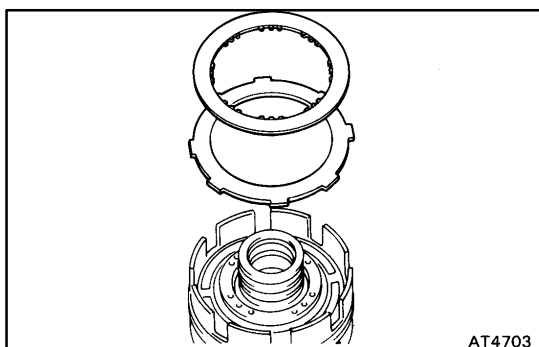

4. REMOVE DISC AND PLATE

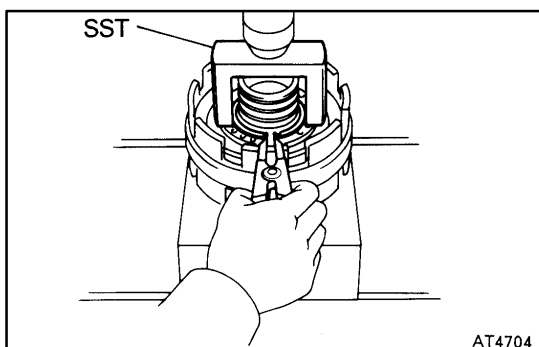

5. REMOVE PISTON RETURN SPRING

(a) Place SST on the spring seat and compress the return springs with a shop press.

SST 09350-20015 (09369-20040)

(b) Using a snap ring expander, remove the snap ring.

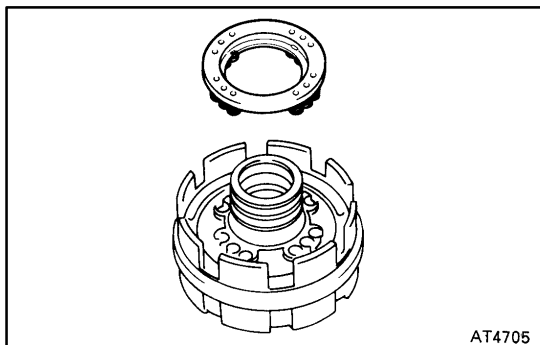

(c) Remove the piston return spring.

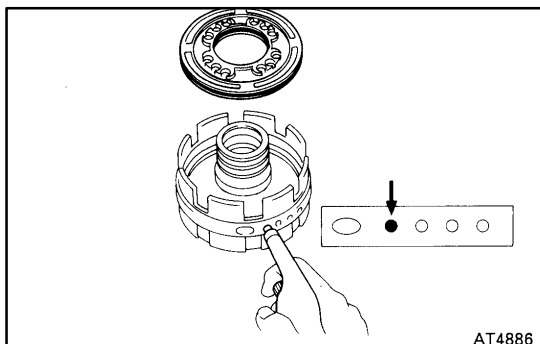

6. REMOVE NO.1 BRAKE PISTON

- (a) Hold the No.1 brake piston with hand, apply compressed air to the center support to remove the No.1 brake piston.
- (b) Remove the 2 O-rings from the piston.

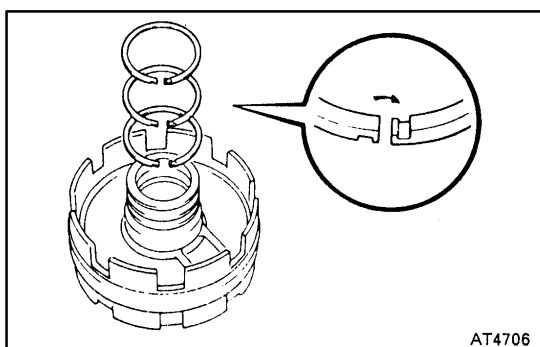

7. REMOVE OIL SEAL RINGS

Remove the 3 oil seal rings.

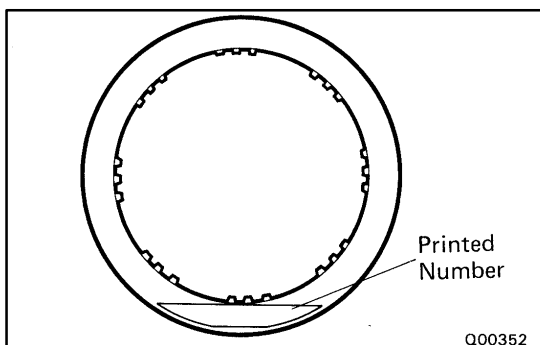

NO.1 BRAKE INSPECTION

AT0B2-03

1. INSPECT DISC, PLATE AND FLANGE

Check to see if the sliding surface of the disc, plate and flange are worn or burnt. If necessary, replace them.

HINT:

- ★ If the lining of the disc is peeling off or discolored, or even if a parts of the printed numbers are defaced, replace disc.
- ★ Before assembling new disc, soak it in ATF for at least 15 minutes.

2. CHECK CENTER SUPPORT BUSHING

Using a dial indicator, measure the inside diameter of the center support bushing.

Maximum inside diameter:

36.46 mm (1.4354 in.)

If the inside diameter is greater than the maximum, replace the center support.

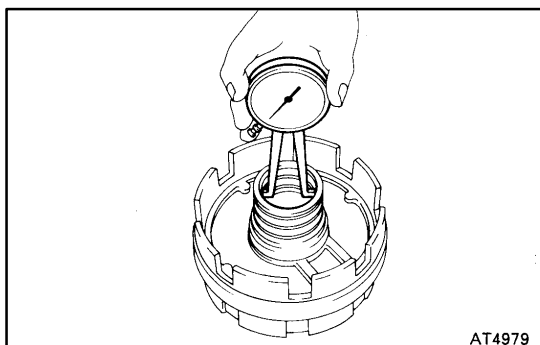

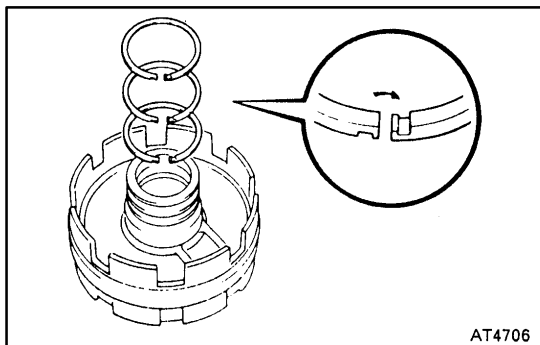

NO.1 BRAKE ASSEMBLY

1. INSTALL OIL SEAL RINGS

- (a) Coat the 3 oil seal rings with ATF.
- (b) Contract the oil seal rings and install them onto the center support.

NOTICE: Do not spread the ring ends too much.

HINT: After installing the oil seal rings, check that they rotate smoothly.

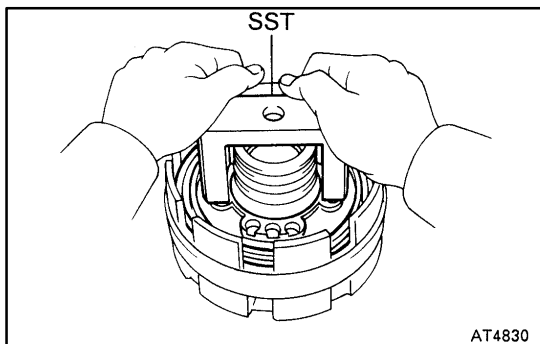

2. INSTALL NO.1 BRAKE PISTON

- (a) Coat new O-rings with ATF and install them on the No.1 brake piston.
- (b) Place SST on the No.1 brake piston.
SST 09350-20015 (09369-20040)
- (c) Being careful not to damage the O-rings, press in the No.1 brake piston into the center support with both hands.

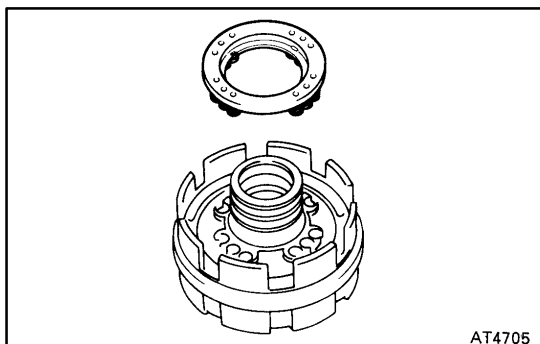

3. INSTALL PISTON RETURN SPRING

- (a) Install the piston return spring.

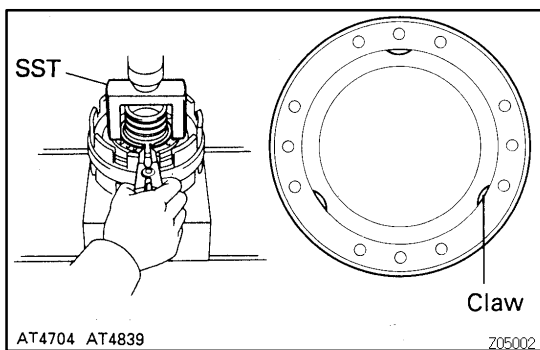

- (b) Place SST on the spring seat, and compress the return springs with a shop press.
SST 09350-20015 (09369-20040)

- (c) Install the snap ring with a snap ring expander. Be sure the end gap of the snap ring is not aligned with the spring seat claw.

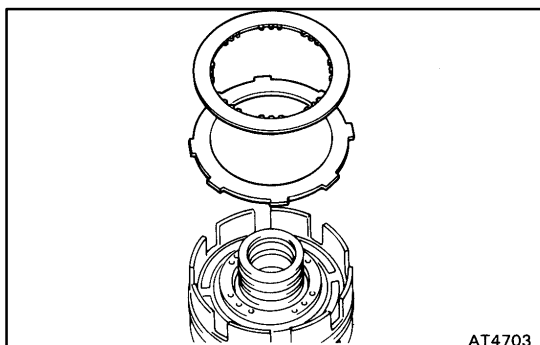

4. INSTALL PLATE AND DISC

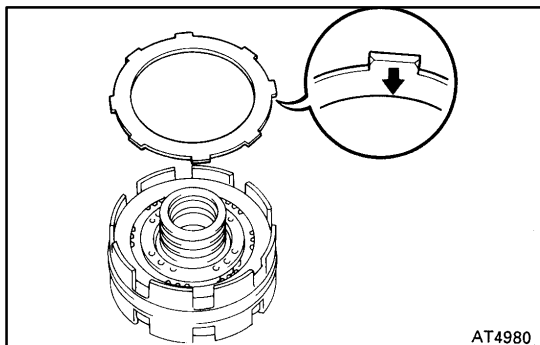

5. INSTALL FLANGE

(a) Install the flange, the rounded edge facing downward.

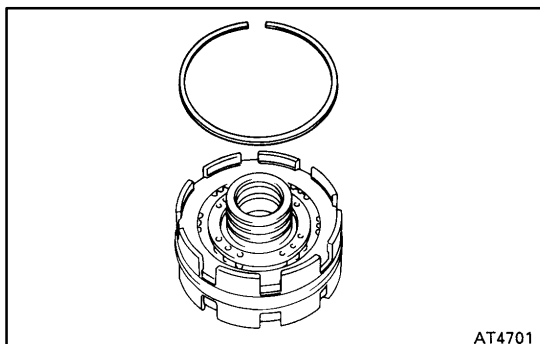

(b) Using a screwdriver, install the snap ring. Be sure the end gap of the snap ring is not aligned with the cutout portion of the center support.

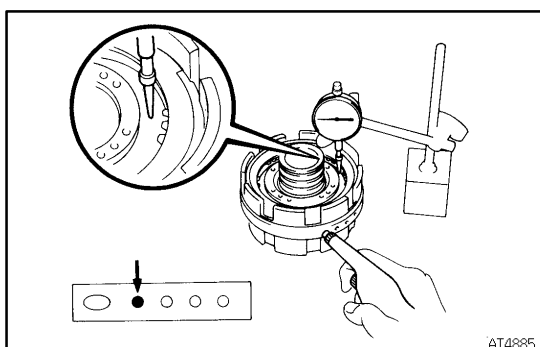

6. CHECK PISTON STROKE OF NO.1 BRAKE

Using a dial indicator, measure the No.1 brake piston stroke while applying and releasing compressed air (392-785 kPa, 4-8 kgf/cm², 57-114 psi).

Piston stroke:

0.78-1.50 mm (0.0307-0.0591 in.)

If the piston stroke is less than the limit, parts may have been assembled incorrectly, check and reassemble again.

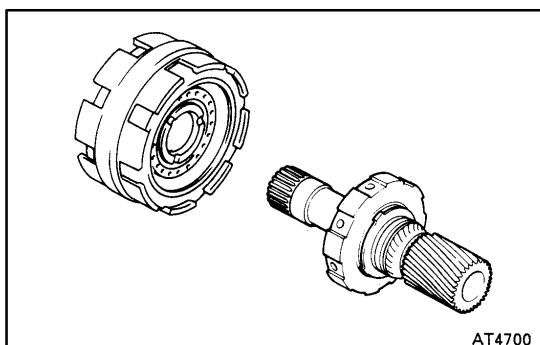

7. INSTALL PLANETARY SUN GEAR AND NO.1 ONE-WAY CLUTCH

(a) While turning the one-way clutch, install the planetary sun gear.

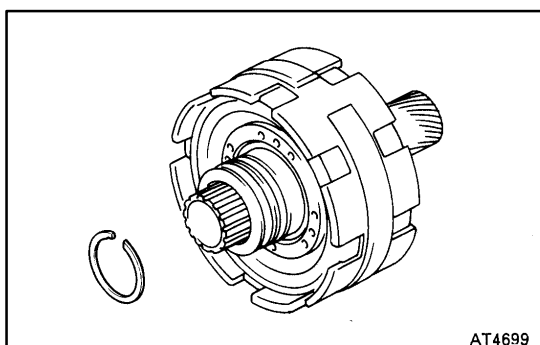

(b) Using a snap ring expander, install the snap ring.

NO.2 BRAKE COMPONENTS

AT0B4-03

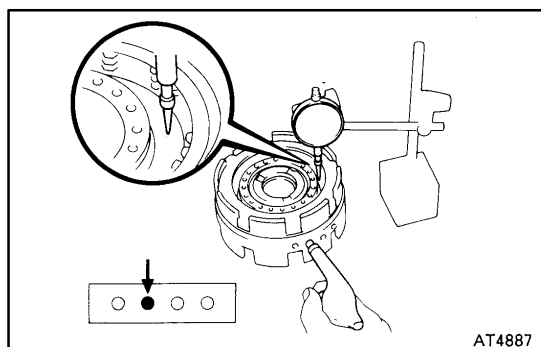
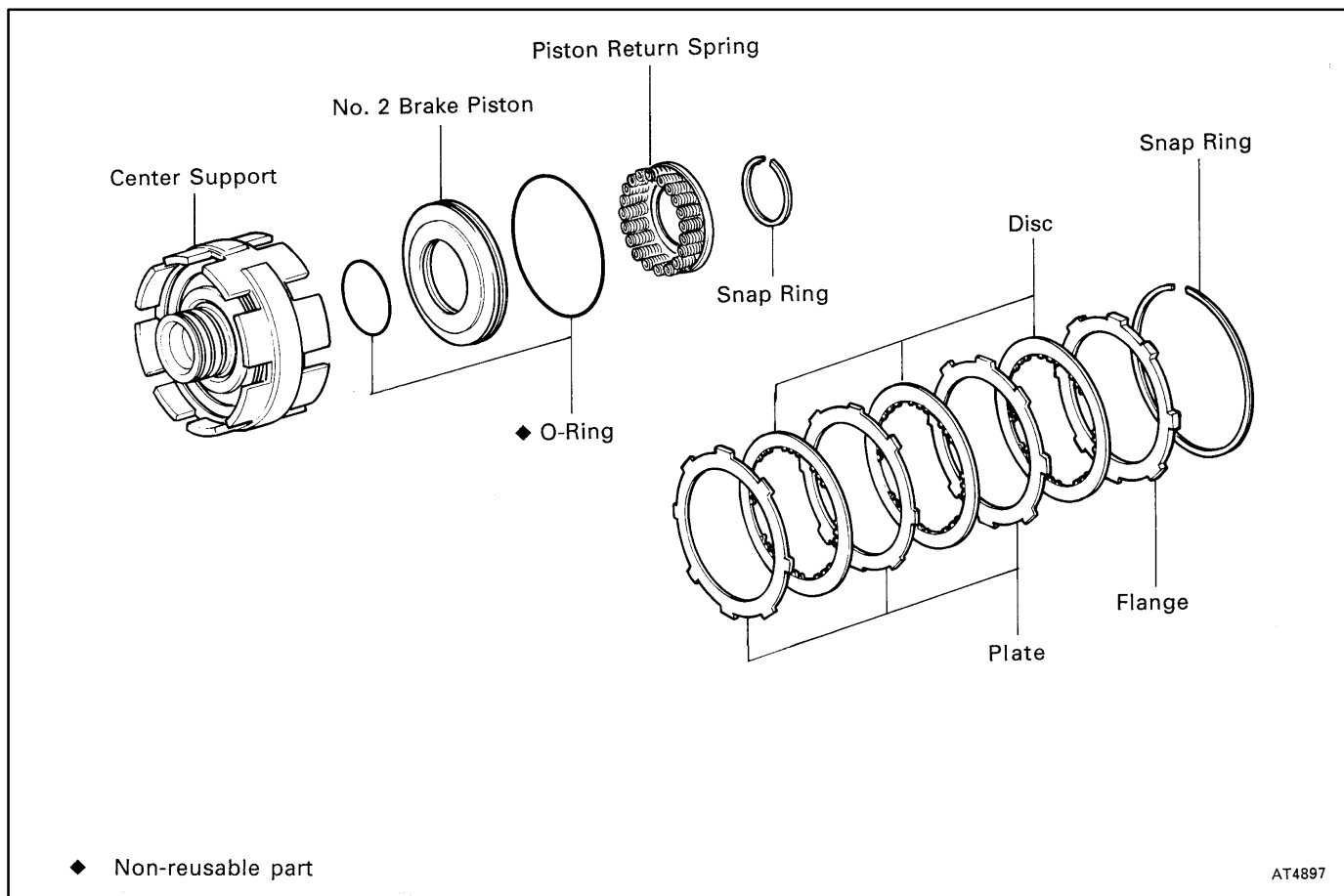

NO.2 BRAKE DISASSEMBLY

AT0B5-03

1. REMOVE PLANETARY SUN GEAR AND NO.1 ONE-WAY CLUTCH

2. CHECK PISTON STROKE OF NO.2 BRAKE

Using a dial indicator, measure the No.2 brake piston stroke while applying and releasing compressed air (392-785 kPa, 4-8 kgf/cm², 57-114 psi).

Piston stroke:

1.01-2.25 mm (0.0398-0.0886 in.)

If the values are non-standard, inspect the discs.

3. REMOVE FLANGE

- (a) Using a screwdriver, remove the snap ring.

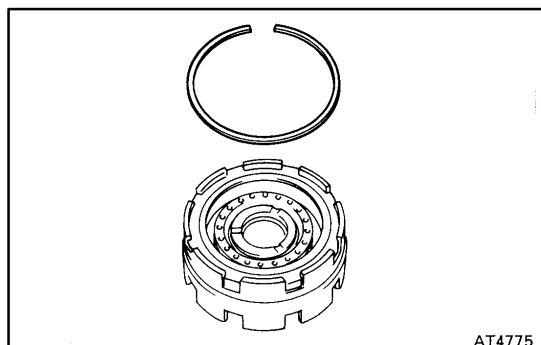

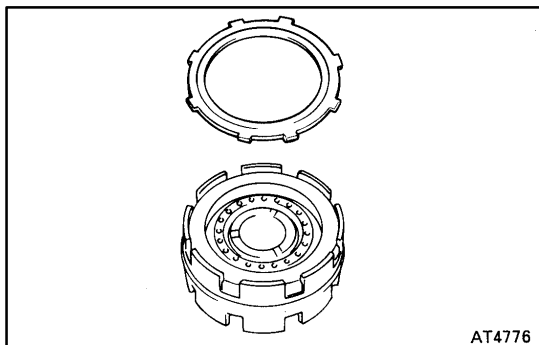

(b) Remove the flange.

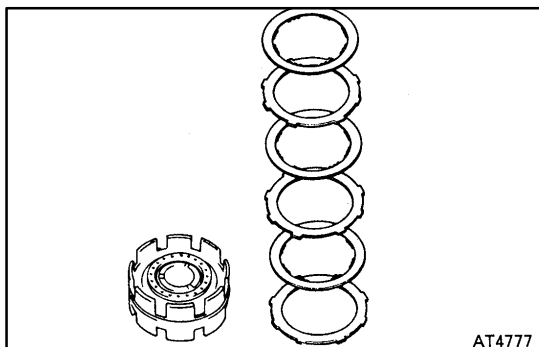

4. REMOVE DISCS AND PLATES
Remove the 3 discs and 3 plates.

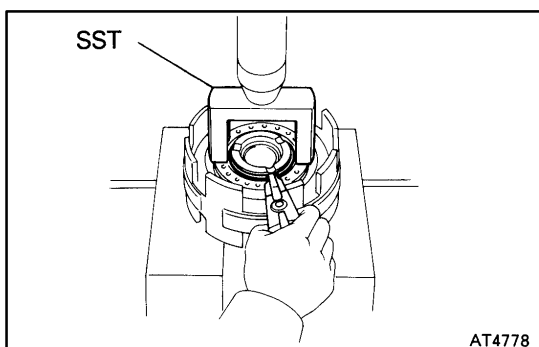

5. REMOVE PISTON RETURN SPRING
(a) Place SST on the spring seat and compress the return springs with a shop press.
SST 09350-20015 (09369-20040)
(b) Using a snap ring expander, remove the snap ring.

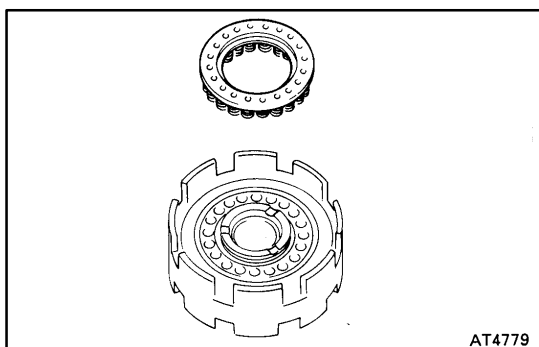

(c) Remove the piston return spring.

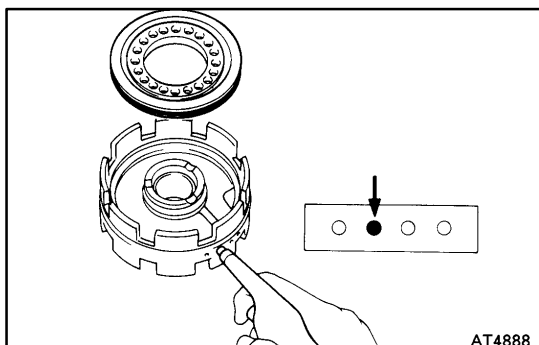

6. REMOVE NO.2 BRAKE PISTON
(a) Hold the No.2 brake piston with hand, apply compressed air to the center support to remove the No.2 brake piston.
(b) Remove the O-ring from the piston.

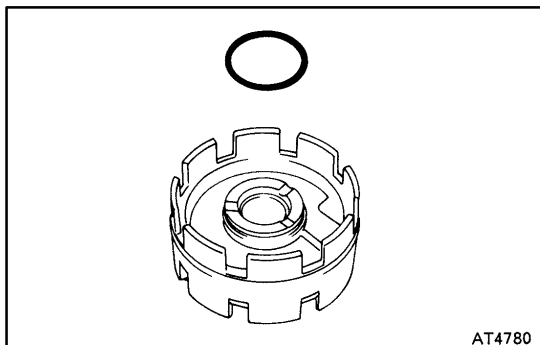

(c) Remove the O-ring from the center support.

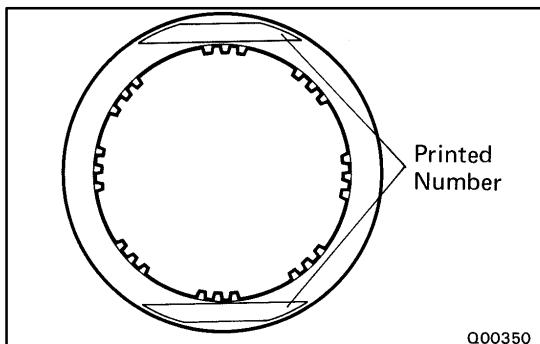

NO.2 BRAKE INSPECTION

AT0B6-03

INSPECT DISC, PLATE AND FLANGE

Check to see if the sliding surface of the disc, plate and flange are worn or burnt. If necessary, replace them.

HINT:

- ★ If the lining of the disc is peeling off or discolored, or even if a parts of the printed numbers are defaced, replace all discs.
- ★ Before assembling new discs, soak them in ATF for at least 15 minutes.

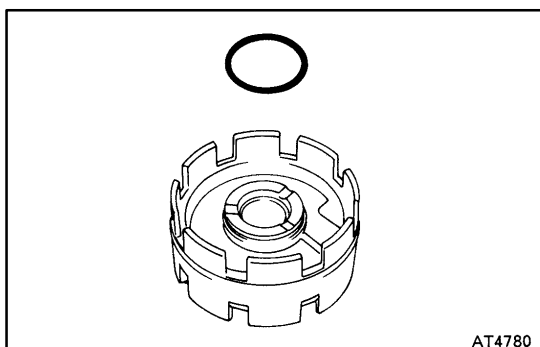

NO.2 BRAKE ASSEMBLY

AT0B7-03

1. INSTALL NO.2 BRAKE PISTON

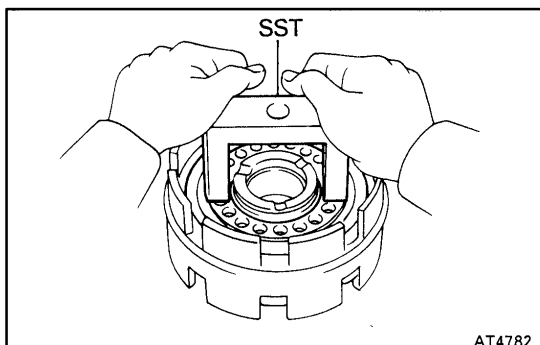

- (a) Coat a new O-ring with ATF and install it on the center support.
- (b) Coat a new O-ring with ATF and install it on the No.2 brake piston.
- (c) Place SST on the No.2 brake piston.
SST 09350-20015 (09369-20040)
- (d) Being careful not to damage the O-rings, press in the No.2 brake piston into the center support with both hands.

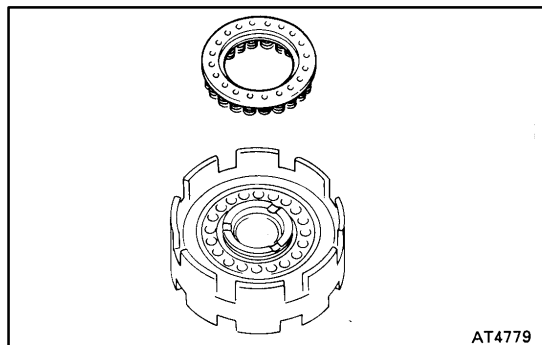

2. INSTALL PISTON RETURN SPRING

(a) Install the piston return spring.

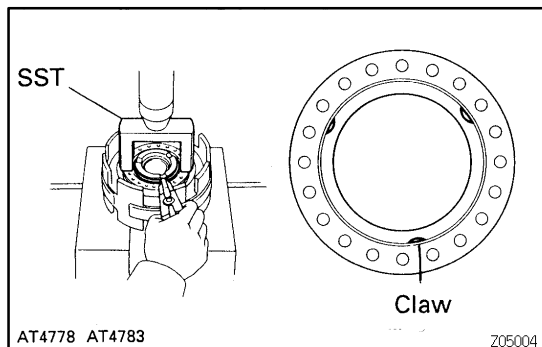

(b) Place SST on the spring seat, and compress the return springs with a shop press.

SST 09350-20015 (09369-20040)

(c) Install the snap ring with a snap ring expander. Be sure the end gap of the snap ring is not aligned with the spring seat claw.

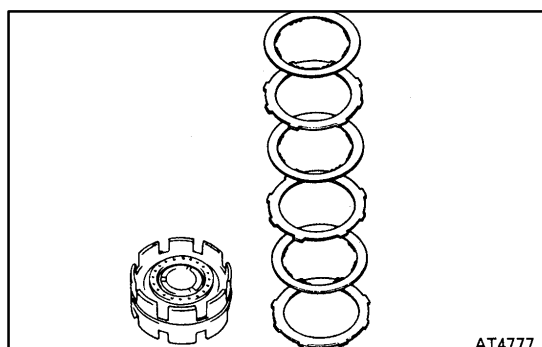

3. INSTALL PLATES AND DISCS

Install the 3 plates and 3 discs.

Install in order: P=Plate D=Disc

P-D-P-D-P-D

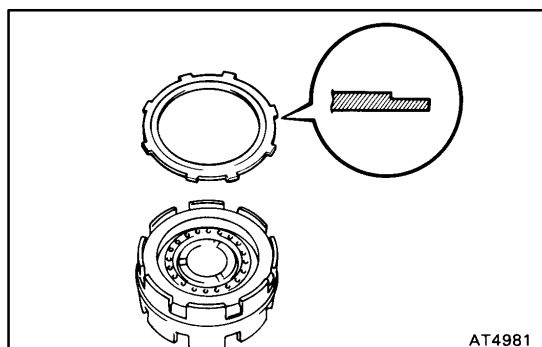

4. INSTALL FLANGE

(a) Install the flange, the flat end facing downward.

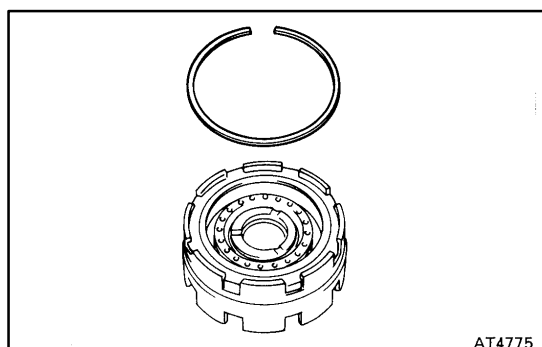

(b) Using a screwdriver, install the snap ring. Be sure the end gap of the snap ring is not aligned with the cutout portion of the center support.

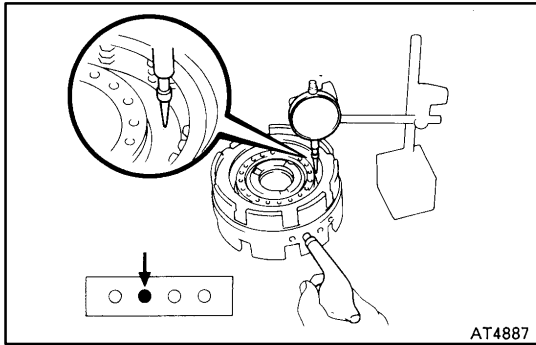

5. CHECK PISTON STROKE OF NO.2 BRAKE

Using a dial indicator, measure the No.2 brake piston stroke while applying and releasing compressed air (392-785 kPa, 4-8 kgf/cm², 57-114 psi).

Piston stroke:

1.01-2.25 mm (0.0398-0.0886 in.)

If the piston stroke is less than the limit, parts may have been assembled incorrectly, check and reassemble again.

6. INSTALL PLANETARY SUN GEAR AND NO.1 ONE-WAY CLUTCH

PLANETARY SUN GEAR COMPONENTS

AT088-03

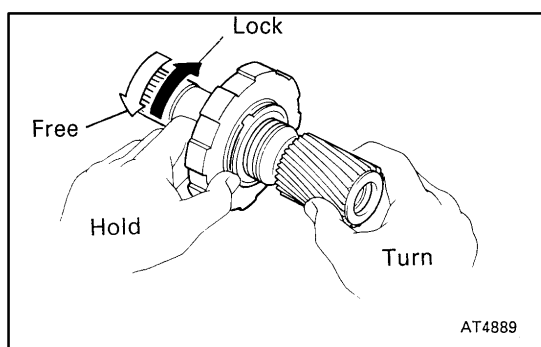
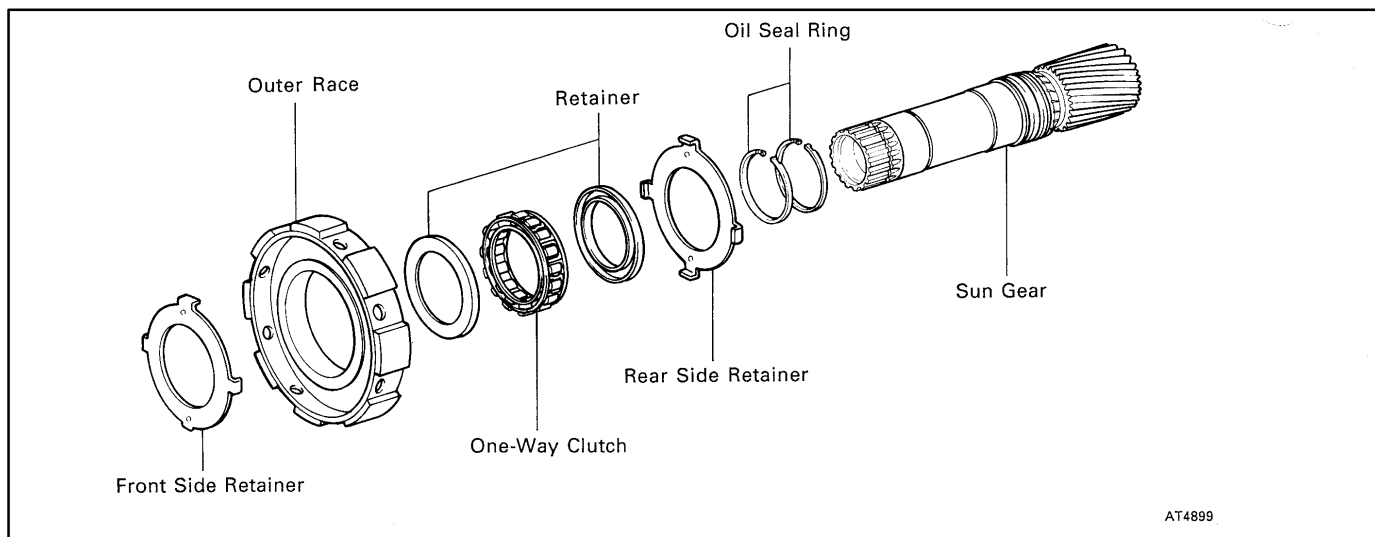

PLANETARY SUN GEAR AND NO.1 ONE-WAY CLUTCH DISASSEMBLY

AT089-03

1. REMOVE PLANETARY SUN GEAR AND NO.1 ONE-WAY CLUTCH

2. CHECK OPERATION OF NO.1 ONE-WAY CLUTCH
Hold No.1 one-way clutch and turn the planetary sun gear. The planetary sun gear turns freely counterclockwise and locks clockwise.

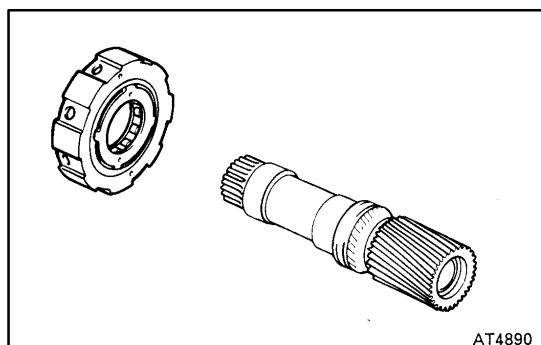

3. REMOVE NO.1 ONE-WAY CLUTCH FROM PLANETARY SUN GEAR

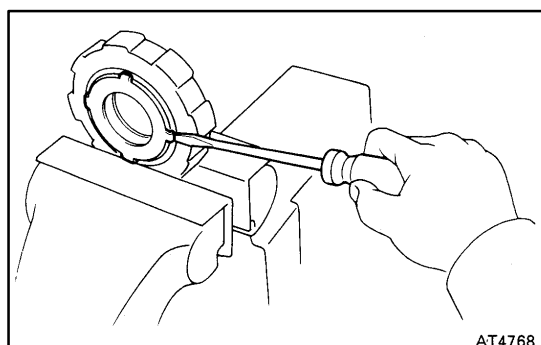

4. DISASSEMBLE NO.1 ONE-WAY CLUTCH

- (a) Using a screwdriver, loosen the staked parts of the rear side retainer.
- (b) Remove the retainer.

AT-64

AUTOMATIC TRANSMISSION - PLANETARY SUN GEAR

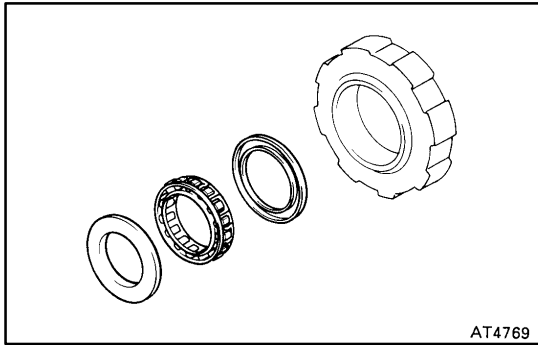

(c) Remove the one-way clutch and 2 retainers from the outer race.

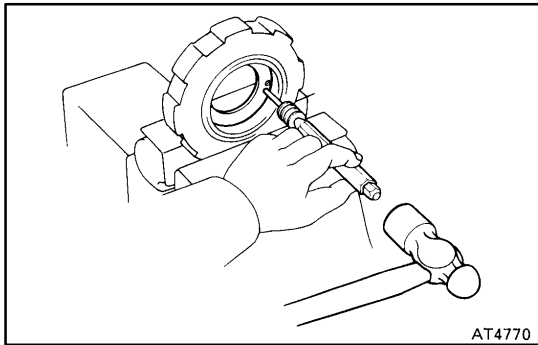

(d) Using a pin punch and hammer, remove the front side retainer.

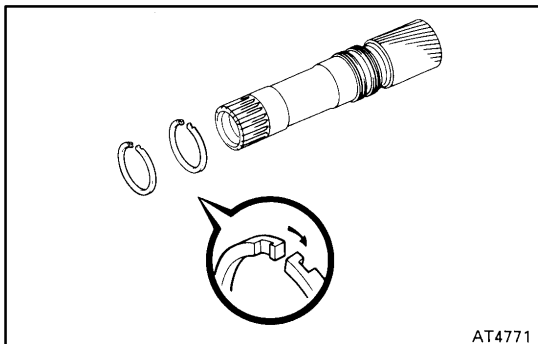

5. REMOVE OIL SEAL RINGS

Remove the 2 oil seal rings.

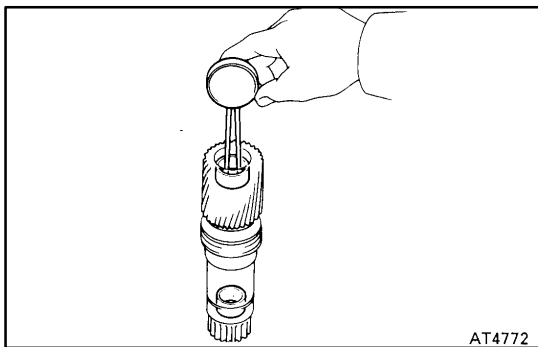

PLANETARY SUN GEAR INSPECTION

AT0BA-03

CHECK PLANETARY SUN GEAR BUSHINGS

Using a dial indicator, measure the inside diameter of the planetary sun gear bushings.

Maximum inside diameter:

21.58 mm (0.8496 in.)

If the inside diameter is greater than the maximum, replace the planetary sun gear.

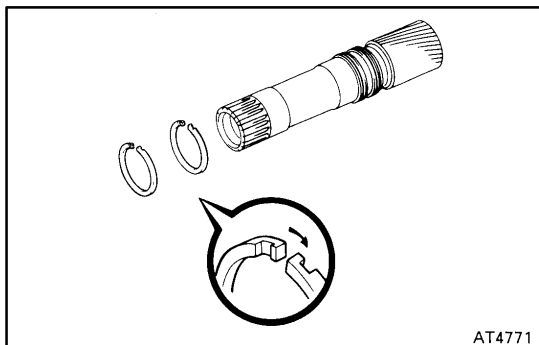

AT4771

PLANETARY SUN GEAR AND NO.1 ONE-WAY CLUTCH ASSEMBLY

1. INSTALL OIL SEAL RINGS

- (a) Coat the 2 oil seal rings with ATF.
- (b) Install the oil seal rings to the planetary sun gear, then snug them down by squeezing their ends together.

NOTICE: Do not spread the ring ends too much.

HINT: After installing the oil seal rings, check that they rotate smoothly.

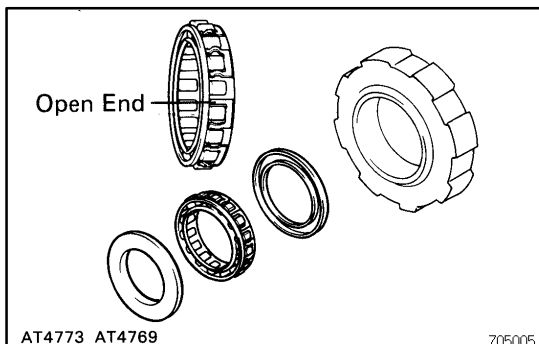

AT4773 AT4769

Z05005

2. ASSEMBLE NO.1 ONE-WAY CLUTCH

- (a) Install the one-way clutch into the outer race, the open end of the retainers facing rearward.
- (b) Install the 2 retainers into both sides.

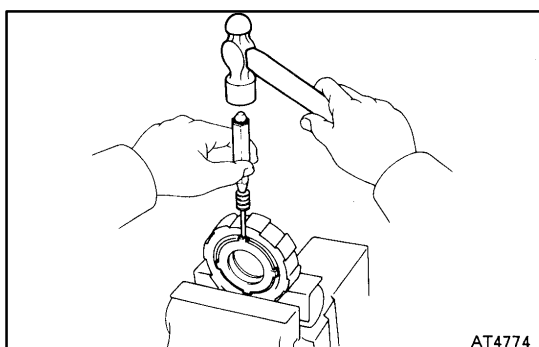

AT4774

- (c) Install 2 new retainers to the outer race.
- (d) Using a pin punch and hammer, stake the claws.

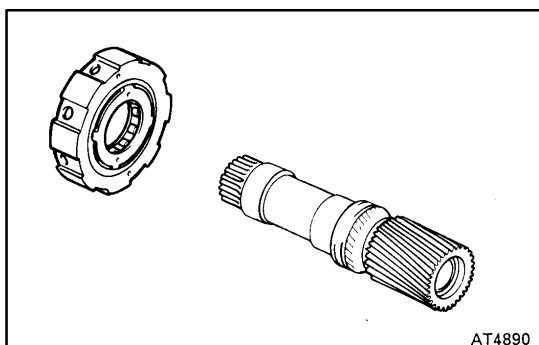

AT4890

3. INSTALL NO.1 ONE-WAY CLUTCH TO PLANETARY SUN GEAR

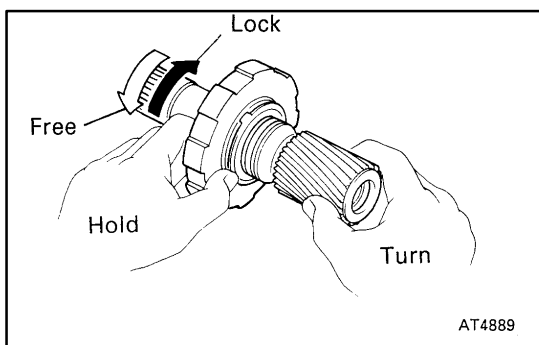

AT4889

4. CHECK OPERATION OF NO.1 ONE-WAY CLUTCH

Hold No.1 one-way clutch and turn the planetary sun gear. The planetary sun gear turns freely counterclockwise and locks clockwise.

5. INSTALL PLANETARY SUN GEAR AND NO.1 ONE-WAY CLUTCH

FRONT PLANETARY GEAR COMPONENTS

AT0BC-03

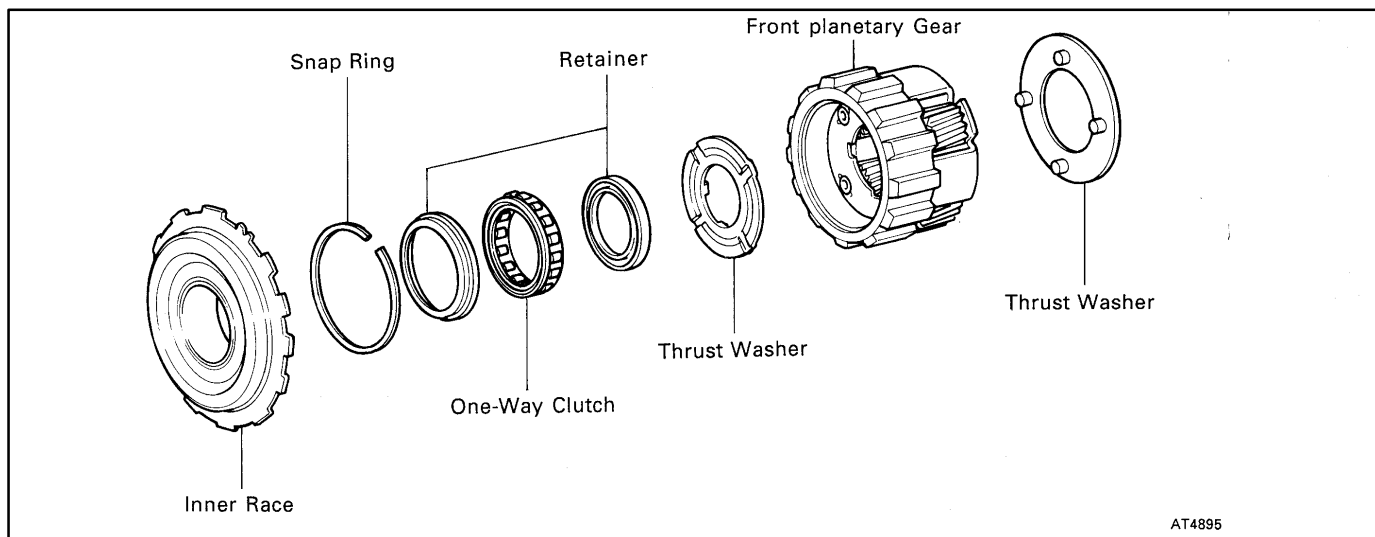

AT4895

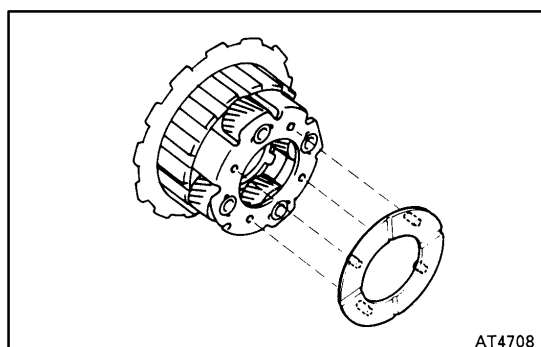

AT4708

FRONT PLANETARY GEAR AND NO.2 ONE-WAY CLUTCH DISASSEMBLY

AT0BD-03

1. REMOVE THRUST WASHER FROM FRONT PLANETARY CARRIER

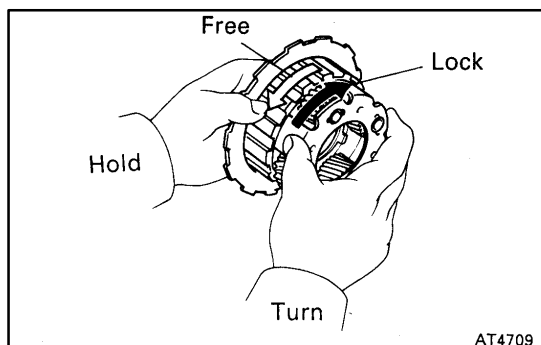

AT4709

2. CHECK OPERATION OF NO.2 ONE-WAY CLUTCH
Hold the one-way clutch inner race and turn the planetary gear. The planetary gear turns freely counterclockwise and locks clockwise.

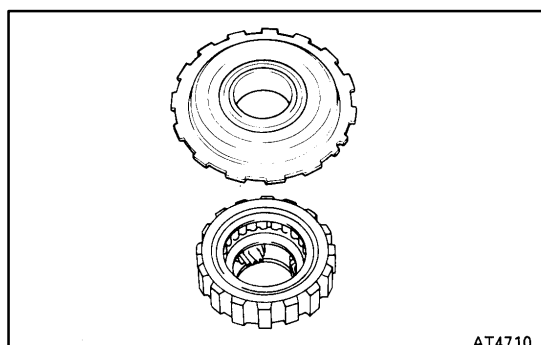

AT4710

3. REMOVE ONE-WAY CLUTCH INNER RACE

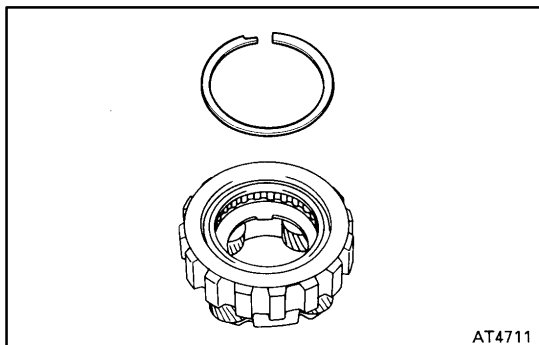

4. REMOVE NO.2 ONE-WAY CLUTCH

(a) Using a screwdriver, remove the snap ring.

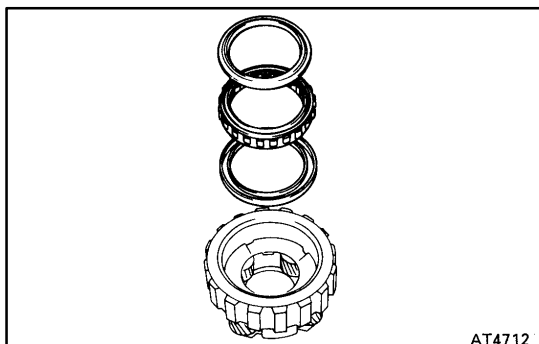

(b) Remove the one-way clutch and 2 retainers from the planetary gear.

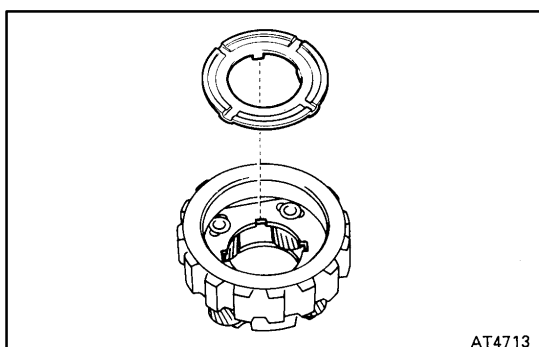

5. REMOVE THRUST WASHER

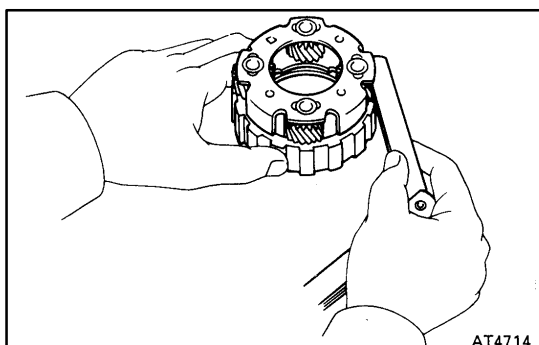

FRONT PLANETARY GEAR INSPECTION

AT0BE-03

MEASURE PLANETARY PINION GEAR THRUST CLEARANCE

Using a feeler gauge, measure the planetary pinion gear thrust clearance.

Standard clearance:

0.20-0.50 mm (0.0079-0.0197 in.)

If the clearance is non-standard, inspect the planetary gear thrust washer.

If necessary, replace the planetary gear assembly.

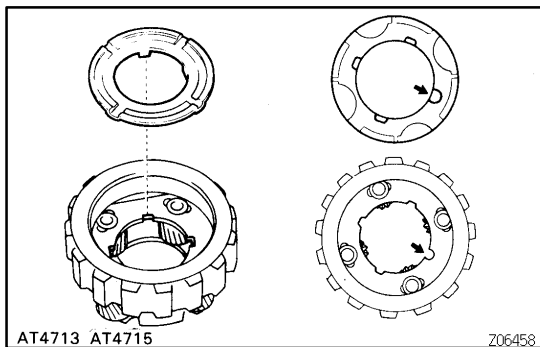

FRONT PLANETARY GEAR AND NO.2 ONE-WAY CLUTCH ASSEMBLY

1. INSTALL THRUST WASHER

- (a) Coat the thrust washer with petroleum jelly.
- (b) Install the thrust washer into the front planetary gear.
HINT: Make sure that the lug shapes match the cutout portions on the front planetary gear.

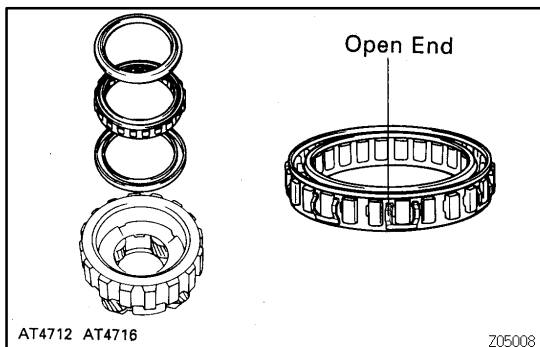

2. INSTALL NO.2 ONE-WAY CLUTCH

- (a) Install the one-way clutch and two retainers into the front planetary gear.
HINT: Make sure that the open end of the retainers on the one-way clutch are faced upward.

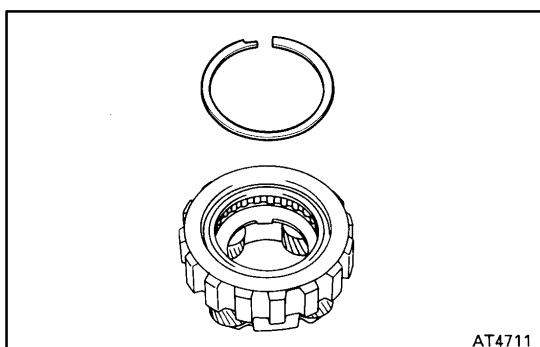

- (b) Using a screwdriver, install the snap ring.

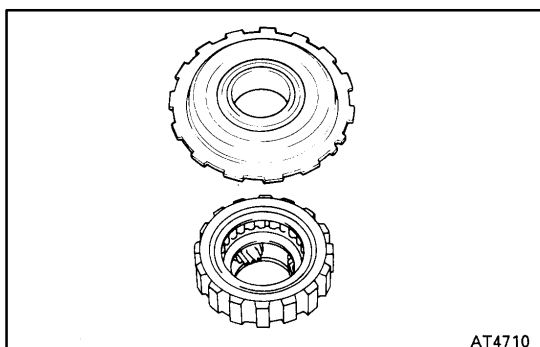

3. INSTALL ONE-WAY CLUTCH INNER RACE

Install the inner race while turning it counterclockwise.

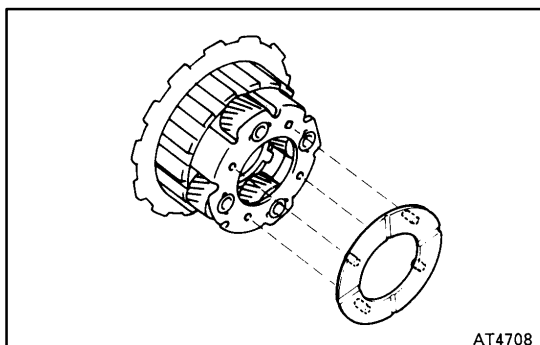

4. INSTALL THRUST WASHER

- (a) Coat the thrust washer with petroleum jelly.
- (b) Install thrust washer onto the front planetary gear.
HINT: Make sure that the lug shapes match the holes on the front planetary gear.

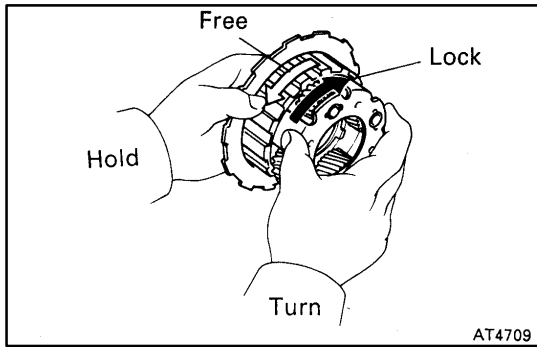

5. **CHECK OPERATION OF NO.2 ONE-WAY CLUTCH**
 Hold the one-way clutch inner race and turn the planetary gear. The planetary gear turns freely counterclockwise and locks clockwise.

REAR PLANETARY GEAR COMPONENTS

AT0BG-03

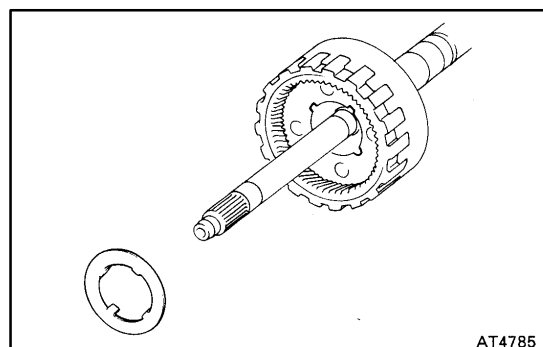
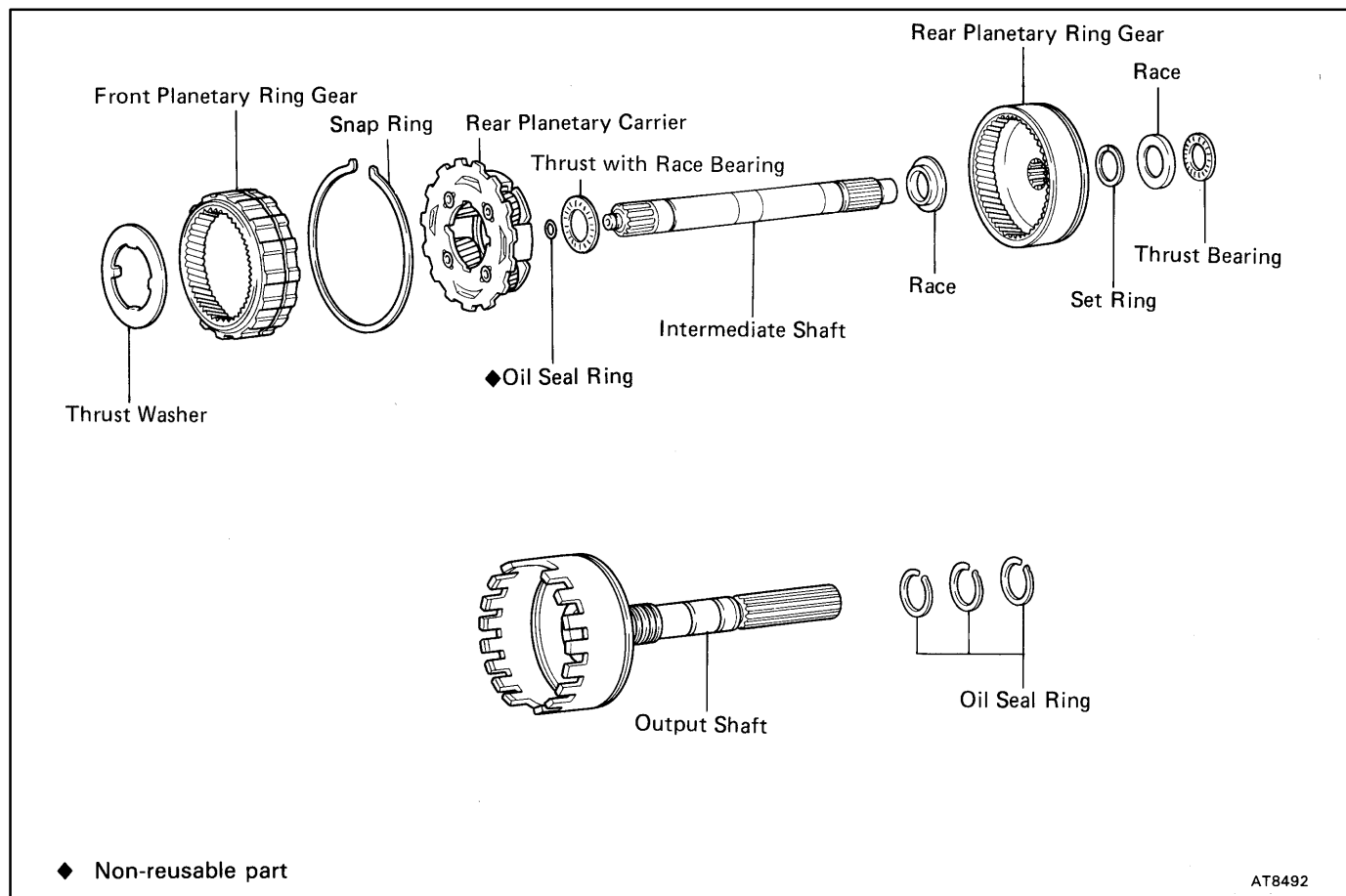

REAR PLANETARY GEAR AND OUTPUT SHAFT DISASSEMBLY

AT0BH-03

1. REMOVE THRUST WASHER FROM FRONT PLANETARY RING GEAR

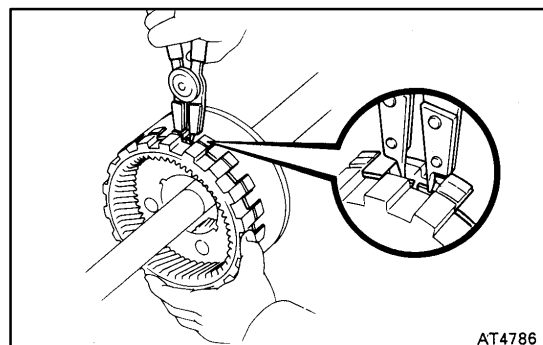

2. REMOVE FRONT PLANETARY RING GEAR
 - (a) Using a snap ring expander, pull out the ring gear while compressing the snap ring.

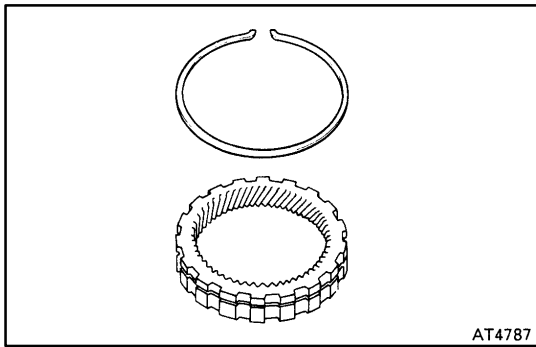

- (b) Using a screwdriver, remove the snap ring from the ring gear.

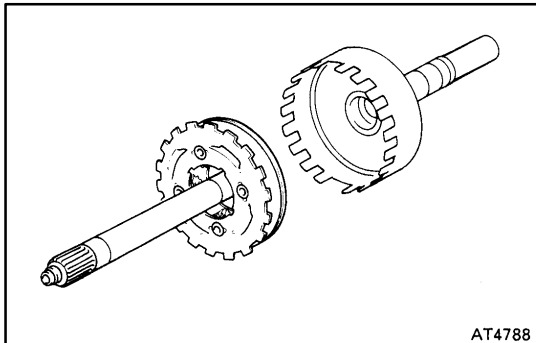

3. REMOVE REAR PLANETARY GEAR ASSEMBLY FROM OUTPUT SHAFT

- (a) Pull out the rear planetary gear assembly.

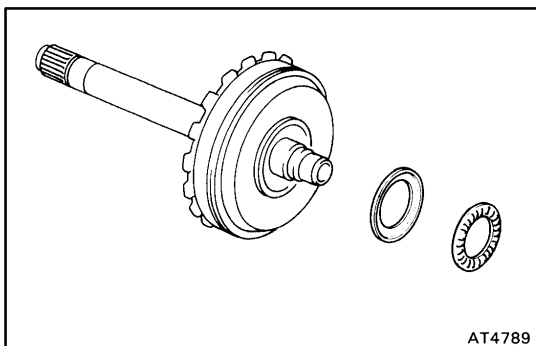

- (b) Remove the bearing and race.

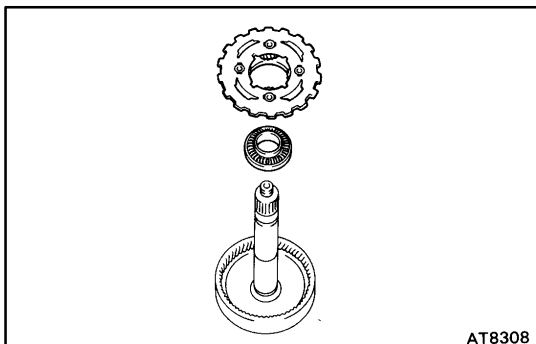

4. REMOVE REAR PLANETARY CARRIER AND ASSEMBLED THRUST WITH RACE BEARING AND RACE FROM PLANETARY RING GEAR

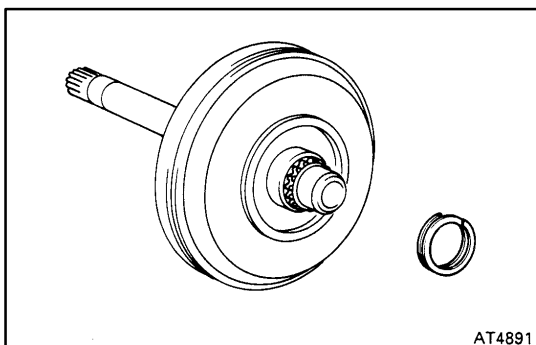

5. REMOVE PLANETARY RING GEAR

- (a) Using a screwdriver, remove the set ring.

AT-72

AUTOMATIC TRANSMISSION - REAR PLANETARY GEAR

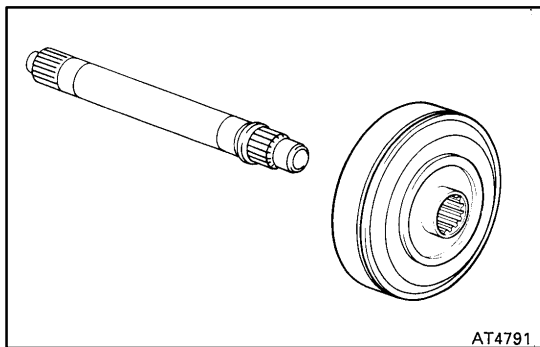

(b) Remove the planetary ring gear.

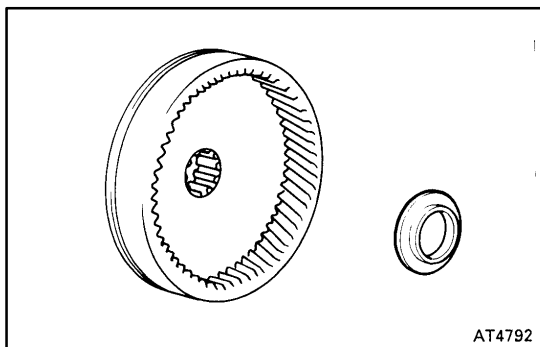

(c) Remove the race from the ring gear.

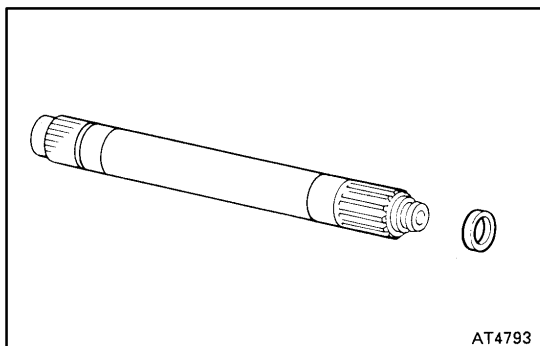

6. REMOVE OIL SEAL RING FROM INTERMEDIATE SHAFT

Using a screwdriver, remove the oil seal ring.

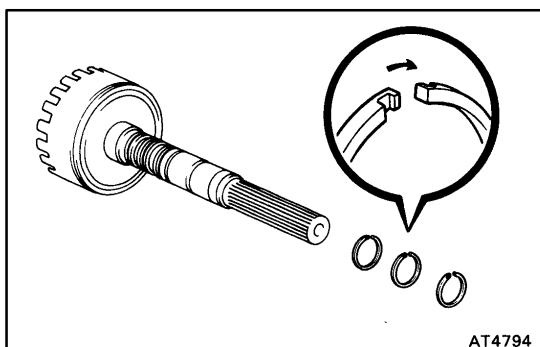

7. REMOVE OIL SEAL RINGS FROM OUTPUT SHAFT

Remove the 3 oil seal rings.

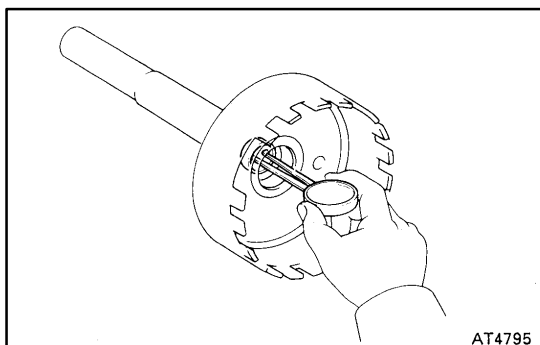

REAR PLANETARY GEAR AND OUTPUT SHAFT INSPECTION

ATOBJ-03

1. CHECK OUTPUT SHAFT BUSHING

Using a dial indicator, measure the inside diameter of the output shaft bushing.

Maximum inside diameter:

18.08 mm (0.7118 in.)

If the inside diameter is greater than the maximum, replace the output shaft.

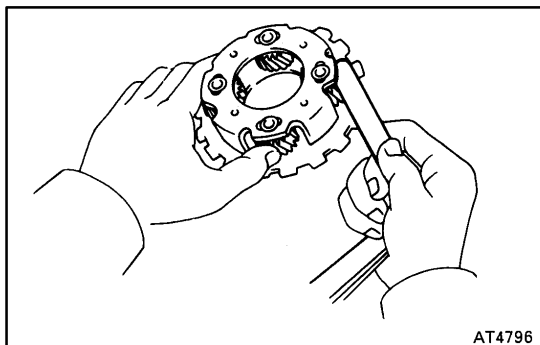

2. MEASURE PLANETARY PINION GEAR THRUST CLEARANCE

Using a feeler gauge, measure the planetary pinion gear thrust clearance.

Standard clearance:

0.20-0.50 mm (0.0079-0.0197 in.)

If the clearance is non-standard, inspect the planetary gear thrust washer.

If necessary, replace the planetary gear assembly.

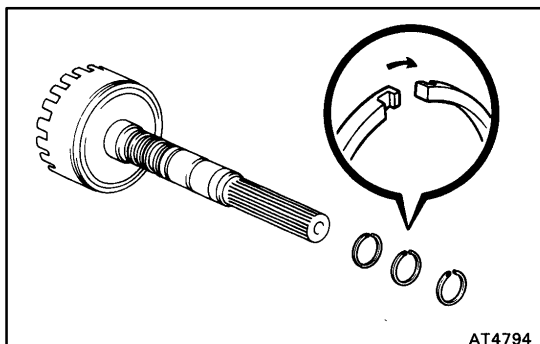

REAR PLANETARY GEAR AND OUTPUT SHAFT ASSEMBLY

AT0BK-03

1. INSTALL OIL SEAL RINGS

- (a) Coat the 3 oil seal rings with ATF.
- (b) Install the oil seal rings to the output shaft, then snug them down by squeezing their ends together.

NOTICE: Do not spread the ring ends too much.

HINT: After installing the oil seal rings, check that they rotate smoothly.

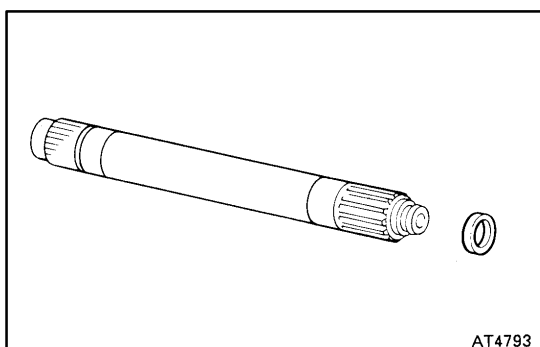

2. INSTALL NEW OIL SEAL RING

Coat a new oil seal ring with ATF and install it to the intermediate shaft.

NOTICE: Do not spread the ring too much.

HINT: After installing the oil seal ring, check that it rotates smoothly.

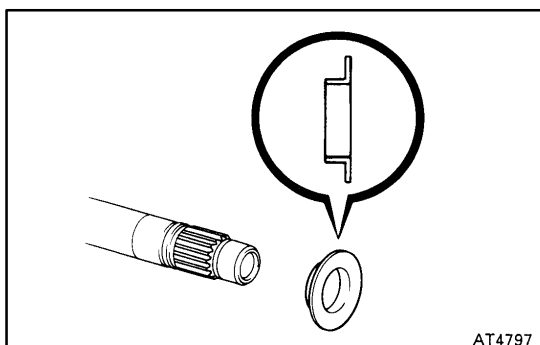

3. INSTALL PLANETARY RING GEAR

- (a) Coat the race with petroleum jelly and install it onto the intermediate shaft.

Race diameter

mm (in.)

	Inside	Outside
Race	21.4 (0.843)	41.4 (1.630)

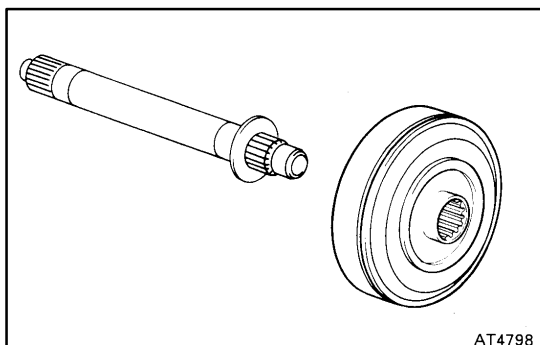

- (b) Install the ring gear to the intermediate shaft.

AT-74

AUTOMATIC TRANSMISSION - REAR PLANETARY GEAR

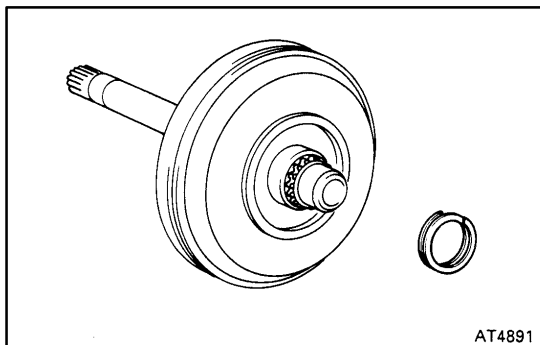

(c) Install the set ring.

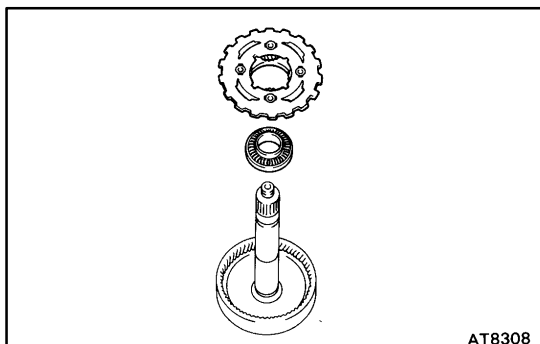

4. **INSTALL ASSEMBLED THRUST WITH RACE BEARING AND REAR PLANETARY CARRIER TO PLANETARY RING GEAR**

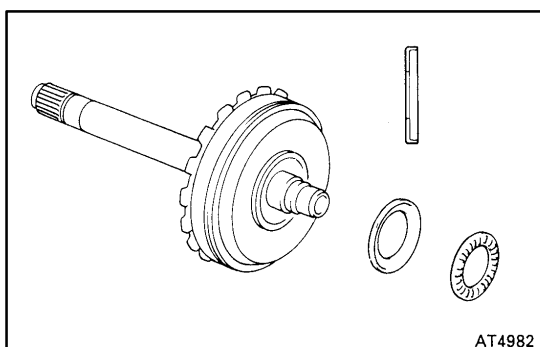

5. **INSTALL REAR PLANETARY GEAR ASSEMBLY TO OUTPUT SHAFT**

(a) Coat the bearing and race with petroleum jelly and install them onto the ring gear.

Bearing and race diameter

mm (in.)

	Inside	Outside
Race	30.1 (1.185)	48.5 (1.909)
Bearing	28.4 (1.118)	46.3 (1.823)

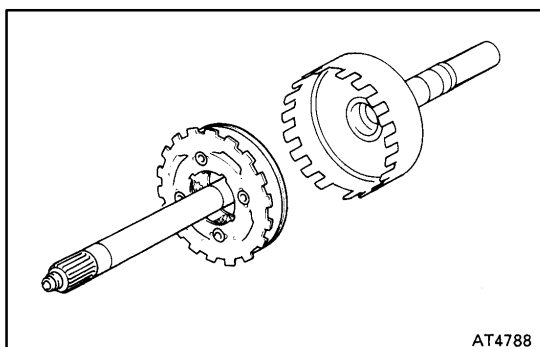

(b) Install the rear planetary gear assembly to the output shaft.

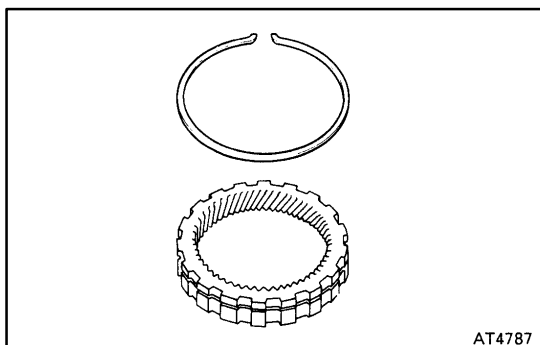

6. **INSTALL FRONT PLANETARY RING GEAR**

(a) Install the snap ring.

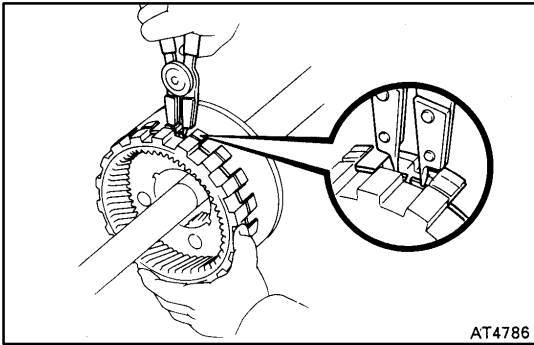

- (b) Align the snap ring end with the wide cutout portion of the output shaft.
- (c) Using a snap ring expander, install the ring gear while compressing the snap ring.
- (d) Check that the snap ring is installed into the groove of the output shaft.

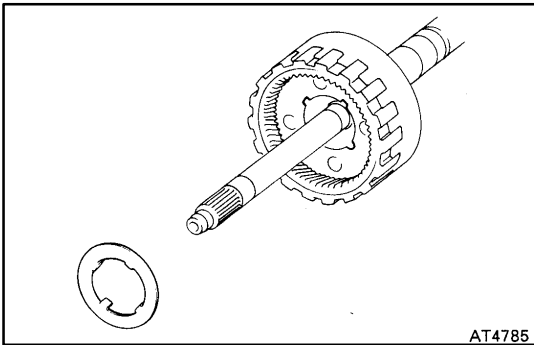

7. INSTALL THRUST WASHER

- (a) Coat the thrust washer with petroleum jelly.
- (b) Install the thrust washer onto the rear planetary carrier.
HINT: Make sure that the lug shapes match the cutout portions on the rear planetary carrier.

NO.3 BRAKE COMPONENTS

AT0BL-03

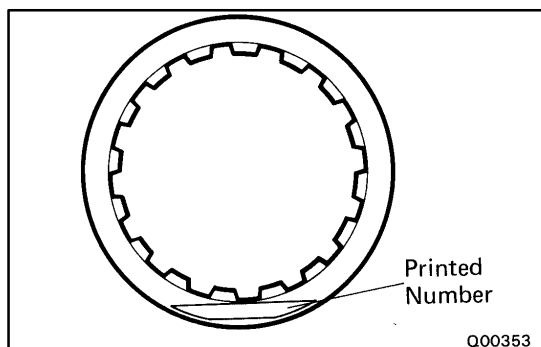
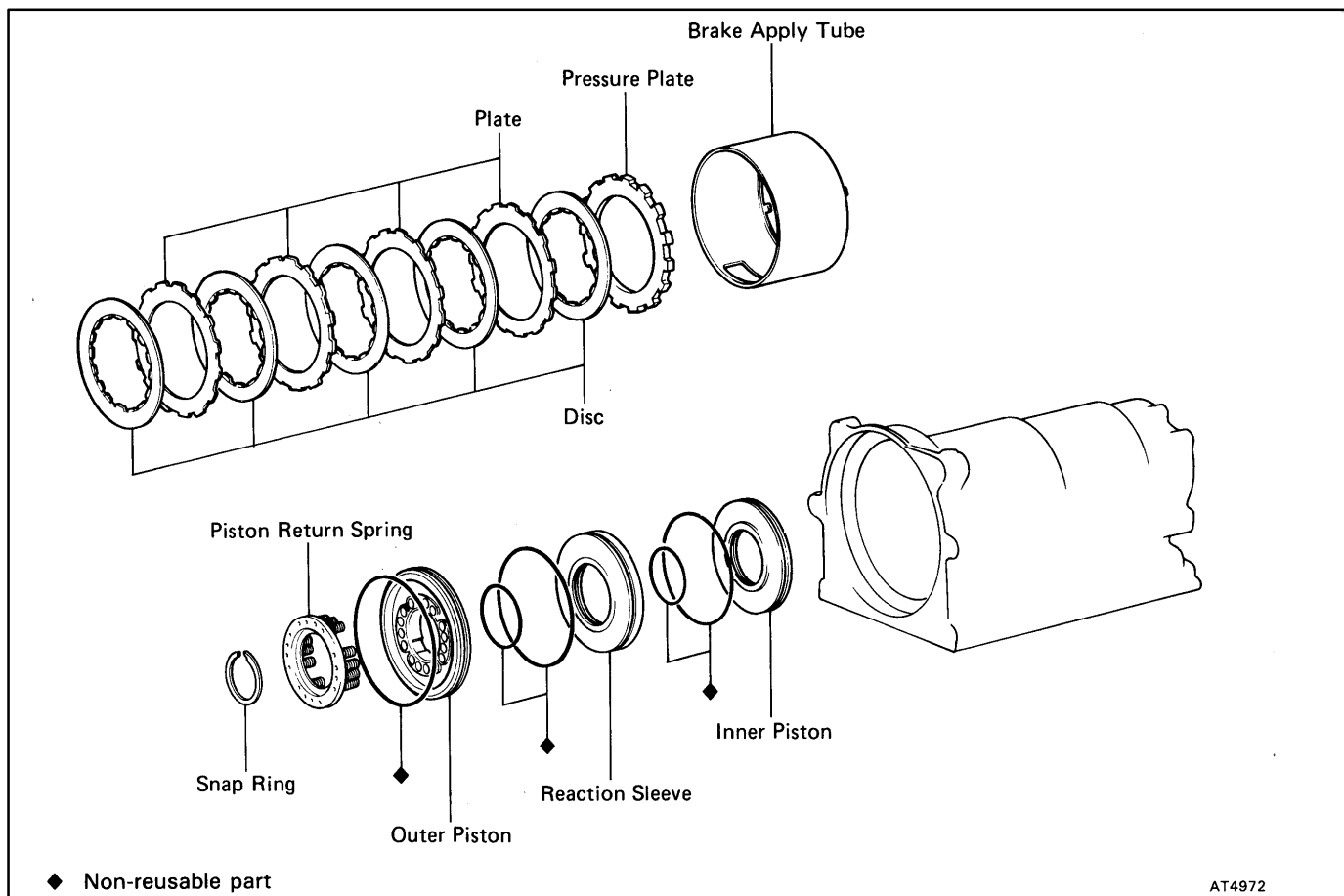

NO.3 BRAKE INSPECTION

AT0BM-03

INSPECT DISC AND PLATE

Check to see if the sliding surface of the disc and plate are worn or burnt. If necessary, replace them.

HINT:

- ★ If the lining of the disc is peeling off or discolored, or even if a parts of the printed numbers are defaced, replace all discs.
- ★ Before assembling new discs, soak them in ATF for at least 15 minutes.

VALVE BODY COMPONENTS

AT0BN-03

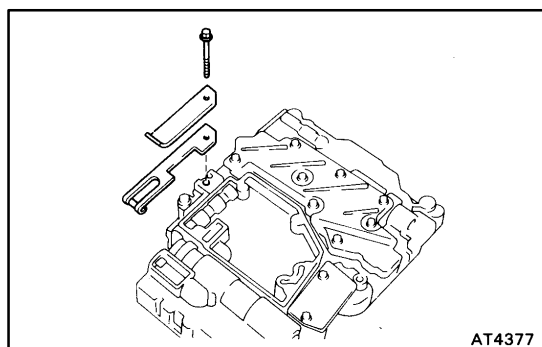
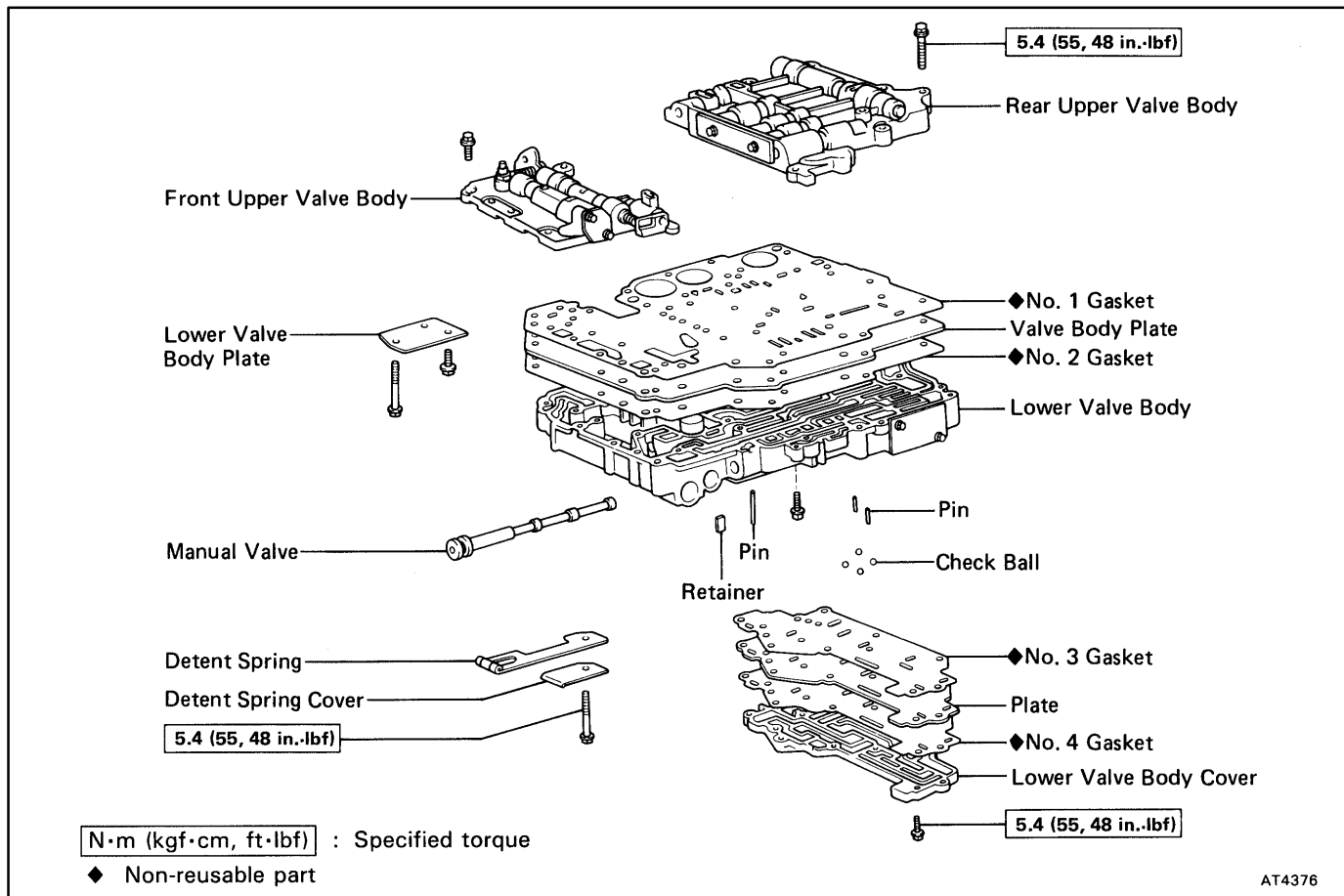

VALVE BODY DISASSEMBLY

1. REMOVE DETENT SPRING

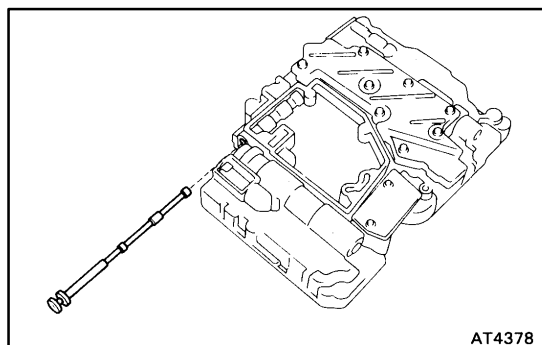

2. REMOVE MANUAL VALVE

AT0BP-02

AT-78

AUTOMATIC TRANSMISSION - VALVE BODY

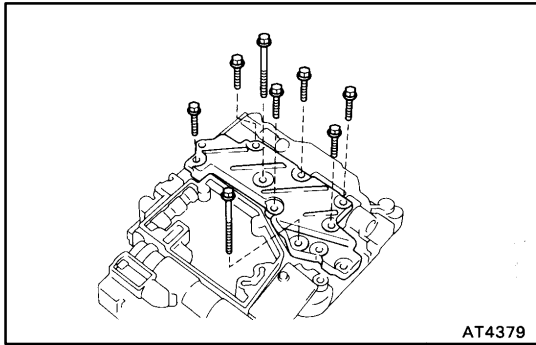

3. REMOVE LOWER VALVE BODY COVER

(a) Remove the 8 bolts and lower valve body cover.

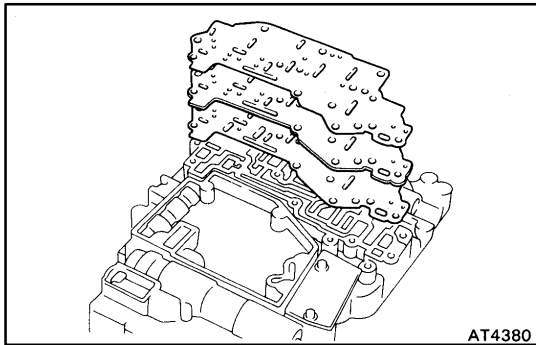

(b) Remove the 2 gaskets and plate.

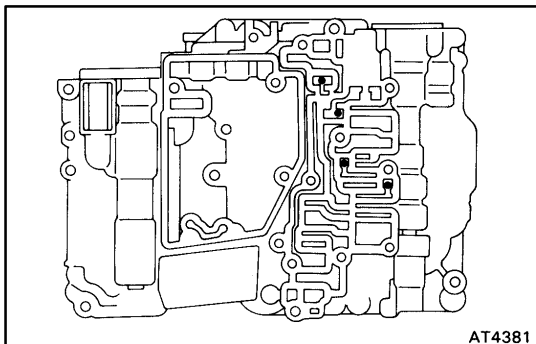

(c) Remove the 4 check balls.

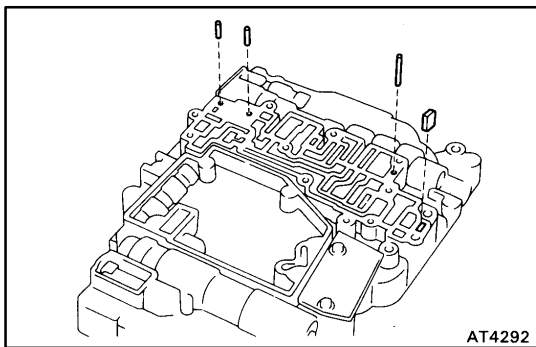

(d) Remove the retainer and 3 pins.

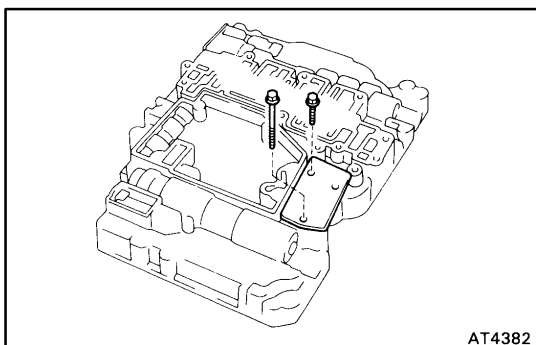

4. REMOVE LOWER VALVE BODY PLATE

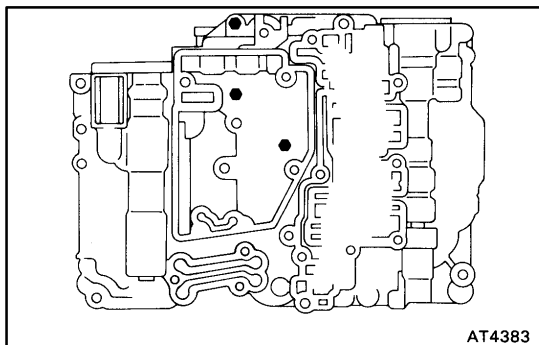

- 5. REMOVE BOLTS FROM LOWER VALVE BODY**
Remove the 3 bolts.

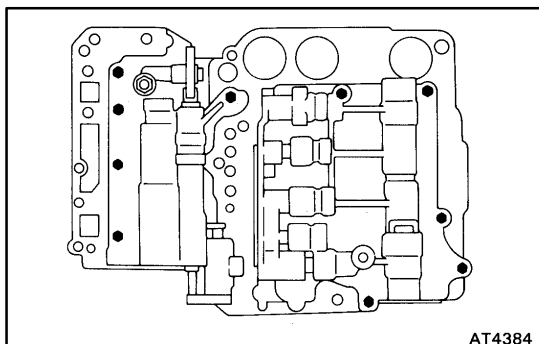

- 6. REMOVE BOLTS FROM FRONT AND REAR UPPER VALVE BODIES**
- (a) Turn over the valve body.
 - (b) Remove the 5 bolts from the front upper valve body, and remove the 5 bolts from the rear upper valve body.

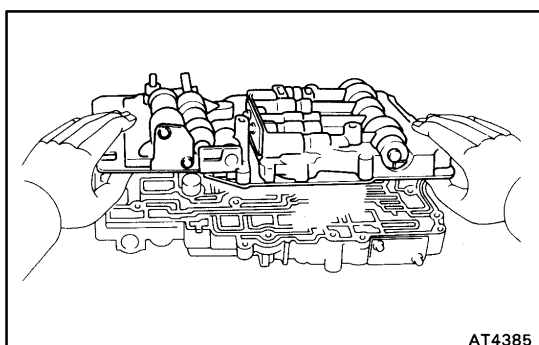

- 7. LIFT OFF FRONT AND REAR UPPER VALVE BODIES AND PLATE AS A SINGLE UNIT**
- (a) Hold the valve body plate to the upper valve bodies and lift off the upper valve bodies.
HINT: Be careful that the check balls and retainers do not fall out.

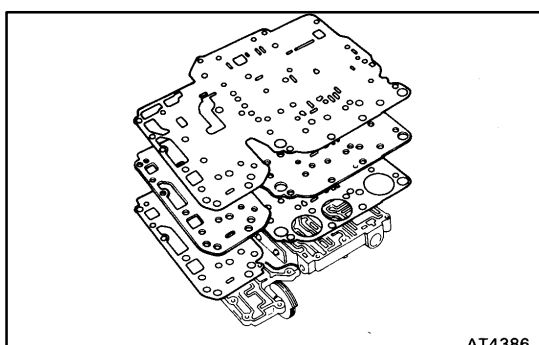

- (b) Remove the 2 gaskets and plate.

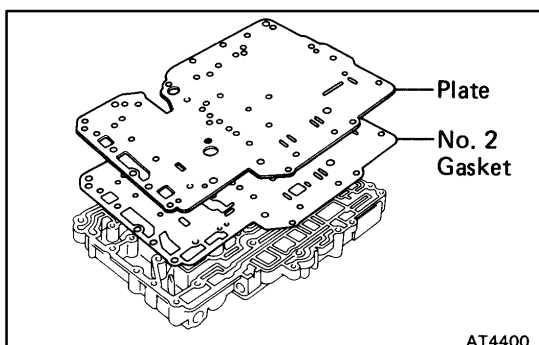

VALVE BODY ASSEMBLY

AT0BQ-02

- 1. POSITION NEW NO.2 GASKET AND PLATE ON LOWER VALVE BODY**
- (a) Place a new No.2 gasket and plate on the lower valve body.
HINT: Since No.1 gasket and No.2 gasket look similar, use the illustrations below to differentiate between them.

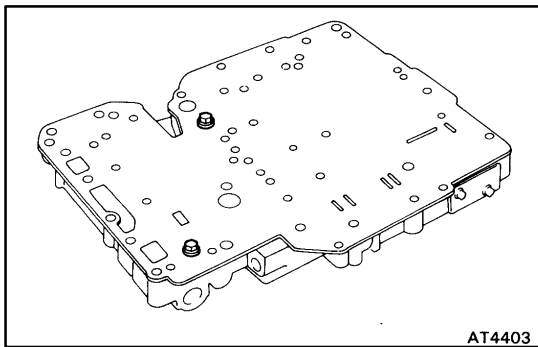
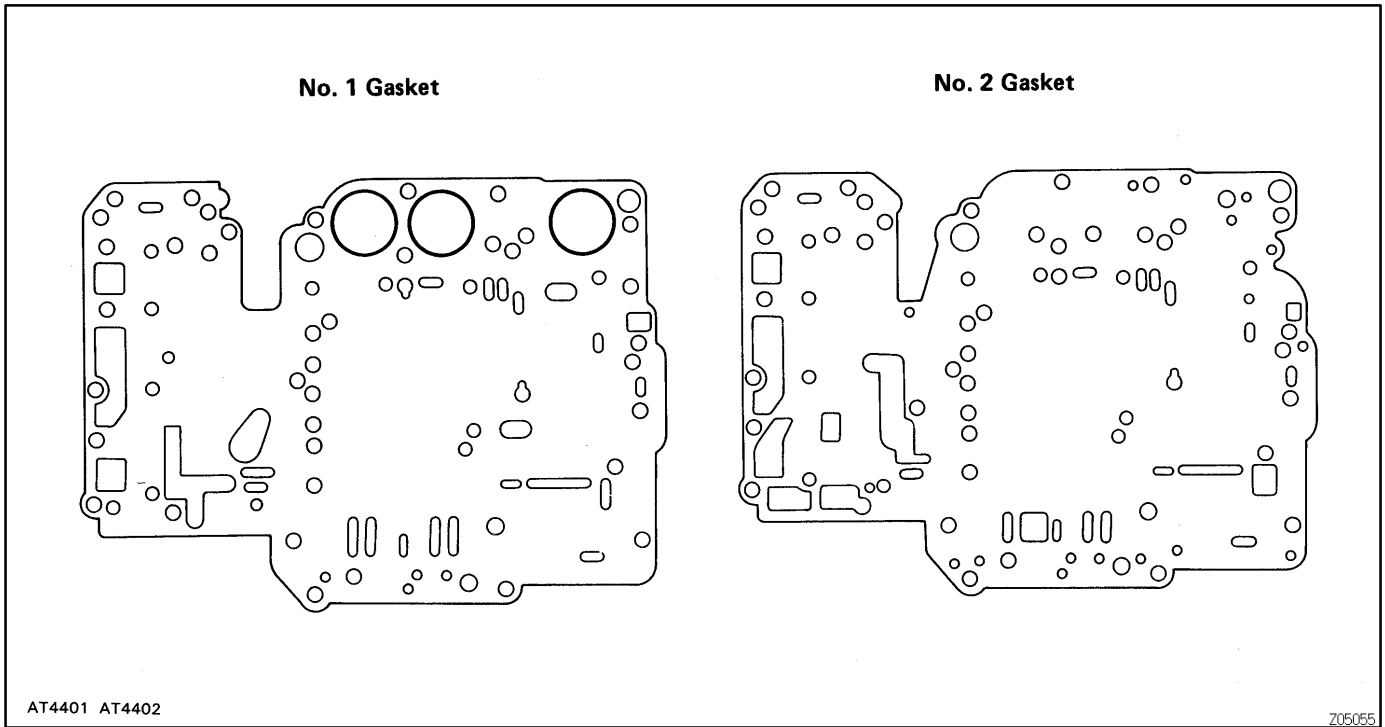

- (b) Temporarily secure the plate with the 2 bolts.
HINT: Use the two bolts for the oil strainer.

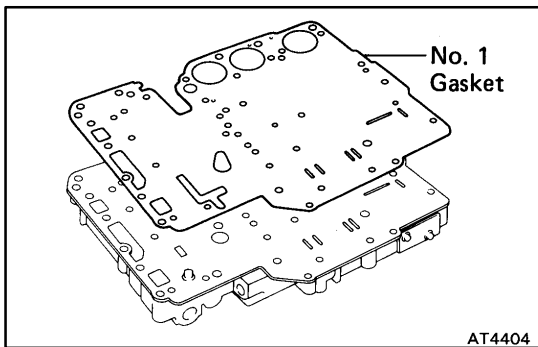

2. POSITION NEW NO.1 GASKET ON PLATE

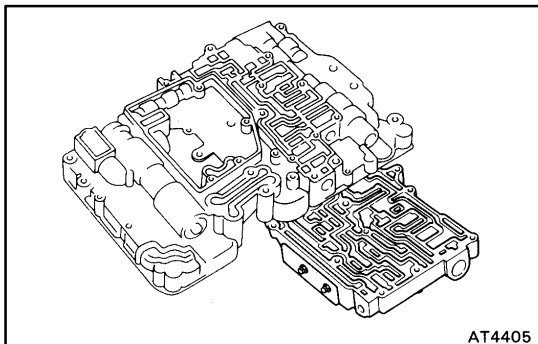

- 3. PLACE LOWER VALVE BODY WITH PLATE AND GASKETS ON REAR UPPER VALVE BODY**
Hold the lower valve body, plate and gaskets securely so they do not separate.
Align each bolt hole in the valve bodies with the gaskets and plate.

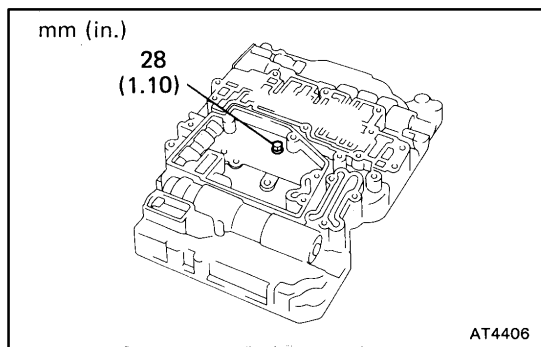

4. INSTALL AND FINGER TIGHTEN BOLTS IN LOWER VALVE BODY TO SECURE REAR UPPER VALVE BODY

- (a) Install and finger tighten the bolt.
HINT: Bolt length (mm, in.) is indicated in the illustration.

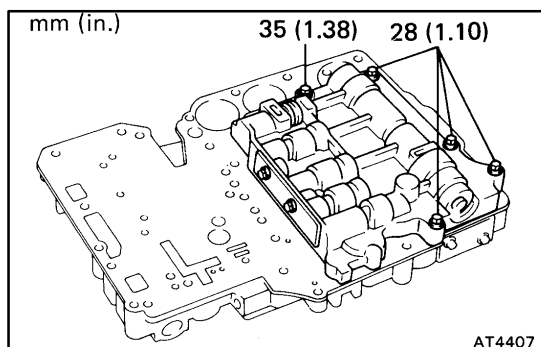

- (b) Hold the rear upper valve body and lower valve body, turn over the assembly.
(c) Install and finger tighten the 5 bolts.
HINT: Each bolt length (mm, in.) is indicated in the illustration.

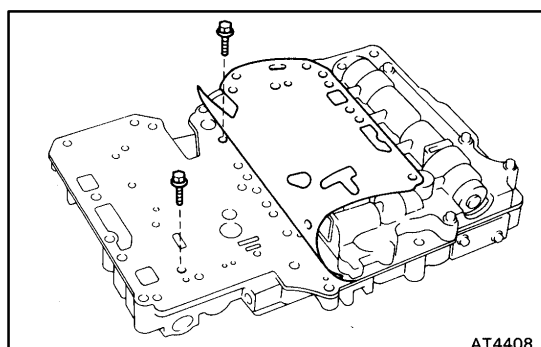

- (d) Remove the temporarily installed bolts.

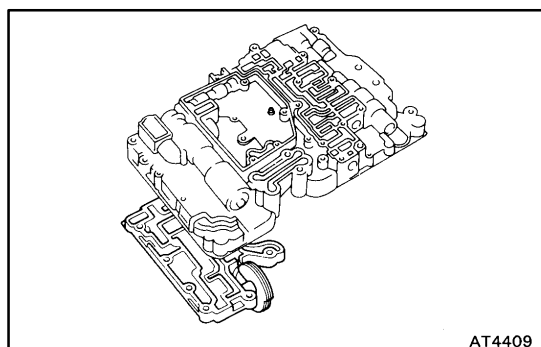

5. PLACE LOWER VALVE BODY AND REAR UPPER VALVE BODY ON FRONT UPPER VALVE BODY

Align each bolt hole in the valve bodies with the gaskets and plate.

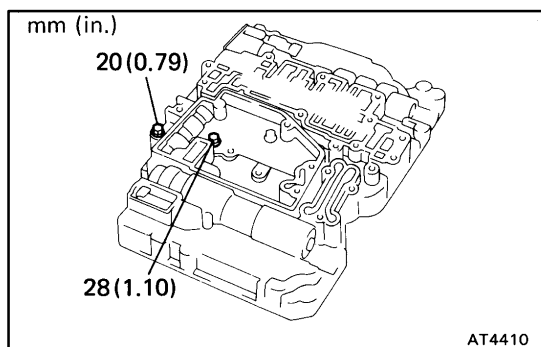

6. INSTALL AND FINGER TIGHTEN BOLTS IN LOWER VALVE BODY TO SECURE FRONT UPPER VALVE BODY

- (a) Install and finger tighten the 2 bolts.
HINT: Each bolt length (mm, in.) is indicated in the illustration.

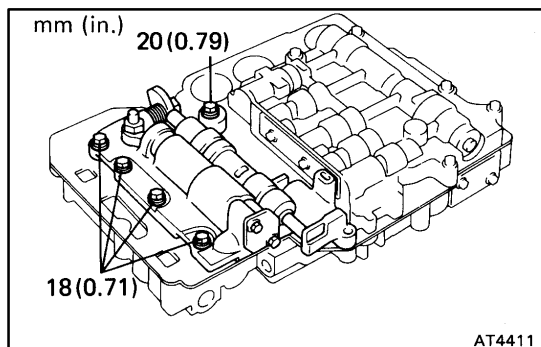

- (b) Hold the front upper valve body and lower valve body, turn over the assembly.
- (c) Install and finger tighten the 5 bolts.
HINT: Each bolt length (mm, in.) is indicated in the illustration.

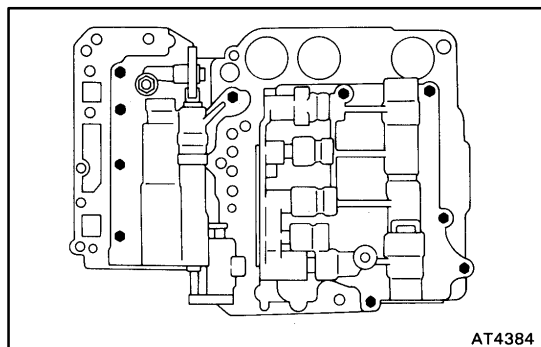

7. TIGHTEN BOLTS OF UPPER AND LOWER VALVE BODIES

- (a) Tighten the 10 bolts in the upper valve bodies.
Torque: 5.4 N·m (55 kgf·cm, 48 in.-lbf)

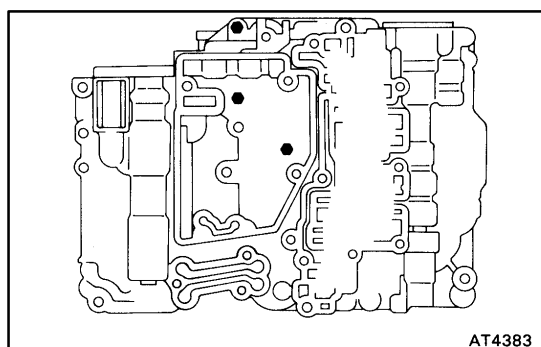

- (b) Tighten the 3 bolts in the lower valve body.
Torque: 5.4 N·m (55 kgf·cm, 48 in.-lbf)

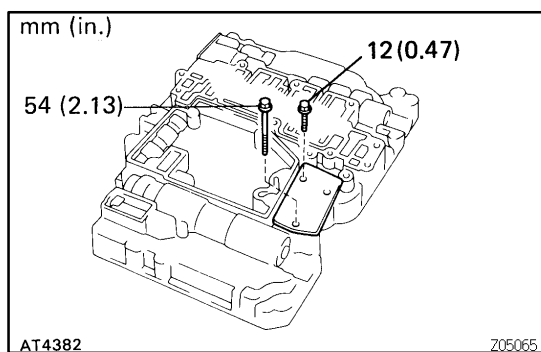

8. INSTALL LOWER VALVE BODY PLATE

HINT: Each bolt length (mm, in.) is indicated in the illustration.

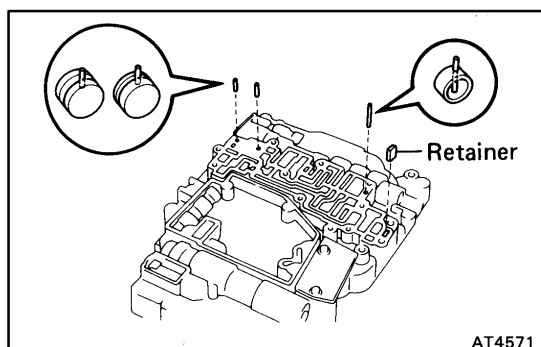

9. INSTALL LOWER VALVE BODY COVER

- (a) Install the retainer and 3 pins.

Retainer:

Height 8.5 mm (0.335 in.)

Width 5.0 mm (0.197 in.)

Thickness 3.2 mm (0.126 in.)

AUTOMATIC TRANSMISSION - VALVE BODY

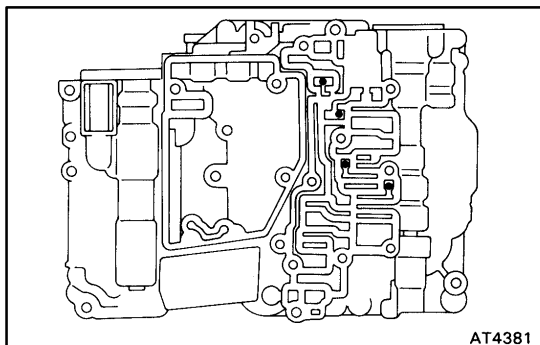

AT4381

(b) Install the 4 check balls.

Check ball:

Rubber ball diameter

5.5 mm (0.217 in.)

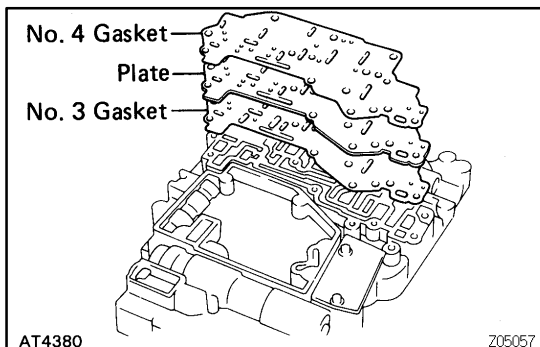

AT4380

Z05057

(c) Place a new No.3 and No.4 gaskets and plate on the lower valve body.

HINT: Since No.3 gasket and No.4 gasket look similar, use the illustrations below to differentiate between them.

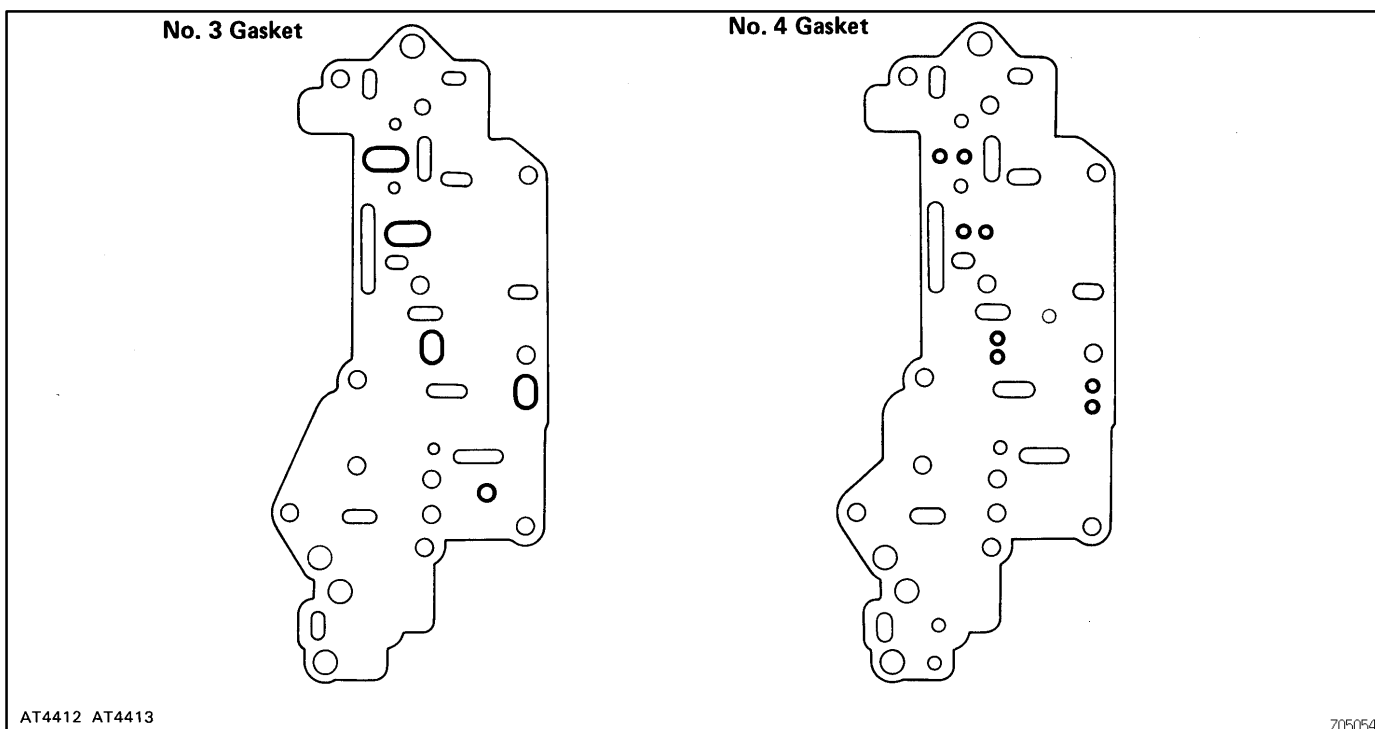

AT4412 AT4413

Z05054

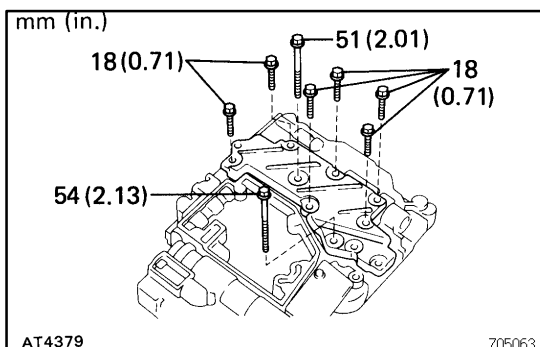

AT4379

Z05063

(d) Install the lower valve body cover.

(e) Install and tighten the 8 bolts.

HINT: Each bolt length (mm, in.) is indicated in the illustration.

Torque: 5.4 N·m (55 kgf·cm, 48 in.-lbf)

AT-84

AUTOMATIC TRANSMISSION - VALVE BODY

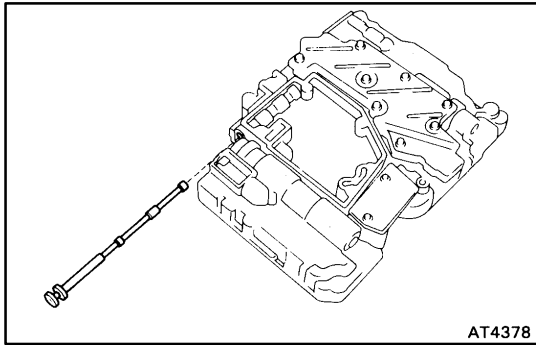

10. INSTALL MANUAL VALVE

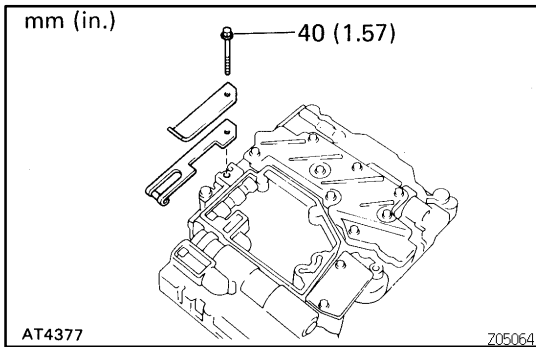

11. INSTALL DETENT SPRING

HINT: Bolt length (mm, in.) is indicated in the illustration.

Torque: 5.4 N·m (55 kgf·cm, 48 in.-lbf)

12. MAKE SURE MANUAL VALVE MOVES SMOOTHLY

FRONT UPPER VALVE BODY COMPONENTS

AT0BR-03

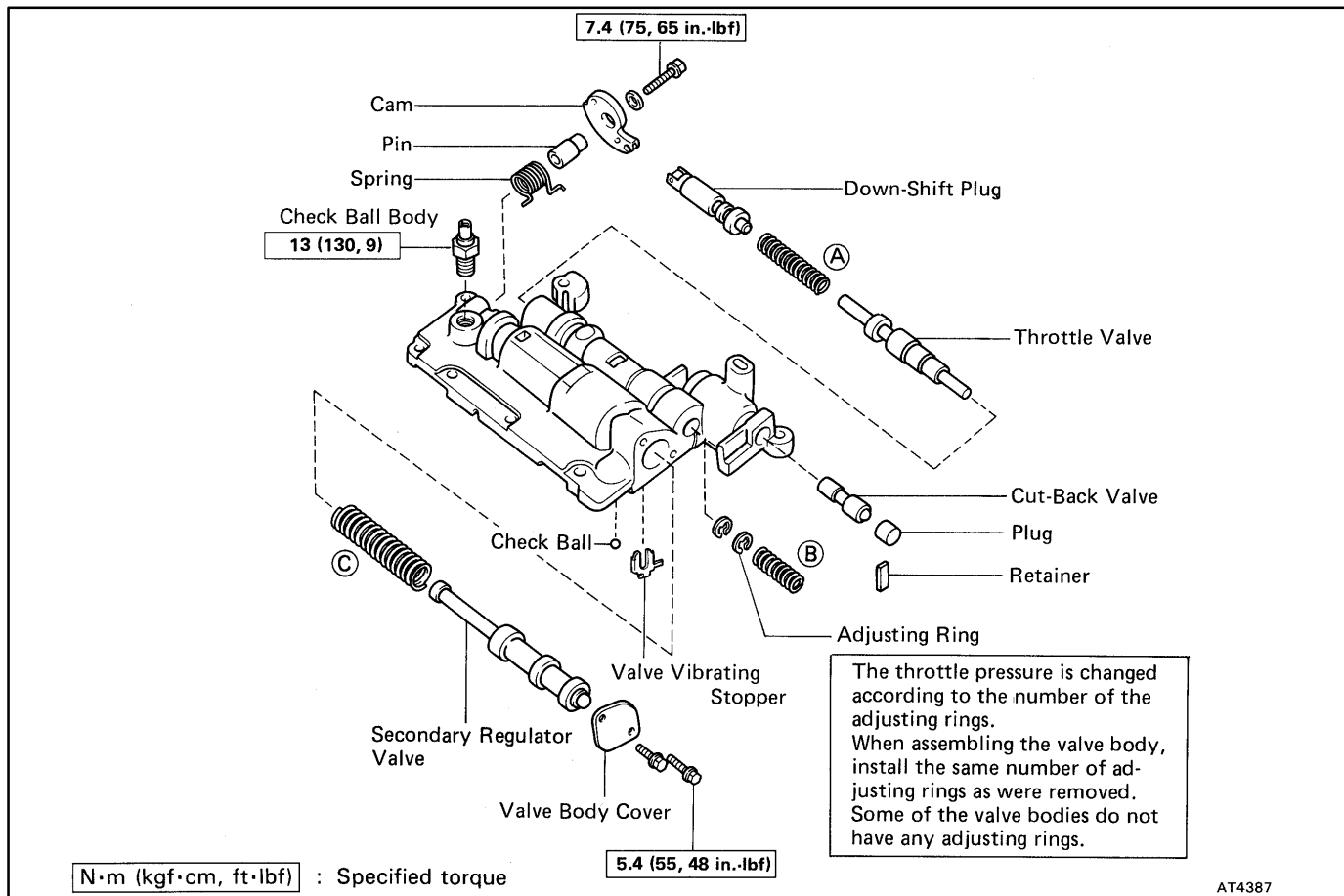

VALVE BODY SPRINGS SPECIFICATIONS

HINT: During reassembly, please refer to the spring specifications below to help you to differentiate between the different springs.

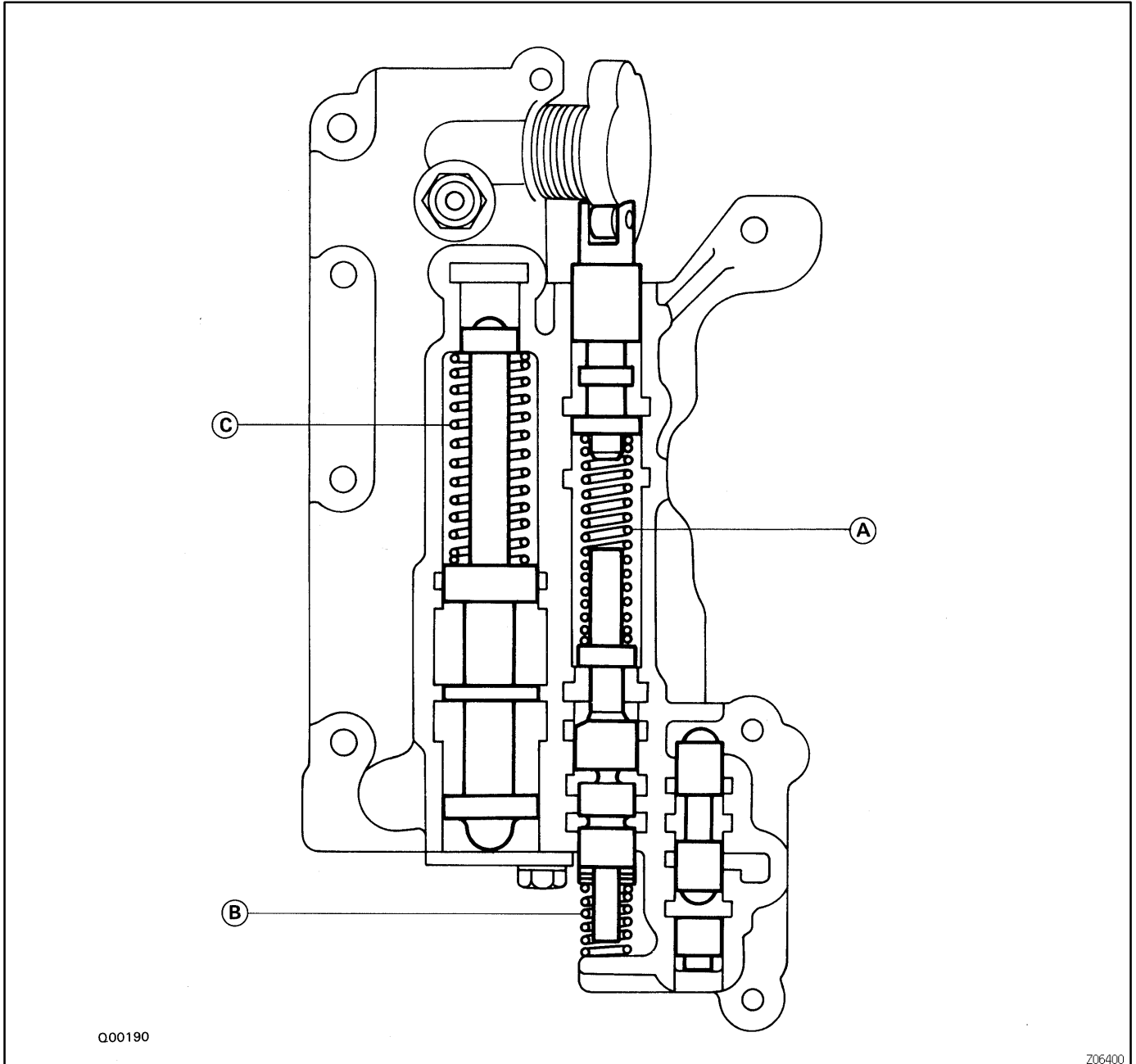

Mark	Name (Color)	Free length / Outer diameter		Total No. of coils
		mm	(in.)	
(A)	Down-shift plug (Purple)	39.8 (1.567)	10.8 (0.425)	13.5
(B)	Throttle valve (None)	21.9 (0.862)	8.6 (0.339)	10.0
(C)	Secondary regulator valve (Green)	71.3 (2.807)	17.4 (0.685)	17.0

RETAINER, STOPPER AND CHECK BALL LOCATION

1. RETAINER AND STOPPER

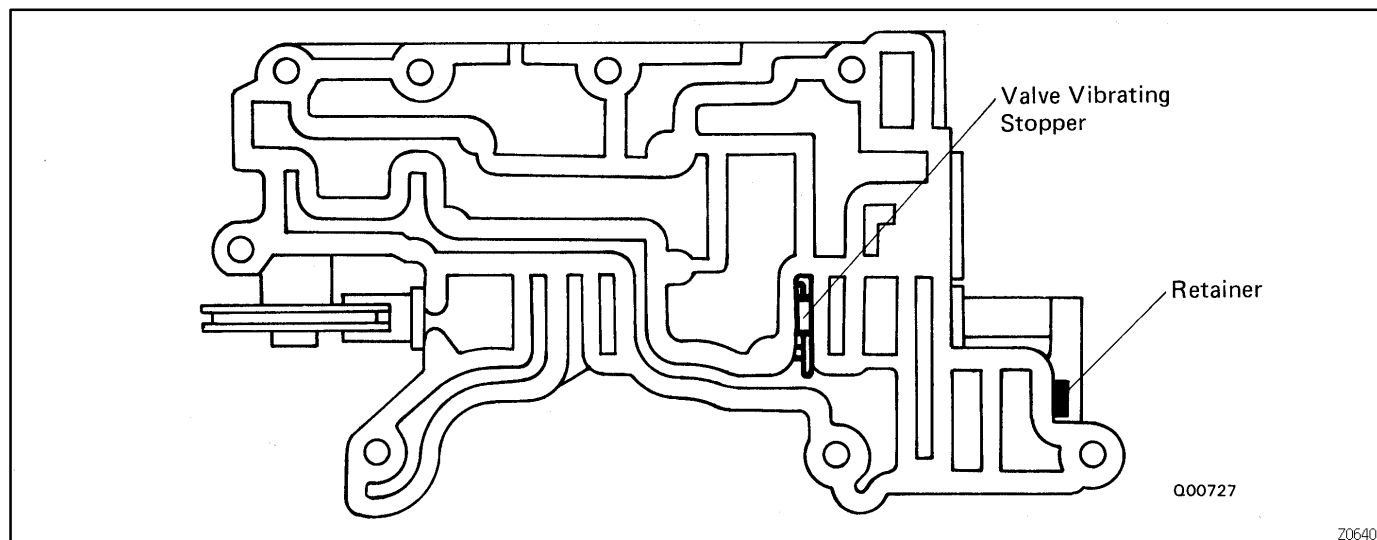

Retainer	Height / Width / Thickness	mm (in.)
Cut-back valve	19.0 (0.748) / 5.0 (0.197) / 3.2 (0.126)	

2. CHECK BALL

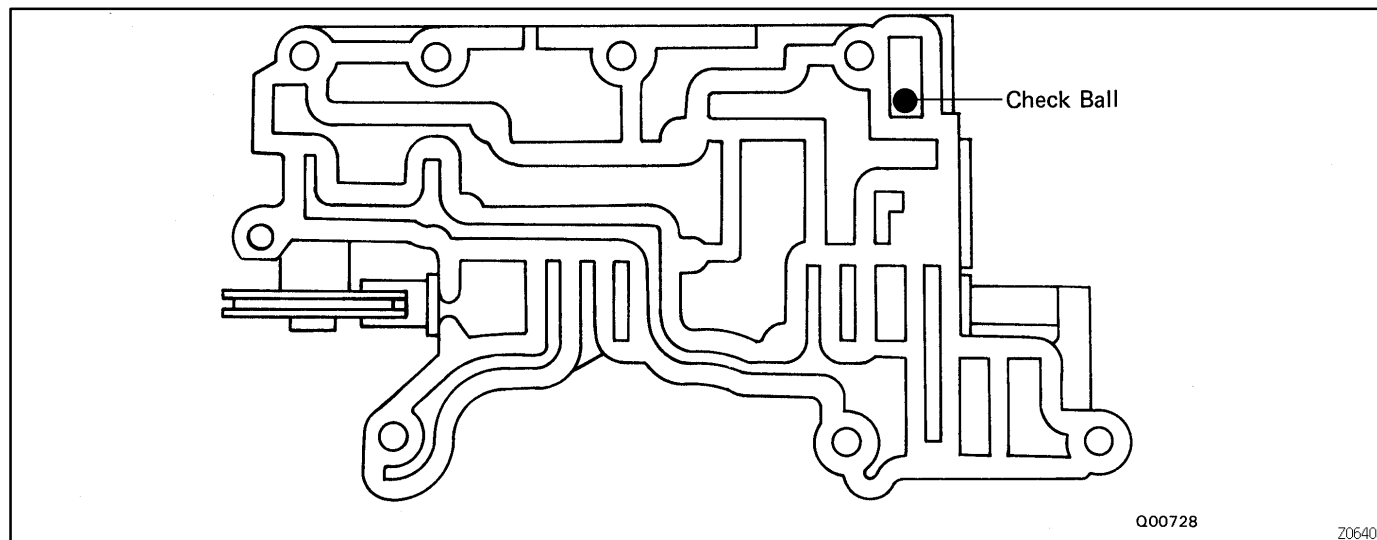

Check ball	Diameter
Rubber ball	5.54 (0.2181)

REAR UPPER VALVE BODY COMPONENTS

AT0BU-03

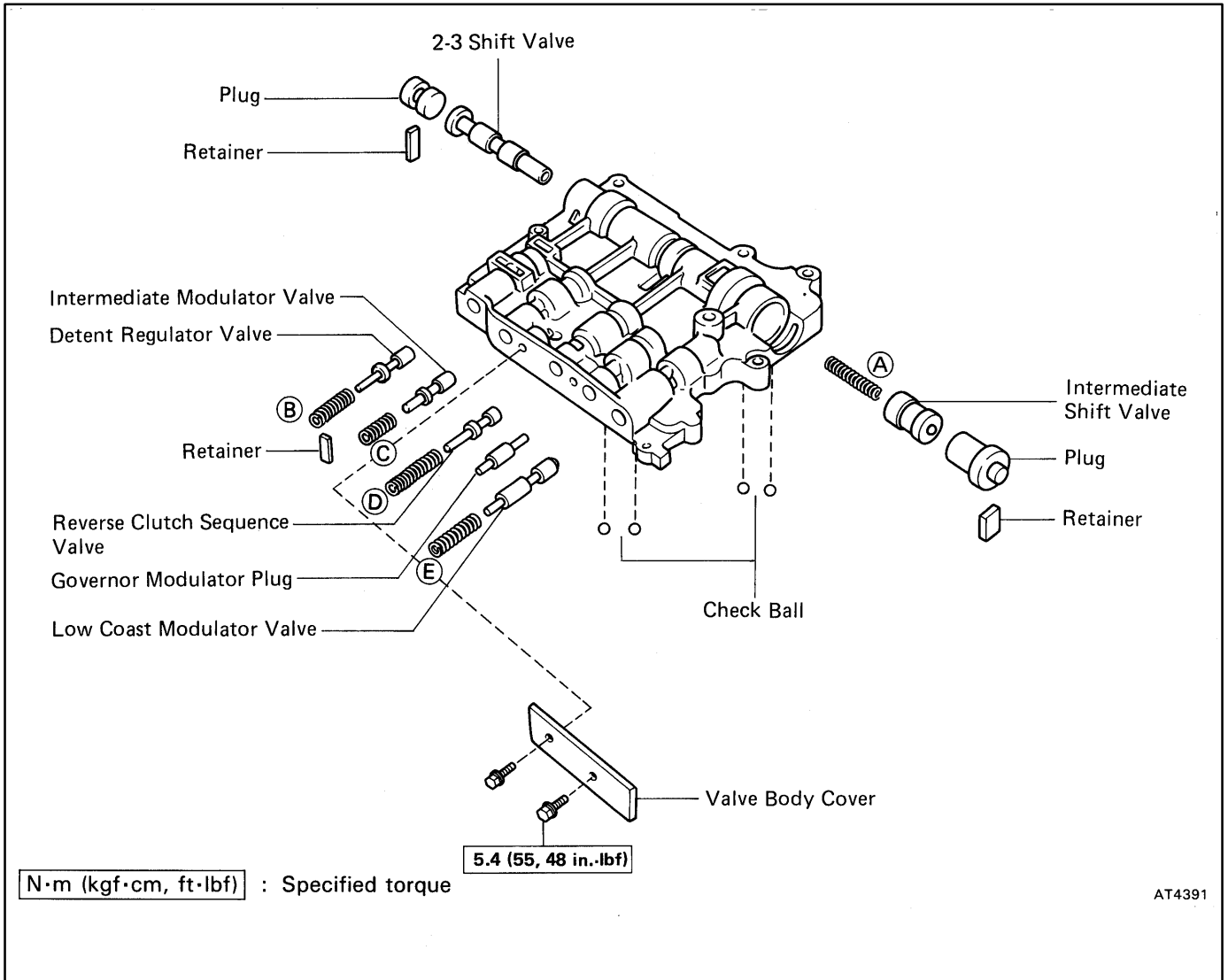

AT4391

VALVE BODY SPRINGS SPECIFICATIONS

HINT: During reassembly, please refer to the spring specifications below to help you to differentiate between the different springs.

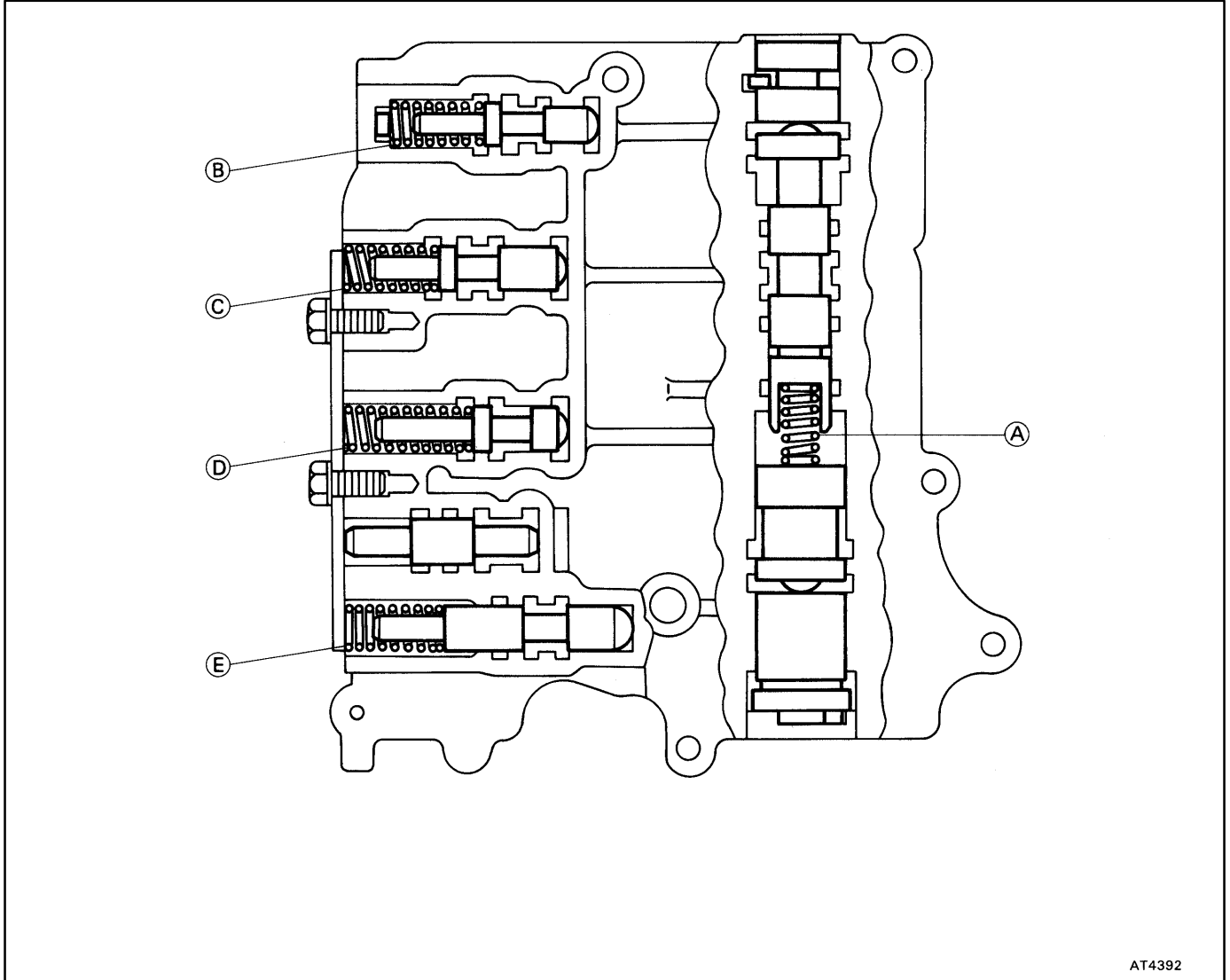

AT4392

Mark	Name (Color)	Free length / Outer diameter		Total No. of coils
		mm	(in.)	
(A)	2-3 shift valve (White)	35.1 (1.382)	9.0 (0.354)	13.7
(B)	Detent regulator valve (Red)	29.1 (1.146)	8.9 (0.350)	15.0
(C)	Intermediate modulator valve (Green)	27.3 (1.075)	9.0 (0.354)	11.5
(D)	Reverse clutch sequence valve (None)	37.6 (1.480)	9.2 (0.362)	16.5
(E)	Low coast modulator valve (None)	42.4 (1.669)	9.2 (0.362)	17.0

AT-90

AUTOMATIC TRANSMISSION - REAR UPPER VALVE BODY

AT0BW-03

RETAINERS AND CHECK BALLS LOCATION

1. RETAINER

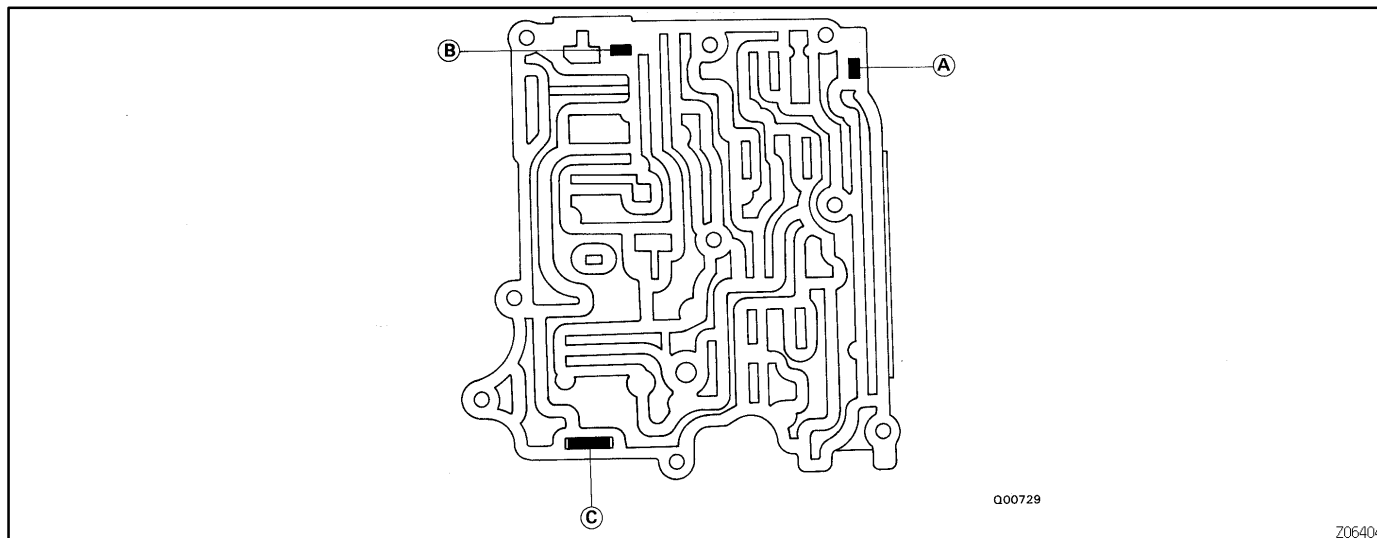

Mark	Retainer	Height / Width / Thickness	
		mm (in.)	
(A)	Detent regulator valve	21.2 (0.835) / 5.0 (0.197) / 3.2 (0.126)	
(B)	2-3 shift valve	14.0 (0.551) / 5.0 (0.197) / 3.2 (0.126)	
(C)	Intermediate shift valve	14.0 (0.551) / 5.0 (0.197) / 3.2 (0.126)	

2. CHECK BALL

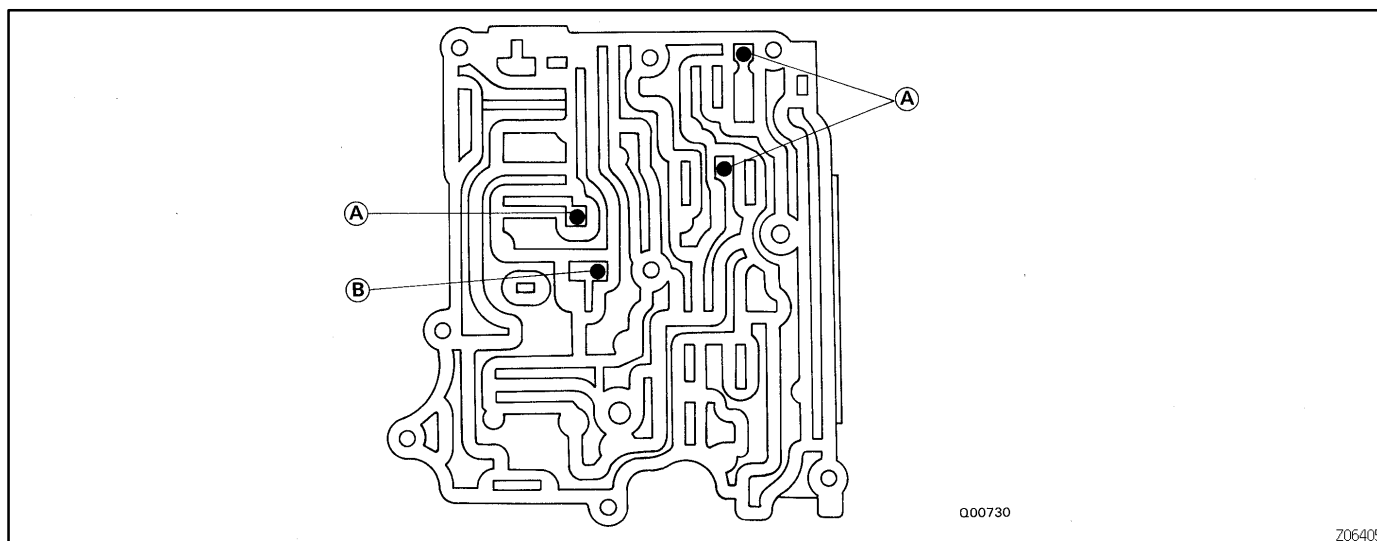

Mark	Check ball	Diameter
		mm (in.)
(A)	Rubber ball	5.54 (0.2181)
(B)	Steel ball	5.56 (0.2189)

VALVE BODY SPRINGS SPECIFICATIONS

HINT: During reassembly, please refer to the spring specifications below to help you to differentiate between the different springs.

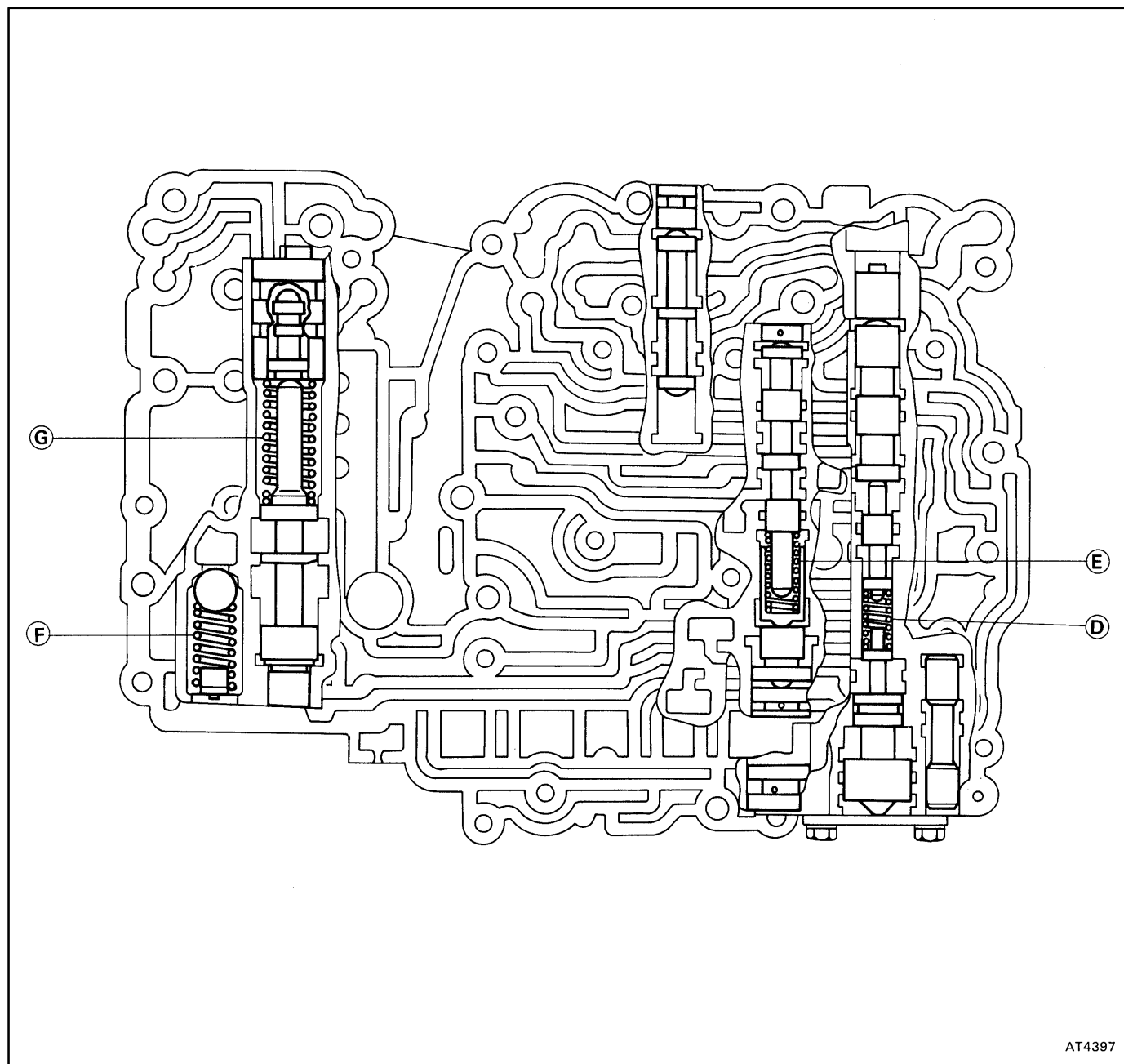

AT4397

Mark	Name (Color)	Free length / Outer diameter		Total No. of coils
		mm	(in.)	
(A)	Check ball (None)	13.7	(0.539) / 10.5 (0.413)	10.0
(B)	Cooler by-pass valve (Orange)	28.9	(1.138) / 13.8 (0.543)	8.5
(C)	Check ball (None)	20.0	(0.787) / 5.0 (0.197)	18.0
(D)	1-2 shift valve (None)	34.6	(1.362) / 7.6 (0.299)	15.0
(E)	3-4 shift valve (Orange)	33.7	(1.327) / 10.6 (0.417)	16.5
(F)	Pressure relief valve (None)	32.1	(1.264) / 13.1 (0.516)	11.0
(G)	Primary regulator valve (White)	55.2	(2.173) / 17.0 (0.669)	12.5

RETAINERS, CHECK BALLS AND SPRINGS LOCATION

1. RETAINER

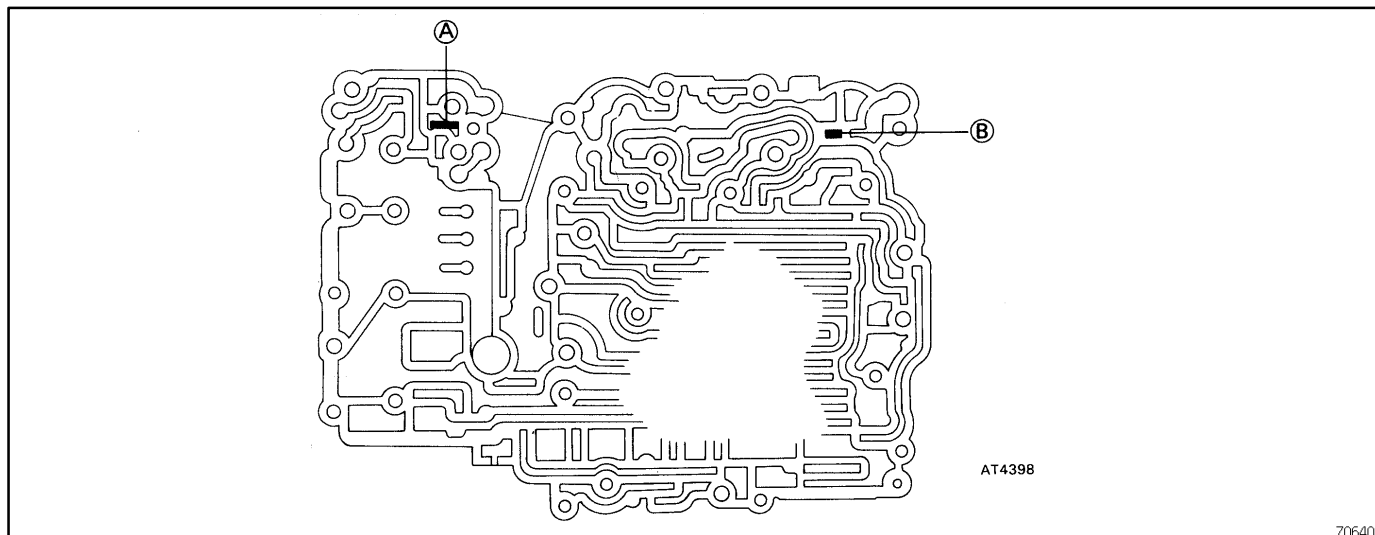

Mark	Retainer	Height / Width / Thickness mm (in.)
(A)	Primary regulator valve	17.5 (0.689) / 14.0 (0.551) / 3.2 (0.126)
(B)	1-2 shift valve	19.0 (0.748) / 14.0 (0.551) / 3.2 (0.126)

2. CHECK BALL AND SPRING

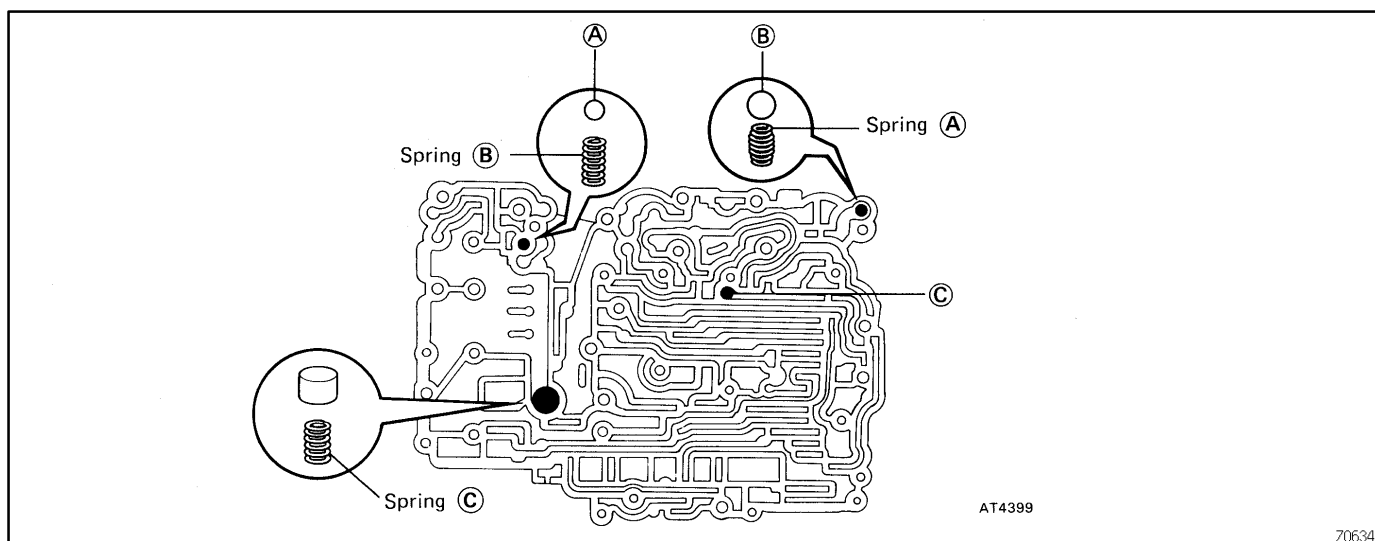

Mark	Check ball	Diameter mm (in.)
(A)	Rubber ball	6.35 (0.2500)
(B)	Plastic ball	9.53 (0.3752)
(C)	Rubber ball	5.54 (0.2181)

GOVERNOR BODY COMPONENTS

AT0C0-02

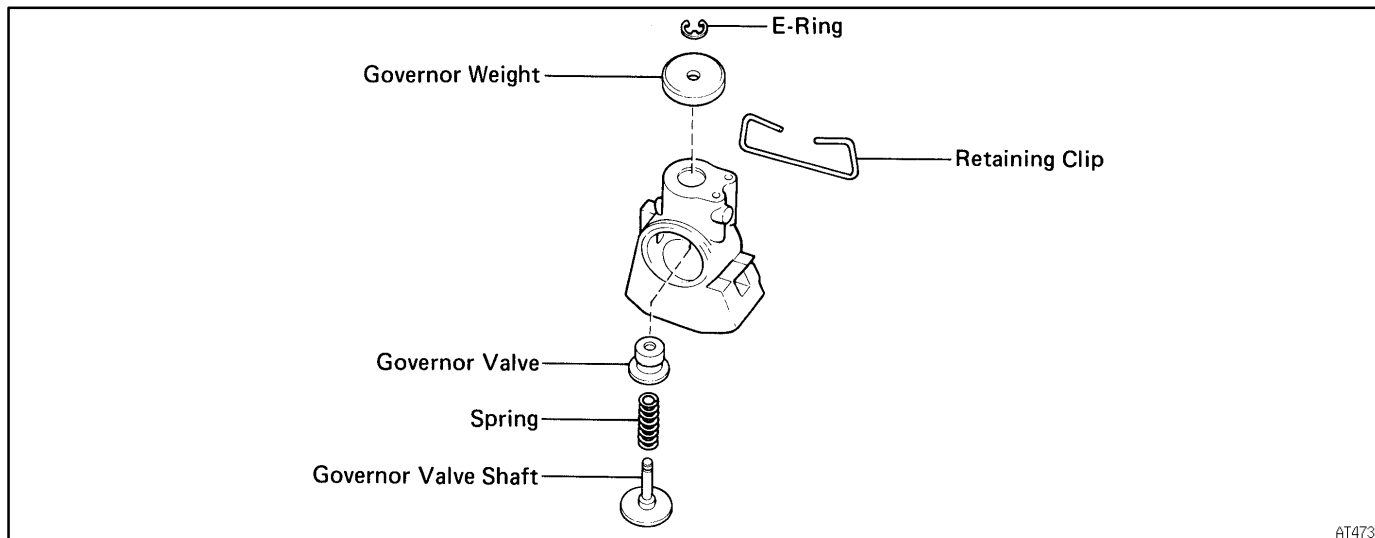

AT4739

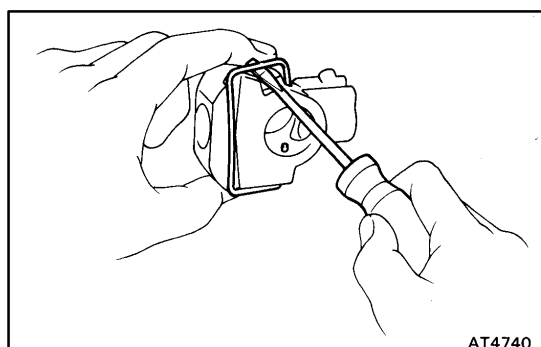

AT4740

GOVERNOR BODY DISASSEMBLY

AT0C1-02

1. REMOVE RETAINING CLIP

Using a screwdriver, remove the retaining clip.

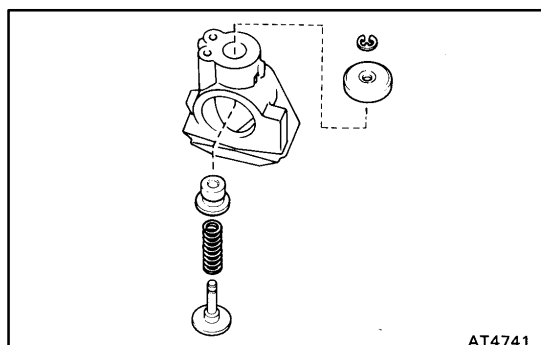

AT4741

2. DISASSEMBLE GOVERNOR VALVE

- (a) Using a screwdriver, remove the E-ring.
- (b) Remove the governor weight.
- (c) Remove the governor valve shaft, spring and governor valve.

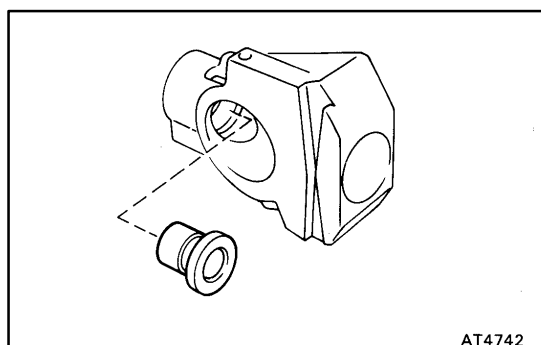

AT4742

GOVERNOR BODY ASSEMBLY

AT0C2-02

1. ASSEMBLE GOVERNOR VALVE

- (a) Insert the governor valve into the governor body.

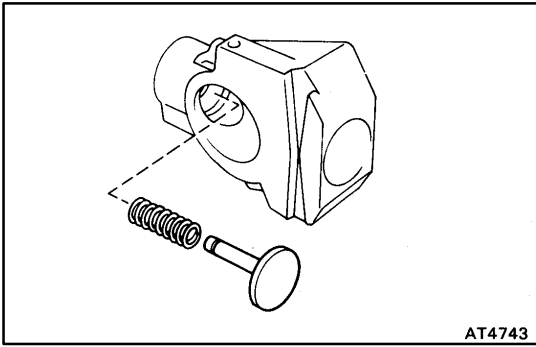

(b) Insert the spring and governor valve shaft into the governor body.

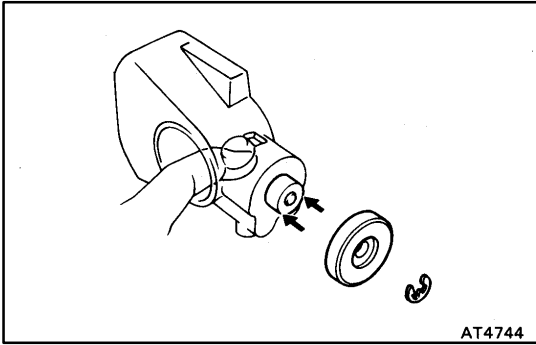

(c) Install the governor weight and E-ring.

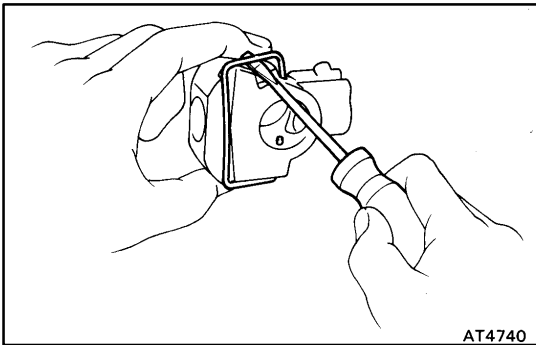

2. INSTALL RETAINING CLIP

AT-96

AUTOMATIC TRANSMISSION - TRANSMISSION CASE

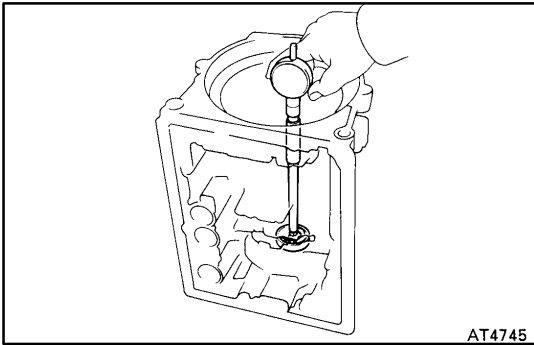

TRANSMISSION CASE TRANSMISSION CASE INSPECTION

AT0C3-03

INSPECT TRANSMISSION CASE BUSHING

Using a cylinder gauge, measure the inside diameter of the transmission case rear bushing.

Maximum inside diameter:

38.19 mm (1.5035 in.)

If the inside diameter is greater than the maximum, replace the transmission case.

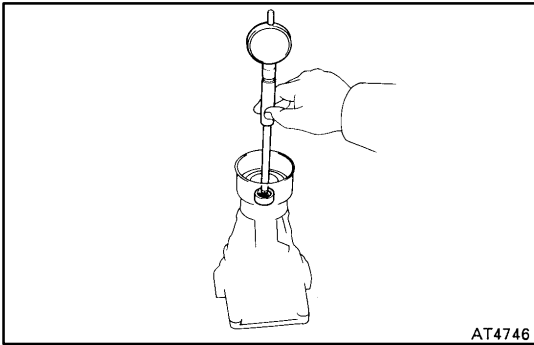

EXTENSION HOUSING EXTENSION HOUSING INSPECTION

AT0C4-03

INSPECT EXTENSION HOUSING BUSHING

Using a cylinder gauge, measure the inside diameter of the extension housing bushing.

Maximum inside diameter:

38.09 mm (1.4996 in.)

If the inside diameter is greater than the maximum, replace the extension housing.

COMPONENT PARTS INSTALLATION

Disassembly, inspection and assembly of each component group have been indicated in the preceding chapter. Before assembly, make sure again that all component groups are assembled correctly. If something wrong is found in a certain component group during assembly, inspect and repair this group immediately.

Recommended ATF:

DEXRON® II

GENERAL INSTALLATION NOTES

1. The automatic transmission is composed of highly precision-finished parts, necessitating careful inspection before assembly because even a small nick could cause fluid leakage and affect performance.
2. Before assembling new clutch discs, soak them in automatic transmission fluid for at least 15 minutes.
3. Apply automatic transmission fluid on sliding or rotating surfaces of parts before assembly.
4. Use petroleum jelly to keep small parts in their places.
5. Do not use adhesive cements on gaskets and similar parts.
6. When assembling the transmission, be sure to use new gaskets and O-rings.
7. Dry all parts with compressed air, never use shop rags.

Bearing and Race Diameters

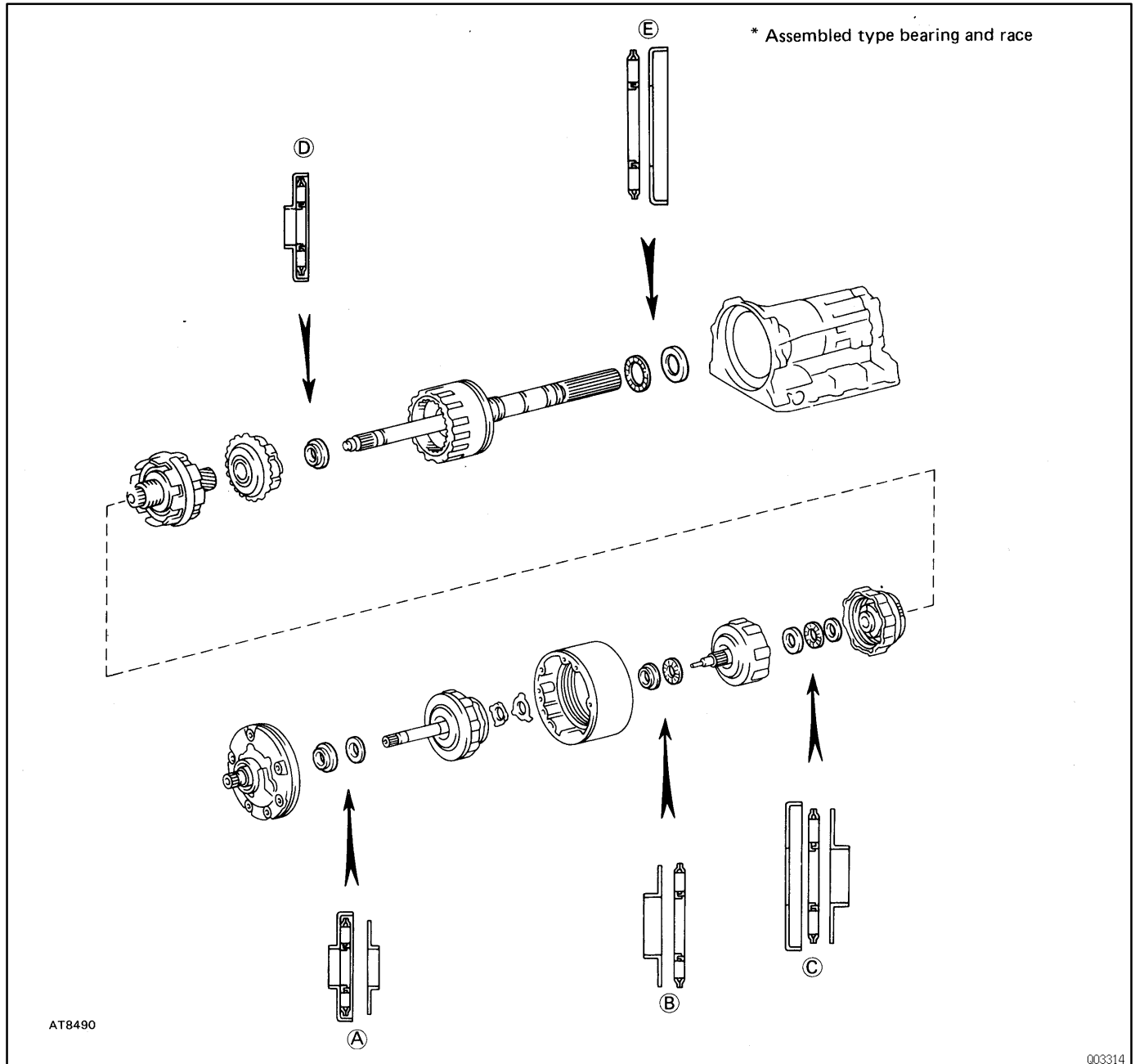

Mark	Front Race Diameter	Thrust Bearing Diameter	Rear Race Diameter
	Inside / Outside mm (in.)	Inside / Outside mm (in.)	Inside / Outside mm (in.)
(A)	-	24.3 (0.957) / 43.2 (1.701)	24.3 (0.957) / 39.1 (1.539)
(B)	24.1 (0.949) / 37.3 (1.469)	23.4 (0.921) / 37.5 (1.476)	-
(C)	30.1 (1.185) / 48.5 (1.909)	28.4 (1.118) / 46.4 (1.827)	27.6 (1.087) / 44.5 (1.752)
(D)	-	24.1 (0.949) / 44.3 (1.744)	-
(E)	-	38.2 (1.504) / 55.2 (2.173)	39.2 (1.543) / 57.5 (2.264)

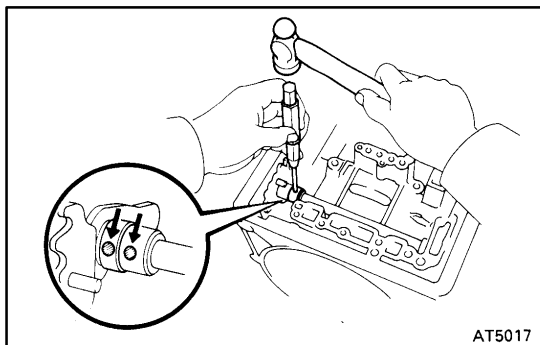

BASIC SUBASSEMBLY REASSEMBLY

1. INSTALL MANUAL VALVE LEVER, SHAFT AND OIL SEALS

- (a) Using SST, drive in 2 new oil seals as far as they will go. SST 09350-20015 (09361-30010)
- (b) Coat the oil seal lips with MP grease.
- (c) Assemble a new spacer to the manual valve lever.
- (d) Install the manual valve lever shaft to the transmission case through the manual valve lever.

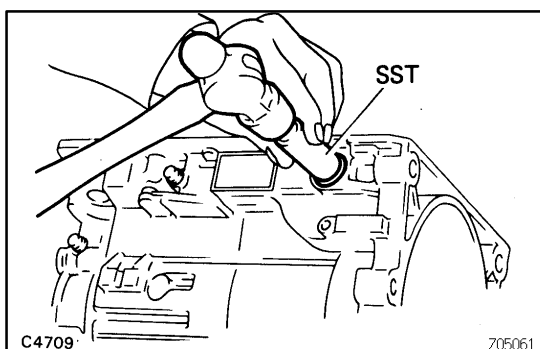
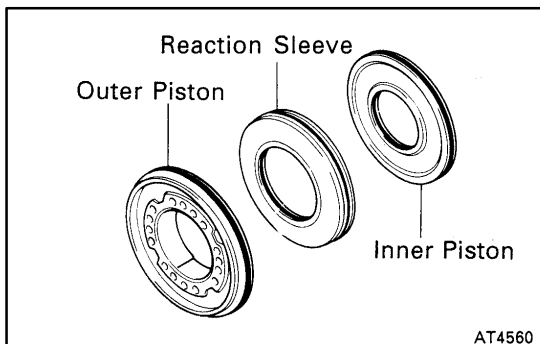

- (e) Drive in the pin to the shaft.

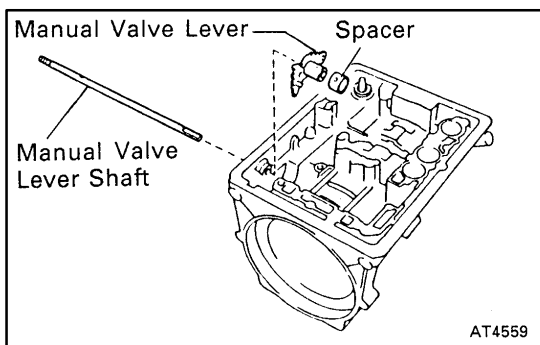

- (f) Match the spacer hole to the lever calking hollow and calk the spacer to the lever.
- (g) Make sure the manual valve lever shaft turns smoothly.

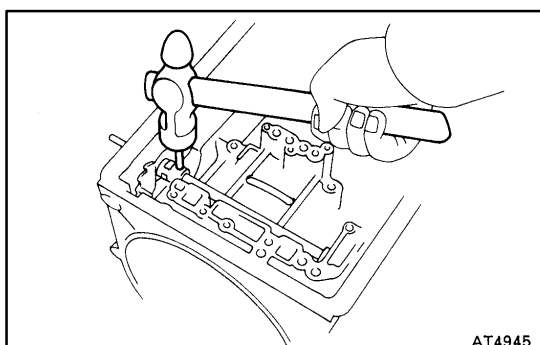

2. INSTALL COMPONENTS OF NO.3 BRAKE PISTON

- (a) Coat 5 new O-rings to the inner piston, reaction sleeve and outer piston.
NOTICE: The thinner O-ring goes on the outside of the reaction sleeve.
- (c) Assemble the inner piston, reaction sleeve and outer piston.

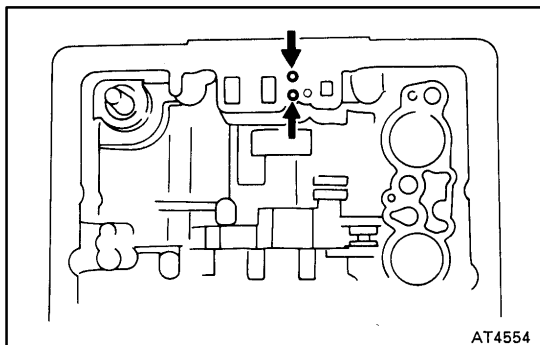

- (d) Stand the transmission case up.
- (e) Being careful not to damage the O-rings, press in the assembled pistons into the transmission case with hand.

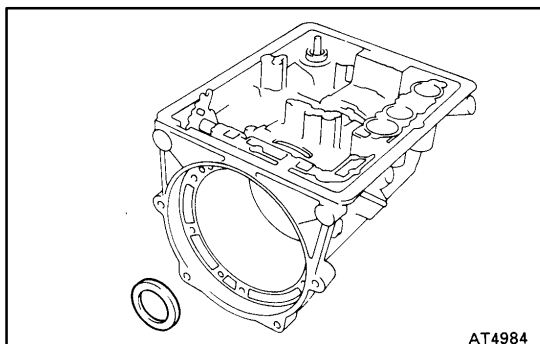

- (f) Place the piston return spring onto the outer piston.

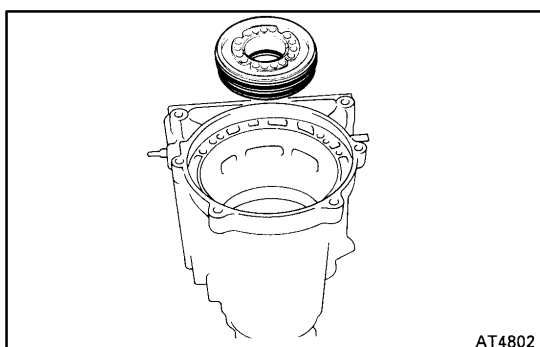

- (g) Set SST as shown, and compress the return springs with SST.
SST 09350-20015 (09369-20040)
- (h) Install the snap ring with a snap ring expander. Be sure the end gap of the snap ring is not aligned with the spring seat claw.

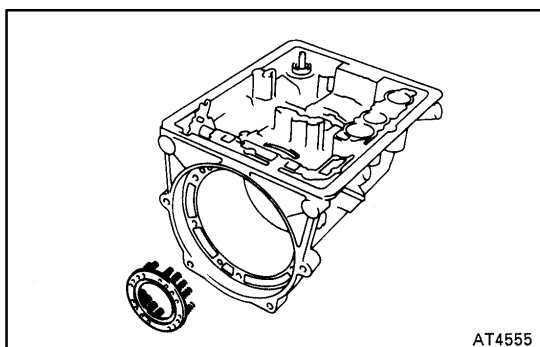

3. CHECK NO.3 BRAKE PISTONS MOVING

Make sure the No.3 brake pistons move smoothly when applying and releasing the compressed air into the transmission case.

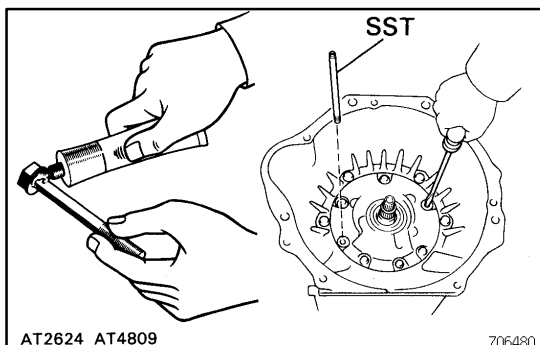

4. INSTALL RACE

Coat the race with petroleum jelly and install it onto the transmission case.

Race diameter
mm (in.)

	Inside	Outside
Race	39.2 (1.543)	57.5 (2.264)

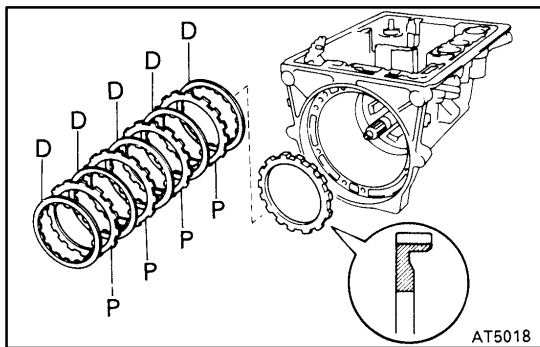

5. INSTALL BRAKE APPLY TUBE

Install the tube, aligning its locking tab with the cutout of the case.

HINT: Make sure that the lips of the tube end are completely inserted into the outer piston.

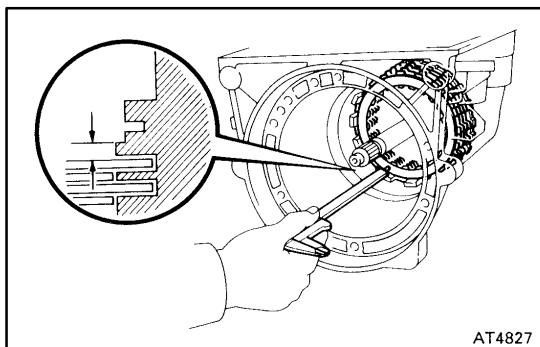

6. INSTALL REAR PLANETARY GEAR UNIT AND OUTPUT SHAFT

(a) Coat the 2 bearings with petroleum jelly and install them onto the rear planetary gear unit.

Bearings diameter
mm (in.)

	Inside	Outside
Bearing	38.2 (1.504)	55.2 (2.173)

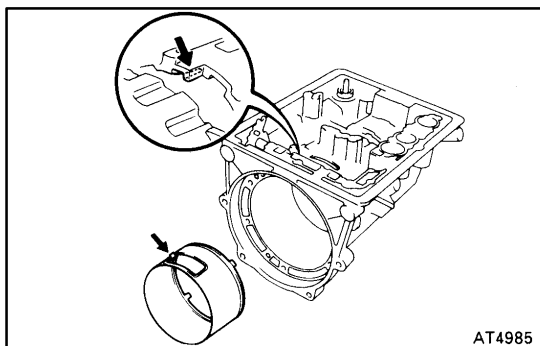

(b) Install the rear planetary gear unit to the transmission case.

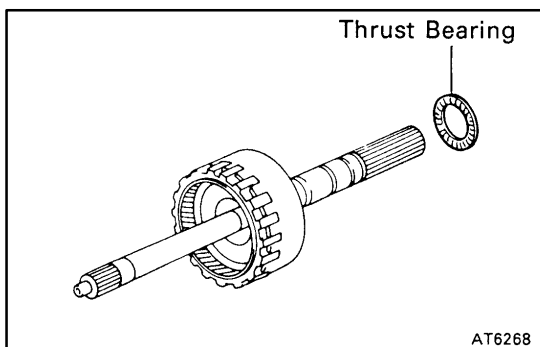

7. INSTALL PRESSURE PLATE, DISCS AND PLATES

(a) Install the pressure plate, the flat surface facing forward.

(b) Install the 5 discs and 4 plates.

Install in order: P = Plate D = Disc
D-P-D-P-D-P-D-P-D

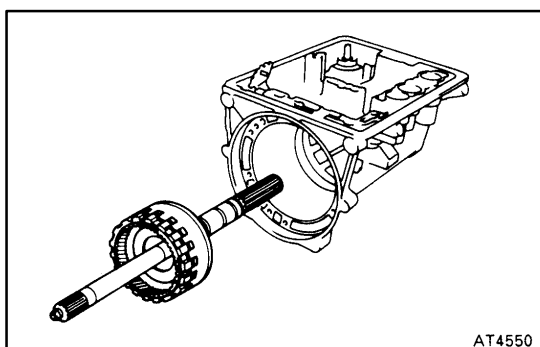

8. CHECK PACK CLEARANCE OF NO.3 BRAKE

Using calipers, measure the clearance between the disc and transmission case.

Clearance:
0.61 - 2.64 mm (0.0240 - 0.1039 in.)

If the values are non-standard, check for an improper installation.

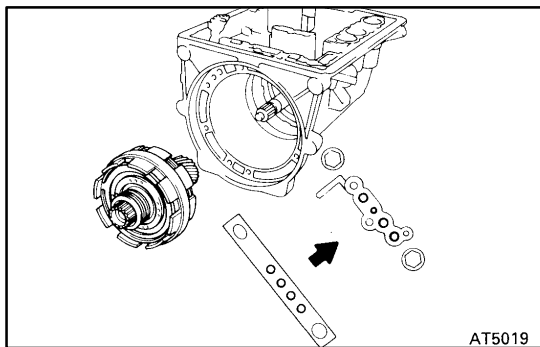

9. INSTALL FRONT PLANETARY GEAR UNIT

- (a) Remove the one-way clutch inner race from the planetary gear unit.
- (b) Install the front planetary gear unit.
HINT: Mesh the splines of the planetary gear with the flukes of the discs by rotating and pushing the planetary gear.

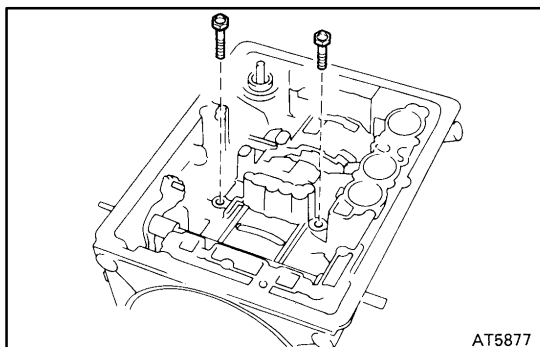

- (c) Position the notched tooth of the inner race toward the valve body side of the case. Push it into place.
HINT: The inner race is correctly installed if the snap ring groove is fully visible.

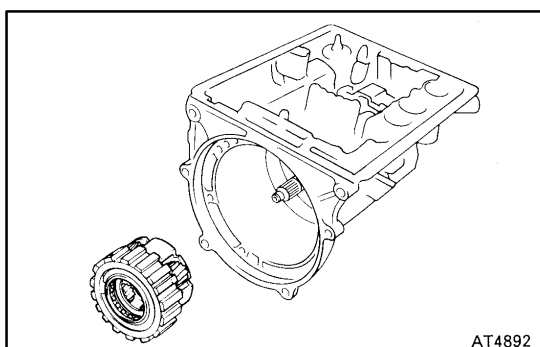

- (d) Using a screwdriver, install the snap ring.

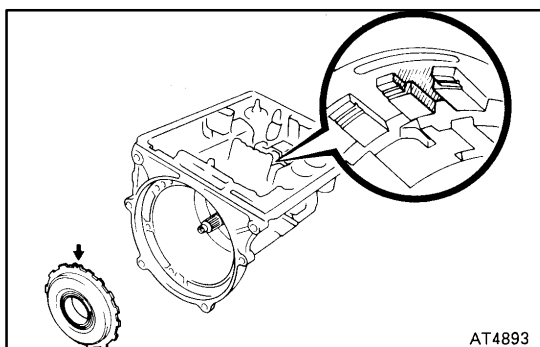

10. INSTALL CENTER SUPPORT

- (a) Aim the bolt and oil holes of the center support toward the valve body side, and align them with the bolt and oil holes of the transmission case and insert.

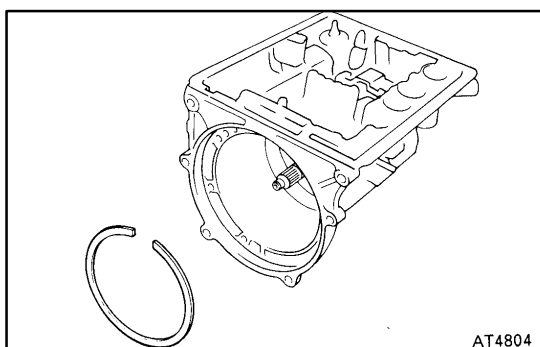

- (b) Install the 2 bolts with the wave washers, and tighten the bolts.
HINT: First tighten the accumulator piston side.
Torque: 25 N·m (260 kgf·cm, 19 ft·lbf)

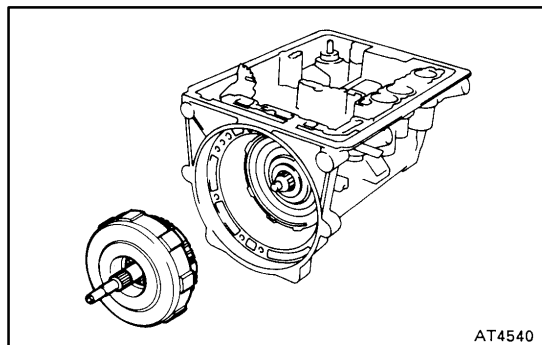

11. INSTALL REAR CLUTCH

(a) Coat the race with petroleum jelly and install it onto the rear clutch.

Race diameter
mm (in.)

	Inside	Outside
Race	27.6 (1.087)	44.5 (1.752)

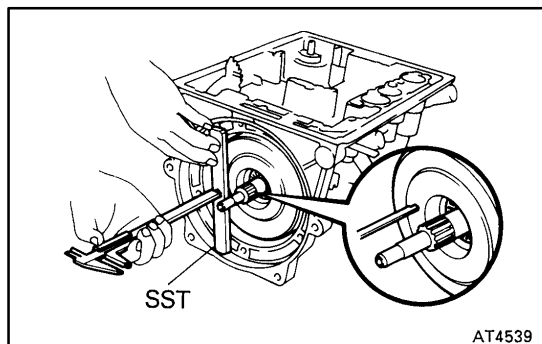

(b) Install the rear clutch.

HINT:

- ★ Mesh the splines of the rear clutch with the flukes of the disc by rotating and pushing the rear clutch.
- ★ If the rear clutch is fully meshed with the center support, the splined center of the clutch will be flush with the end of the sun gear shaft.

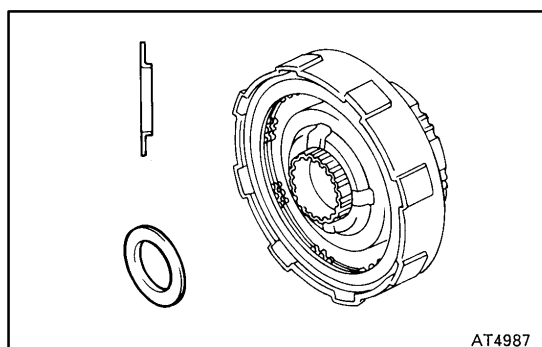

12. INSTALL FRONT CLUTCH

(a) Coat the bearings and race with petroleum jelly and install them onto the front clutch.

Bearing and race diameter
mm (in.)

	Inside	Outside
Bearing (Front)	23.4 (0.921)	37.5 (1.476)
Race	30.1 (1.185)	48.5 (1.909)
Bearing (Rear)	28.4 (1.118)	46.4 (1.827)

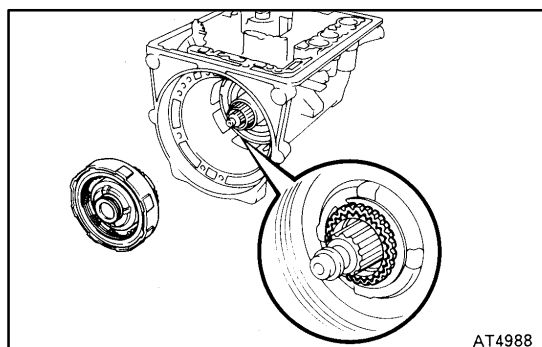

(b) Install the front clutch.

HINT: Mesh the splines of the front clutch with the flukes of the discs by rotating and pushing the front clutch.

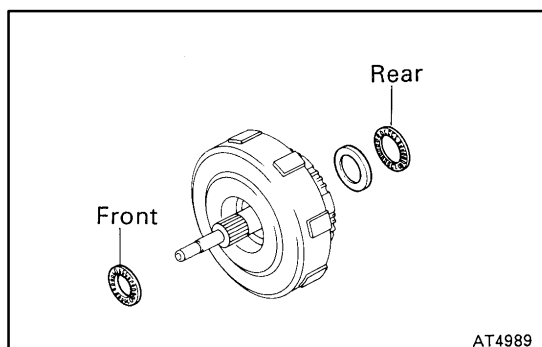

13. MEASURE INSTALLATION DISTANCE OF FRONT CLUTCH

(a) Place SST on the transmission case.

SST 09350-20015 (09370-12010)

(b) Using calipers, measure the distance between the tops of SST and the clutch drum.

If the distance corresponds to that during disassembly, the front clutch is installed correctly.

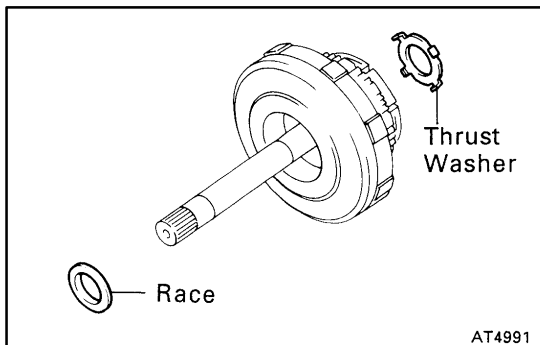

14. INSTALL OVERDRIVE CASE

- (a) Finger tighten the 2 SSTs on the transmission case.
SST 09350-20015 (09362-30011)
HINT: Remove the SST after installation of the oil pump.

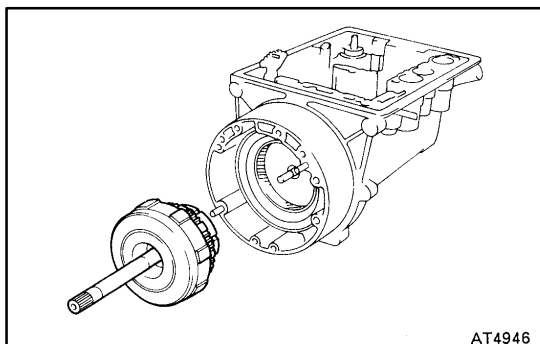

- (b) Coat the races with petroleum jelly and install them onto the overdrive case.

Races diameter
mm (in.)

	Inside	Outside
Race (Front)	23.0 (0.906)	48.0 (1.890)
Race (Rear)	24.1 (0.946)	37.3 (1.469)

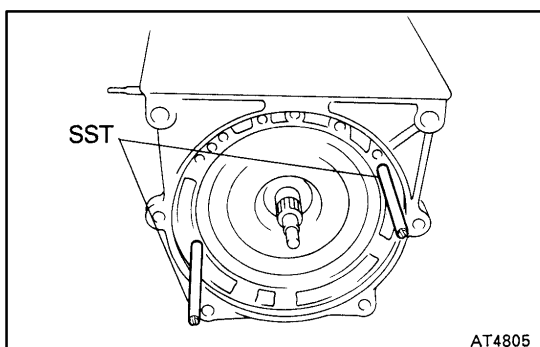

- (c) Insert the overdrive case gently through the 2 guide bolts (SST) with cutout portion of the case facing the valve body side.

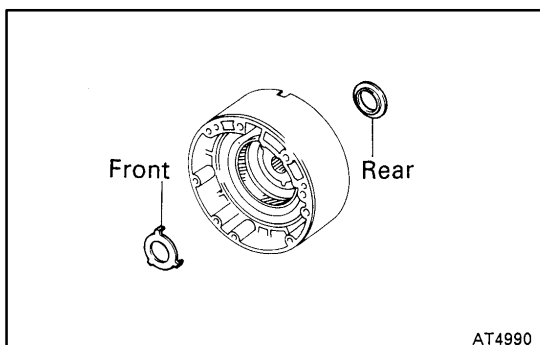

15. INSTALL OVERDRIVE PLANETARY GEAR UNIT WITH OVERDRIVE DIRECT CLUTCH AND ONE-WAY CLUTCH

- (a) Coat the thrust washer with petroleum jelly and install it onto the overdrive planetary gear.
(b) Coat the race with petroleum jelly and install it onto the overdrive planetary gear.

Race diameter
mm (in.)

	Inside	Outside
Race	24.3 (0.957)	39.1 (1.539)

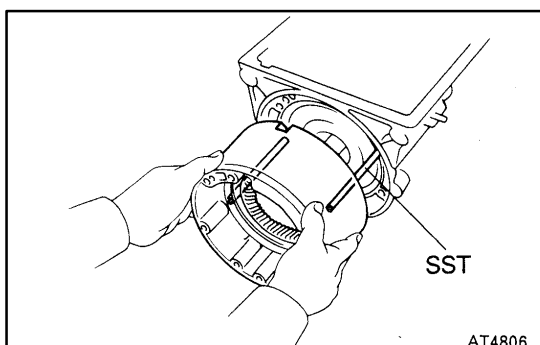

- (c) Install the overdrive planetary gear with the overdrive direct clutch and one-way clutch.
HINT: Mesh the splines of the overdrive planetary gear with the flukes of the discs by rotating and pushing the overdrive planetary gear.

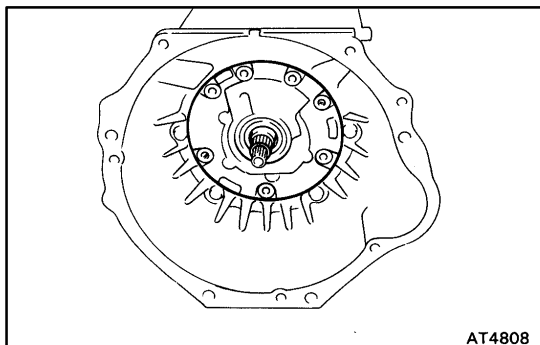

16. MEASURE INSTALLATION DISTANCE OF OVER-DRIVE DIRECT CLUTCH

- (a) Place SST on the overdrive case.
SST 09350-20015 (09370-12010)
- (b) Using calipers, measure distance between the tops of SST and the clutch drum.
If the distance corresponds to that during disassembly, the overdrive direct clutch is installed correctly.

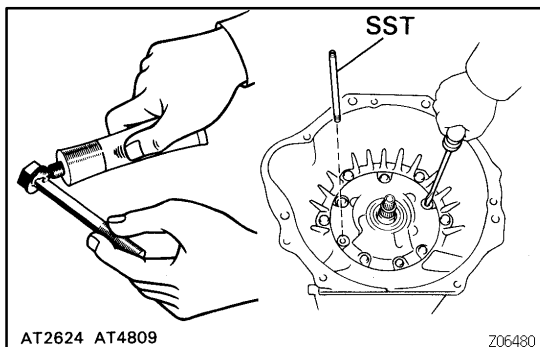

17. INSTALL TRANSMISSION HOUSING

- (a) Coat a new O-ring with ATF and install it around the overdrive case.
- (b) Install the transmission housing and 6 bolts.
- (c) Tighten the bolts.

Torque:

- 10 mm bolt 34 N·m (345 kgf·cm, 25 ft·lbf)**
- 12 mm bolt 57 N·m (580 kgf·cm, 42 ft·lbf)**

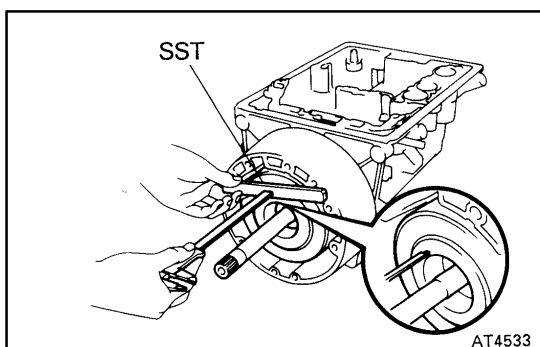

18. INSTALL OIL PUMP

- (a) Coat the assembled bearing and race with petroleum jelly and install it onto the oil pump.

Assembled bearing and race diameter
mm (in.)

	Inside	Outside
Bearing and race	24.3 (0.957)	43.2 (1.701)

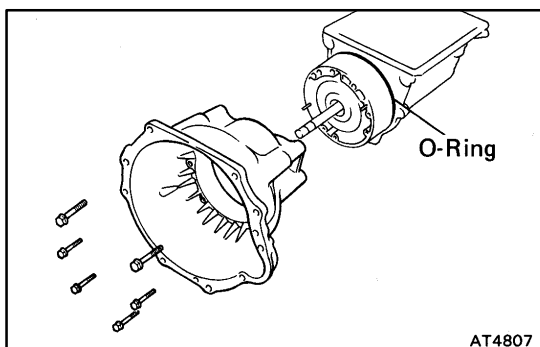

- (b) Coat a new O-ring with ATF and install it around the pump body.
- (c) Install the oil pump gently through the 2 guide bolts (SST).

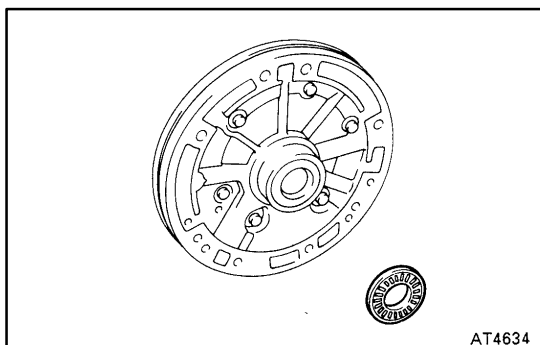

- (d) Apply sealant to the bolt heads.

Sealant:

Part No. 08833-00080, THREE BOND 1344, LOCTITE 242 or equivalent

- (e) Finger tighten the 5 bolts.
- (f) Using a screwdriver, remove the 2 SST.

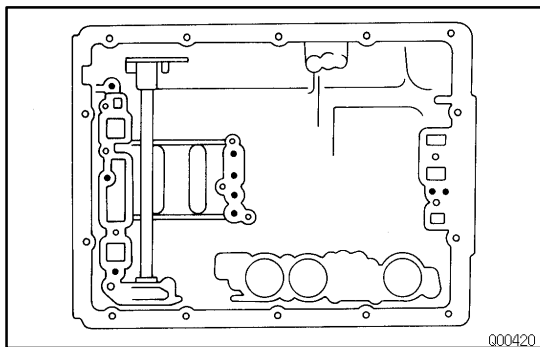

- (g) Finger tighten the 2 bolts.
Torque: 21 N·m (215 kgf·cm, 16 ft·lbf)

19. CHECK INPUT SHAFT ROTATION

Make sure the input shaft rotates smoothly.

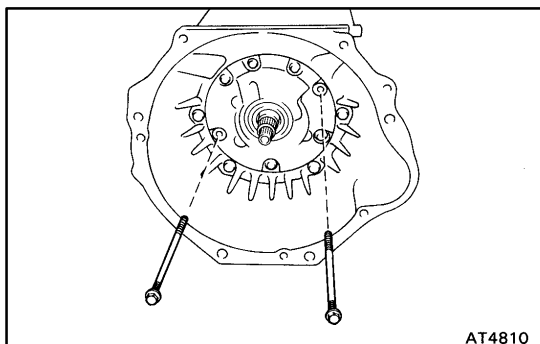

20. CHECK OUTPUT SHAFT

- (a) Using a dial indicator, measure the end play of the output shaft with hand.

End play:

0.3 - 0.9 mm (0.012 - 0.035 in.)

If the values are non-standard, check for an improper installation.

- (b) Check to see that output shaft rotates smoothly.

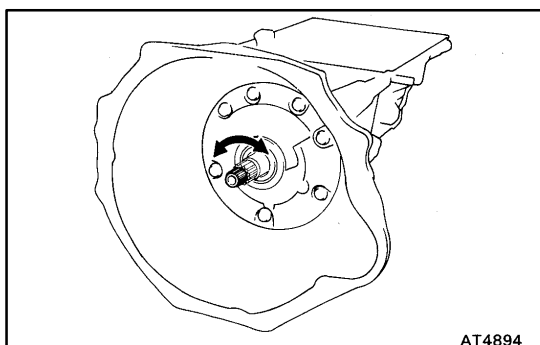

21. INDIVIDUAL PISTON OPERATION INSPECTION

Check for the sound of operation while applying compressed air into the oil holes indicated in the illustration.

- (1) O/D direct clutch
- (2) O/D brake
- (3) Rear clutch
- (4) Front clutch
- (5) No.1 brake
- (6) No.2 brake
- (7) No.3 brake

If there is no noise, disassemble and check the installation condition of the parts.

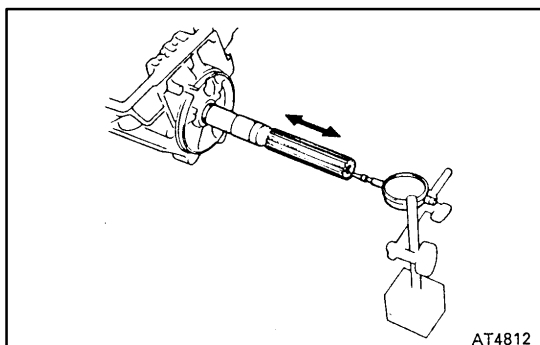

AT-108

AUTOMATIC TRANSMISSION - COMPONENT PARTS INSTALLATION

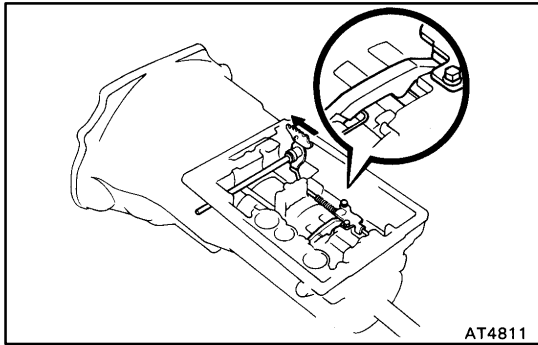

22. INSTALL PARKING LOCK PAWL AND ROD

- (a) Install the E-ring to the shaft.
- (b) Install the parking lock pawl, shaft and spring.

- (c) Connect the parking lock rod to the manual valve lever.

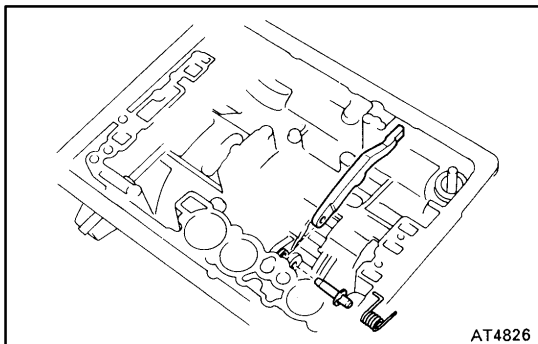

- (d) Install the parking lock pawl bracket.
- (e) Install and tighten the 2 bolts with the wave washer.
Torque: 7.4 N·m (75 kgf·cm, 65 in.-lbf)

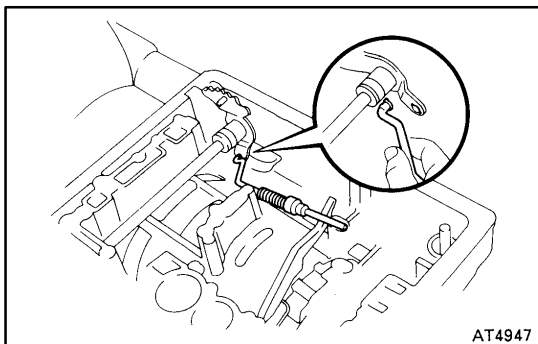

- (f) Shift the manual valve lever to the P position, and confirm the planetary ring gear is correctly locked up by the lock pawl.

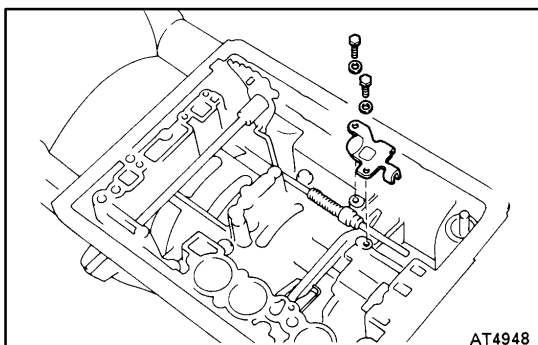

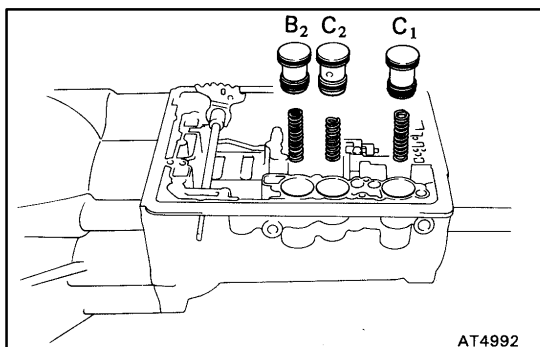

23. INSTALL ACCUMULATOR SPRINGS AND PISTONS

- (a) Coat new O-rings with ATF and install them to the pistons.
- (b) Install the 3 springs and 3 accumulator pistons to the bore.

Piston

mm (in.)

Piston	Outer diameter
C ₁	31.8 (1.252)
C ₂	31.8 (1.252)
B ₂	34.8 (1.370)

Spring dimensions

mm (in.)

Piston (Color)	Free length	Outer diameter
C ₁ (None)	64.7 (2.547)	17.5 (0.689)
C ₂ (White)	55.2 (2.173)	15.9 (0.626)
B ₂ (Purple)	66.7 (2.626)	16.4 (0.646)

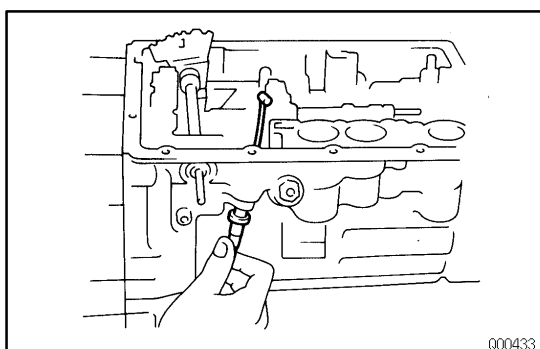

24. INSTALL THROTTLE CABLE

- (a) Coat a new O-ring with ATF and install it to the cable.
- (b) Install the cable to the case.

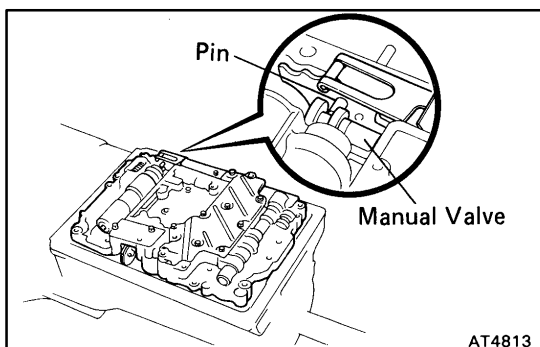

25. INSTALL VALVE BODY

- (a) Align the groove of the manual valve to the pin of the lever.

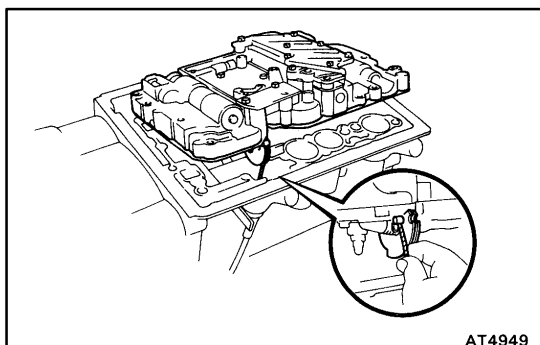

- (b) Connect the throttle cable to the cam.

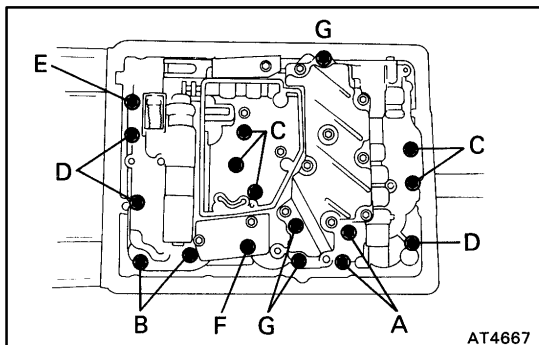

- (c) Install the 17 bolts.
 HINT: Each bolt length (mm, in.) is indicated below.
Torque: 10 N·m (100 kgf·cm, 7 ft·lbf)

Bolt length:

- A bolt 20 mm (0.79 in.)
- B bolt 25 mm (0.98 in.)
- C bolt 30 mm (1.18 in.)
- D bolt 36 mm (1.42 in.)
- E bolt 40 mm (1.57 in.)
- F bolt 47 mm (1.85 in.)
- G bolt 55 mm (2.17 in.)

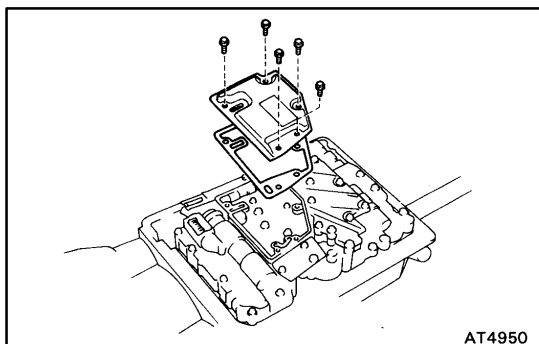

26. INSTALL OIL STRAINER

- (a) Install new gasket to the oil strainer.
- (b) Install the oil strainer to the valve body.
- (c) Install and tighten the 5 bolts.

Torque: 5.4 N·m (55 kgf·cm, 48 in.-lbf)

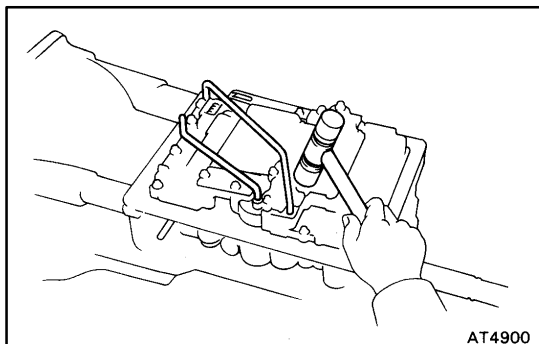

27. INSTALL OIL TUBE

Using a plastic hammer, install the 2 tubes into position.
NOTICE: Be careful not to bend or damage the tube.

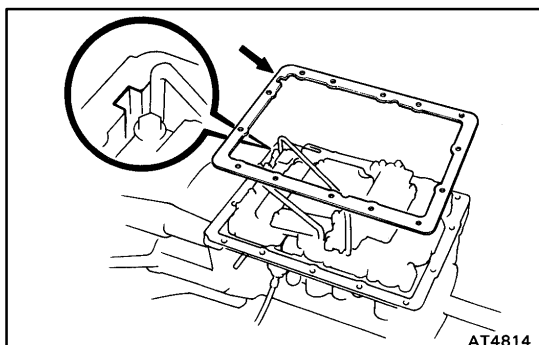

28. INSTALL OIL PAN

- (a) Install the 2 magnets in the oil pan.
NOTICE: Make sure that the magnets do not interfere with the oil tubes.
- (b) Install a new gasket to the transmission case.
HINT: Align the cut part of the gasket and case.

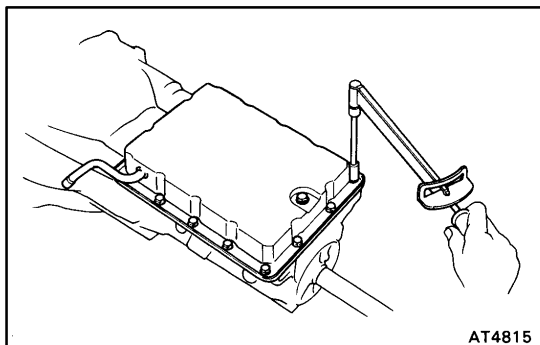

AT4815

- (c) Install and tighten the 14 bolts.
Torque: 4.4 N·m (45 kgf·cm, 39 in.-lbf)

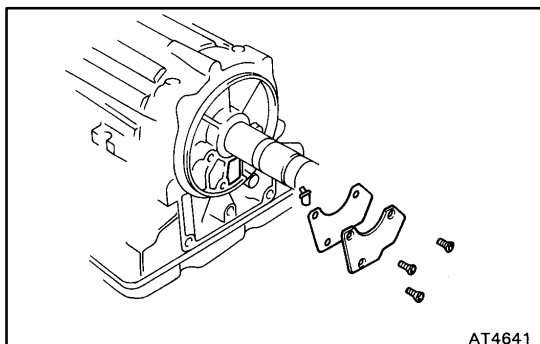

AT4641

29. INSTALL GOVERNOR OIL STRAINER

- (a) Insert the oil strainer into the transmission case.
 (b) Install a new gasket and cover.
 (c) Install and tighten the 3 screws.

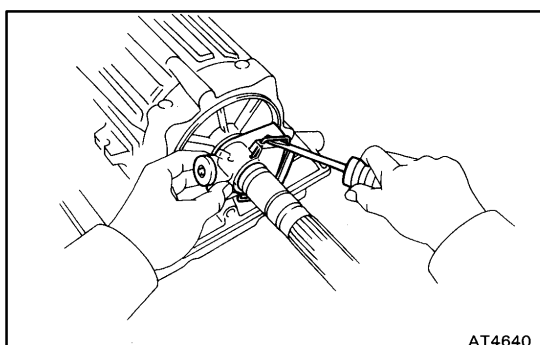

AT4640

30. INSTALL GOVERNOR BODY ON OUTPUT SHAFT

- (a) While lifting the retaining clip with a screwdriver, slide the governor body and insert the retaining clip end into the hole on the output shaft.

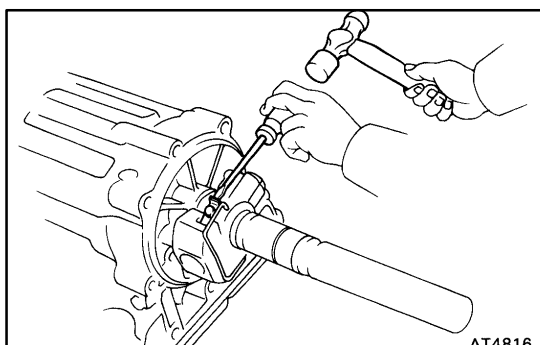

AT4816

- (b) Install a new lock plate and bolt, and tighten the bolt.
Torque: 3.9 N·m (40 kgf·cm, 35 in.-lbf)
 (c) Stake the lock plate.

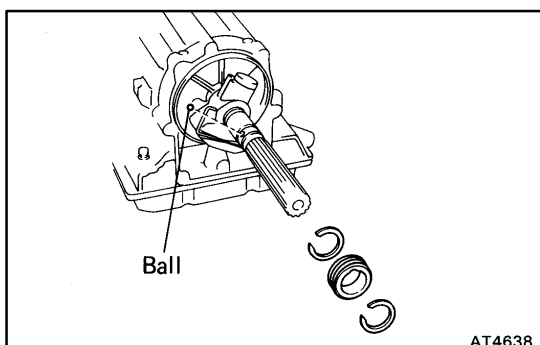

AT4638

31. INSTALL VEHICLE SPEED SENSOR DRIVE GEAR AND BALL

- (a) Using a snap ring expander, install the snap ring.
 (b) Install the ball into the hole on the output shaft.
 (c) Align the groove of the drive gear with the ball, install the drive gear.
 (d) Using a snap ring expander, install the snap ring.

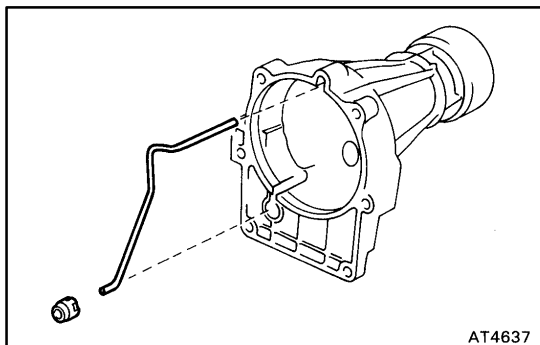

32. INSTALL EXTENSION HOUSING

- (a) Install the oil apply tube and a new gasket to the extension housing.

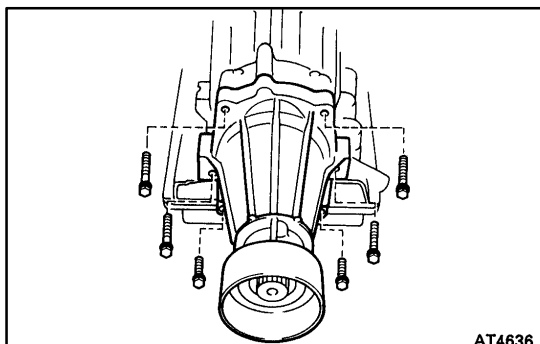

- (b) Install the extension housing with a new gasket to the case.
- (c) Apply sealant to the bolt A.

Sealant:

Part No. 08833-00080, THREE BOND 1344, LOCTITE 242 or equivalent

- (d) Install and tighten the 6 bolts.
HINT: The 2 lower bolts are shorter.
Torque: 34 N·m (345 kgf·cm, 25 ft·lbf)

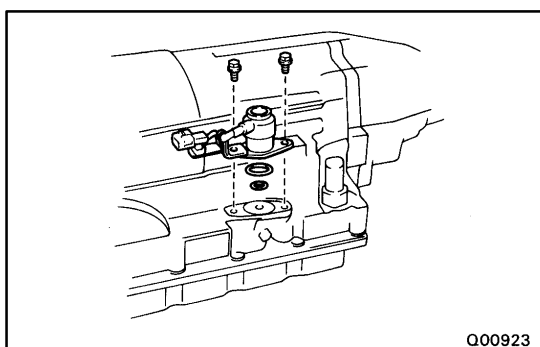

33. INSTALL OVERDRIVE SOLENOID

- (a) Coat 2 new O-rings with ATF and install them to the overdrive solenoid.
- (b) Install the overdrive solenoid with the 2 bolts.
- (c) Tighten the bolts.
Torque: 13 N·m (130 kgf·cm, 9 ft·lbf)

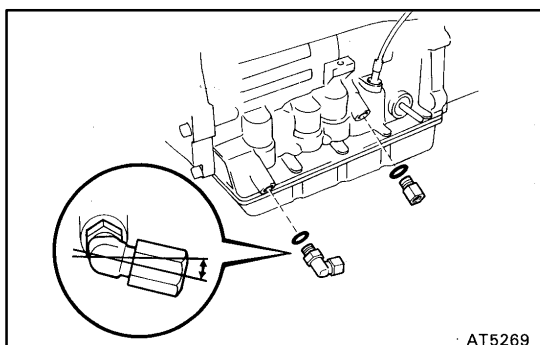

34. INSTALL UNIONS

- (a) Coat new 2 O-rings with ATF and install them to each unions.
- (b) Install and tighten the 2 unions.
Torque: 34 N·m (350 kgf·cm, 25 ft·lbf)

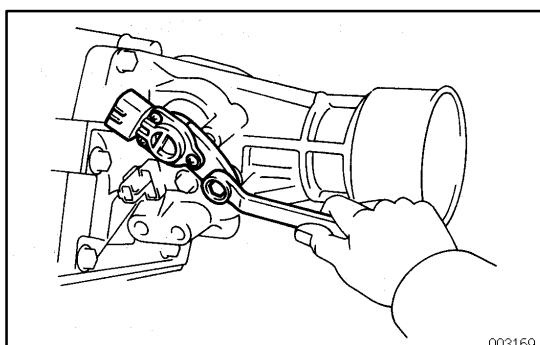

35. INSTALL NO.1 VEHICLE SPEED SENSOR

- (a) Coat a new O-ring with ATF and install it to the sleeve.
- (b) Install the No.1 vehicle speed sensor with the bolt.
- (c) Tighten the bolt.

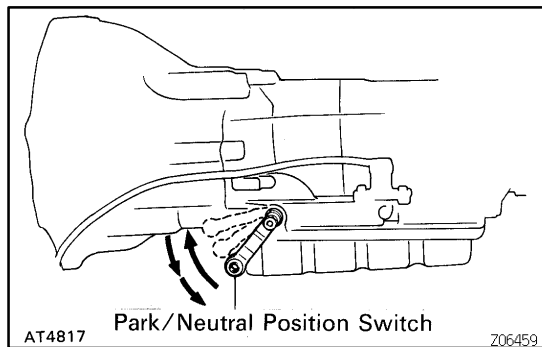

36. INSTALL PARK/NEUTRAL POSITION SWITCH

- (a) Using the control shaft lever, fully turn the manual valve lever shaft back and return 2 notches. It is now in neutral.

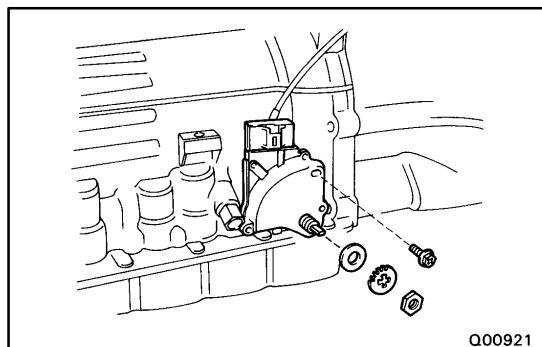

- (b) Insert the park/neutral position switch onto the manual valve lever shaft and temporarily tighten the adjusting bolt.

- (c) Install the grommet and a new lock washer. Install and tighten the nut.

Torque: 3.9 N·m (40 kgf·cm, 35 in.-lbf)

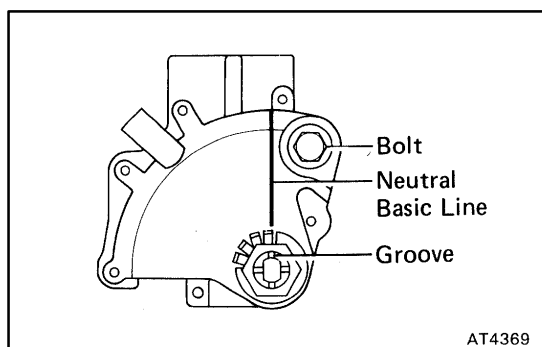

- (d) Align the neutral basic line and the switch groove, and tighten the adjusting bolt.

Torque: 5.4 N·m (55 kgf·cm, 48 in.-lbf)

- (e) Bend the tabs of the lock washer.

HINT: Bend at least 2 of the lock washer tabs.

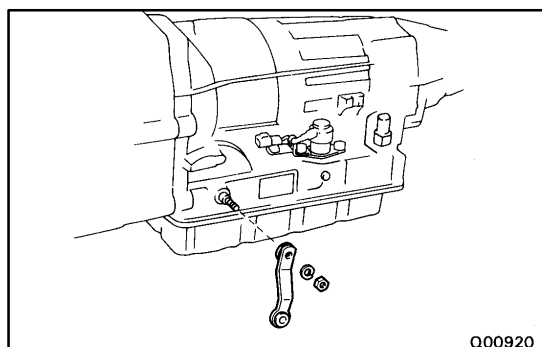

37. INSTALL CONTROL SHAFT LEVER

- (a) Install the control shaft lever with the spring washer and nut.

- (b) Tighten the nut.

Torque: 6.9 N·m (70 kgf·cm, 61 in.-lbf)

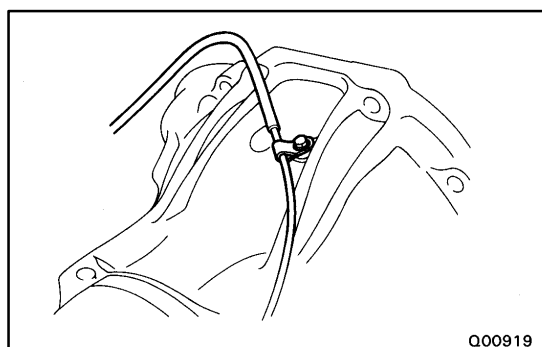

38. INSTALL WIRE HARNESS CLAMP AND THROTTLE CABLE CLAMP

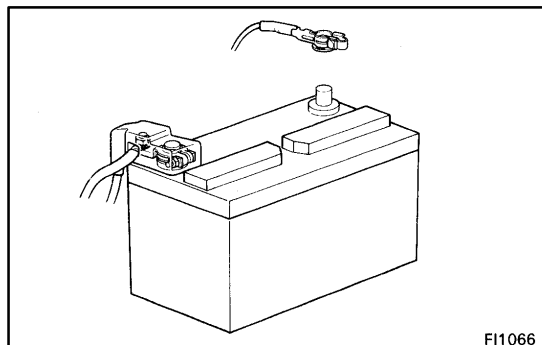

GENERAL REPAIR INSTRUCTIONS

1. Use fender, seat and floor covers to keep the vehicle clean and prevent damage.
2. During disassembly, keep parts in the appropriate order to facilitate reassembly.
3. Observe the following:
 - (a) Before performing electrical work, disconnect the negative (-) terminal cable from the battery.
 - (b) If it is necessary to disconnect the battery for inspection or repair, always disconnect the cable from the negative (-) terminal which is grounded to the vehicle body.
 - (c) To prevent damage to the battery terminal post, loosen the terminal nut and raise the cable straight up without twisting or prying it.
 - (d) Clean the battery terminal posts and cable terminals with a clean shop rag. Do not scrape them with a file or other abrasive objects.
 - (e) Install the cable terminal to the battery post with the nut loose, and tighten the nut after installation. Do not use a hammer to tap the terminal onto the post.
 - (f) Be sure the cover for the positive (+) terminal is properly in place.
4. Check hose and wiring connectors to make sure that they are secure and correct.
5. Non-reusable parts
 - (a) Always replace cotter pins, gaskets, O-rings and oil seals etc. with new ones.
 - (b) Non-reusable parts are indicated in the component illustrations by the "◆" symbol.

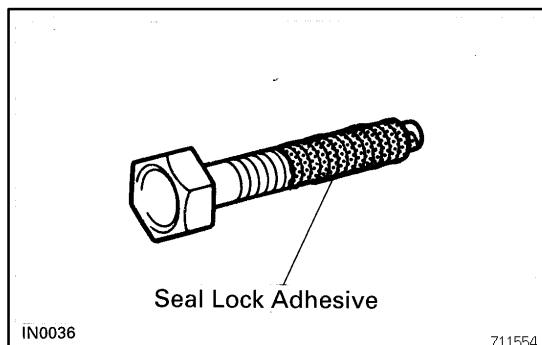

6. Precoated parts

Precoated parts are bolts and nuts, etc. that are coated with a seal lock adhesive at the factory.

 - (a) If a precoated part is retightened, loosened or caused to move in any way, it must be recoated with the specified adhesive.
 - (b) When reusing precoated parts, clean off the old adhesive and dry with compressed air. Then apply

the specified seal lock adhesive to the bolt, nut or threads.

(c) Precoated parts are indicated in the component illustrations by the "★" symbol.

7. When necessary, use a sealer on gaskets to prevent leaks.
8. Carefully observe all specifications for bolt tightening torques. Always use a torque wrench.
9. Use of special service tools (SST) and special service materials (SSM) may be required, depending on the nature of the repair. Be sure to use SST and SSM where specified and follow the proper work procedure. A list of SST and SSM can be found at the preparation of AT section.

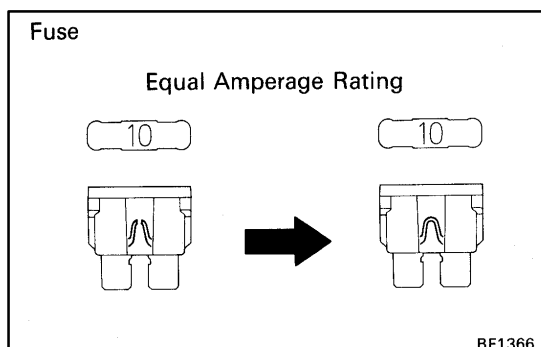

10. When replacing fuses, be sure the new fuse has the correct amperage rating. **DO NOT** exceed the rating or use one with a lower rating.

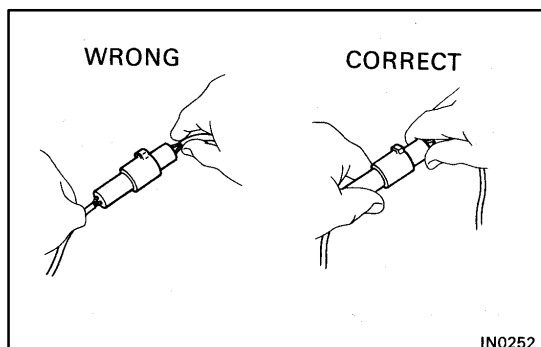

11. To pull apart electrical connectors, pull on the connector itself, not the wires.
12. Care must be taken when jacking up and supporting the vehicle. Be sure to lift and support the vehicle at the proper locations.
 - (a) If the vehicle is to be jacked up only at the front or rear end, be sure to block the wheels at the opposite end in order to ensure safety.
 - (b) After the vehicle is jacked up, be sure to support it on stands. It is extremely dangerous to do any work on a vehicle raised on a jack alone, even for a small job that can be finished quickly.

AT-14

AUTOMATIC TRANSMISSION - SERVICE SPECIFICATIONS

SERVICE SPECIFICATIONS

AT06P-0A

SERVICE DATE

Oil Pump

Body clearance	STD	0.07 - 0.15 mm	0.0028 - 0.0059 in.
	Maximum	0.3 mm	0.012 in.
Tip clearance	STD	0.11 - 0.14 mm	0.0043 - 0.0055 in.
	Maximum	0.3 mm	0.012 in.
Side clearance	STD	0.02 - 0.05 mm	0.0008 - 0.0020 in.
	Maximum	0.1 mm	0.004 in.
Pump body bushing inside diameter	Maximum	38.19 mm	1.5035 in.
Stator shaft bushing inside diameter			
Maximum	Front side	21.58 mm	0.8496 in.
Maximum	Rear side	21.58 mm	0.8496 in.

Overdrive Direct Clutch

Clutch drum bushing inside diameter	Maximum	23.14 mm	0.9110 in.
Overdrive direct clutch piston stroke		1.77 - 2.58 mm	0.0697 - 0.1016 in.
Overdrive planetary gear bushing	Maximum	11.27 mm	0.4437 in.
Planetary pinion gear thrust clearance	Standard	0.20 - 0.50 mm	0.0079 - 0.0197 in.

Overdrive Brake

Piston stroke		0.65 - 2.21 mm	0.0256 - 0.0870 in.
---------------	--	----------------	---------------------

Front Clutch

Piston stroke		1.32 - 2.66 mm	0.0520 - 0.1047 in.
Flange thickness		1.8 mm	0.071 in.
		2.0 mm	0.079 in.

Rear Clutch

Piston stroke		0.91 - 1.99 mm	0.0358 - 0.0783 in.
---------------	--	----------------	---------------------

No.1 Brake

Piston stroke		0.78 - 1.50 mm	0.0307 - 0.0591 in.
Center support bushing inside diameter	Maximum	36.46 mm	1.4354 in.

No.2 Brake

Piston stroke		1.01 - 2.25 mm	0.0398 - 0.0886 in.
---------------	--	----------------	---------------------

Planetary Sun Gear

Maximum inside diameter		21.58 mm	0.8496 in.
-------------------------	--	----------	------------

Front Planetary Gear

Planetary pinion gear thrust clearance		0.20 - 0.50 mm	0.0079 - 0.0197 in.
--	--	----------------	---------------------

Rear Planetary Gear

Planetary pinion gear thrust clearance	0.20 - 0.50 mm	0.0079 - 0.0197 in.
--	----------------	---------------------

No.3 Brake

Pack clearance	0.61 - 2.64 mm	0.0240 - 0.1039 in.
----------------	----------------	---------------------

Valve Body Spring

Spring	Free length and Coil outer diameter mm (in.)		Total No. of coils and Color	
Front upper valve body				
Secondary regulator valve	71.3 (2.807)	17.4 (0.685)	17.0	Green
Down shift plug	39.8 (1.567)	10.8 (0.425)	13.5	Purple
Throttle valve	21.9 (0.862)	8.6 (0.339)	10.0	None
Rear upper valve body				
2-3 shift valve	35.1 (1.382)	9.0 (0.354)	13.7	White
Detent regulator valve	29.1 (1.146)	8.9 (0.350)	15.0	Red
Intermediate modulator valve	27.3 (1.075)	9.0 (0.354)	11.5	Green
Reverse clutch sequence valve	37.6 (1.480)	9.2 (0.362)	16.5	None
Low coast modulator valve	42.4 (1.669)	9.2 (0.362)	17.0	None
Lower valve body				
Check ball (Cooler return)	13.7 (0.539)	10.5 (0.413)	10.0	None
Cooler by-pass valve	28.9 (1.138)	13.8 (0.543)	8.5	Orange
Check ball (Damping check ball)	20.0 (0.787)	5.0 (0.196)	18.0	None
1-2 shift valve	34.6 (1.362)	7.6 (0.299)	15.0	None
3-4 shift valve	33.7 (1.327)	10.6 (0.417)	16.5	Orange
Pressure relief valve	32.1 (1.264)	13.1 (0.516)	11.0	None
Primary regulator valve	55.2 (2.173)	17.0 (0.669)	12.5	White

Valve Body Key

Retainer	Height mm (in.)	Width mm (in.)	Thickness mm (in.)
Front upper valve body			
Cut-back valve	19.0 (0.748)	5.0 (0.197)	3.2 (0.126)
Rear upper valve body			
Detent regulator valve	21.2 (0.835)	5.0 (0.197)	3.2 (0.126)
2-3 shift valve	14.0 (0.551)	5.0 (0.197)	3.2 (0.126)
Intermediate shift valve	14.0 (0.551)	10.0 (0.394)	3.2 (0.126)
Lower valve body			
1 - 2 shift valve	19.0 (0.748)	5.0 (0.197)	3.2 (0.126)
Primary regulator valve	17.5 (0.689)	5.0 (0.197)	3.2 (0.126)

Transmission Case

Transmission case bushing	Maximum	38.19 mm	1.5035 in.
---------------------------	---------	----------	------------

Extension Housing

Extension housing bushing	Maximum	38.09 mm	1.4996 in.
---------------------------	---------	----------	------------

AT-16

AUTOMATIC TRANSMISSION - SERVICE SPECIFICATIONS

Output Shaft

End play	0.3 - 0.9 mm	0.012 - 0.035 in.
----------	--------------	-------------------

Accumulator Spring

Spring	Free length mm (in.)	Color
C ₁	64.7 (2.547)	None
C ₂	55.2 (2.173)	White
B ₂	66.7 (2.626)	Purple

AT06Q-0A







TORQUE SPECIFICATION

Part tightened	N·m	kgf·cm	ft·lbf
Stator shaft x Oil pump body	7.4	75	65 in.·lbf
Throttle cam x Front upper valve body	7.4	75	65 in.·lbf
Valve body cover x Front upper valve body	5.4	55	48 in.·lbf
Valve body cover x Rear upper valve body	5.4	55	48 in.·lbf
Valve body cover x Lower valve body	5.4	55	48 in.·lbf
Upper valve body x Lower valve body	5.4	55	48 in.·lbf
Lower valve body cover x Lower valve body	5.4	55	48 in.·lbf
Detent spring x Valve body	5.4	55	48 in.·lbf
Center support x Transmission case	25	260	19
Transmission housing x Transmission case			
	10 mm bolt	34	345
	12 mm bolt	57	580
Oil pump x Transmission case	21	215	16
Parking lock pawl bracket	7.4	75	65 in.·lbf
Valve body x Transmission case	10	100	7
Oil strainer x Valve body	5.4	55	48 in.·lbf
Oil pan x Transmission case	4.4	45	39 in.·lbf
Governor body lock plate	3.9	40	35 in.·lbf
Extension housing x Transmission case	34	345	25
Overdrive solenoid x Transmission case	13	130	9
Union	34	350	25
Park/Neutral position switch	5.4	55	48 in.·lbf
Park/Neutral position switch adjusting bolt	3.9	40	35 in.·lbf
Control shaft lever	6.9	70	61 in.·lbf

STANDARD BOLT TORQUE SPECIFICATIONS

HOW TO DETERMINE BOLT STRENGTH

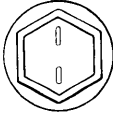
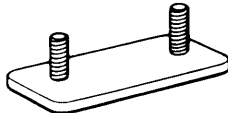
IN008-02

	Mark	Class		Mark	Class
Hexagon head bolt	4— 5— 6— Bolt head No. 7— 8— 9— 10— 11—	4T 5T 6T 7T 8T 9T 10T 11T	Stud bolt	 No mark	4T
	 No mark	4T			
Hexagon flange bolt w/ washer hexagon bolt	 No mark	4T	Welded bolt	 Grooved	6T
Hexagon head bolt	 2 protruding lines	5T			
Hexagon flange bolt w/ washer hexagon bolt	 2 protruding lines	6T	 4T		
Hexagon head bolt	 3 protruding lines	7T			
Hexagon head bolt	 4 protruding lines	8T			

SPECIFIED TORQUE FOR STANDARD BOLTS

Class	Diameter mm	Pitch mm	Specified torque					
			Hexagon head bolt			Hexagon flange bolt		
			N·m	kgf·cm	ft·lbf	N·m	kgf·cm	ft·lbf
4T	6	1	5	55	48 in.·lbf	6	60	52 in.·lbf
	8	1.25	12.5	130	9	14	145	10
	10	1.25	26	260	19	29	290	21
	12	1.25	47	480	35	53	540	39
	14	1.5	74	760	55	84	850	61
	16	1.5	115	1,150	83	—	—	—
5T	6	1	6.5	65	56 in.·lbf	7.5	75	65 in.·lbf
	8	1.25	15.5	160	12	17.5	175	13
	10	1.25	32	330	24	36	360	26
	12	1.25	59	600	43	65	670	48
	14	1.5	91	930	67	100	1,050	76
	16	1.5	140	1,400	101	—	—	—
6T	6	1	8	80	69 in.·lbf	9	90	78 in.·lbf
	8	1.25	19	195	14	21	210	15
	10	1.25	39	400	29	44	440	32
	12	1.25	71	730	53	80	810	59
	14	1.5	110	1,100	80	125	1,250	90
	16	1.5	170	1,750	127	—	—	—
7T	6	1	10.5	110	8	12	120	9
	8	1.25	25	260	19	28	290	21
	10	1.25	52	530	38	58	590	43
	12	1.25	95	970	70	105	1,050	76
	14	1.5	145	1,500	108	165	1,700	123
	16	1.5	230	2,300	166	—	—	—
8T	8	1.25	29	300	22	33	330	24
	10	1.25	61	620	45	68	690	50
	12	1.25	110	1,100	80	120	1,250	90
9T	8	1.25	34	340	25	37	380	27
	10	1.25	70	710	51	78	790	57
	12	1.25	125	1,300	94	140	1,450	105
10T	8	1.25	38	390	28	42	430	31
	10	1.25	78	800	58	88	890	64
	12	1.25	140	1,450	105	155	1,600	116
11T	8	1.25	42	430	31	47	480	35
	10	1.25	87	890	64	97	990	72
	12	1.25	155	1,600	116	175	1,800	130